



1 Mbit / 2 Mbit / 4 Mbit (x8) Multi-Purpose Flash

SST39LF010 / SST39LF020 / SST39LF040

SST39VF010 / SST39VF020 / SST39VF040

The SST39LF010, SST39LF020, SST39LF040 and SST39VF010, SST39VF020, SST39VF040 are 128K x8, 256K x8 and 512K x8 CMOS Multi-Purpose Flash (MPF) manufactured with SST's proprietary, high performance CMOS SuperFlash technology. The split-gate cell design and thick-oxide tunneling injector attain better reliability and manufacturability compared with alternate approaches. The SST39LF010/020/040 devices write (Program or Erase) with a 3.0-3.6V power supply. The SST39VF010/020/040 devices write with a 2.7-3.6V power supply. The devices conform to JEDEC standard pinouts for x8 memories.

Features

- **Organized as 128K x8 / 256K x8 / 512K x8**
- **Single Voltage Read and Write Operations**
 - 3.0-3.6V for SST39LF010/020/040
 - 2.7-3.6V for SST39VF010/020/040
- **Superior Reliability**
 - Endurance: 100,000 Cycles (typical)
 - Greater than 100 years Data Retention
- **Low Power Consumption (typical values at 14 MHz)**
 - Active Current: 5 mA (typical)
 - Standby Current: 1 μ A (typical)
- **Sector-Erase Capability**
 - Uniform 4 KByte sectors
- **Fast Read Access Time:**
 - 45 ns for SST39LF010/020/040
 - 55 ns for SST39LF020/040
 - 70 ns for SST39VF010/020/040
- **Latched Address and Data**
- **Fast Erase and Byte-Program:**
 - Sector-Erase Time: 18 ms (typical)
 - Chip-Erase Time: 70 ms (typical)
 - Byte-Program Time: 14 μ s (typical)
 - Chip Rewrite Time:
 - 2 seconds (typical) for SST39LF/VF010
 - 4 seconds (typical) for SST39LF/VF020
 - 8 seconds (typical) for SST39LF/VF040
- **Automatic Write Timing**
 - Internal V_{PP} Generation
- **End-of-Write Detection**
 - Toggle Bit
 - Data# Polling
- **CMOS I/O Compatibility**
- **JEDEC Standard**
 - Flash EEPROM Pinouts and command sets
- **Packages Available**
 - 32-lead PLCC
 - 32-lead TSOP (8mm x 14mm)
 - 48-ball TFBGA (6mm x 8mm)
 - 34-ball WFBGA (4mm x 6mm) for 1M and 2M
- **All devices are RoHS compliant**



1 Mbit / 2 Mbit / 4 Mbit Multi-Purpose Flash

SST39LF010 / SST39LF020 / SST39LF040

SST39VF010 / SST39VF020 / SST39VF040

Product Description

The SST39LF010, SST39LF020, SST39LF040 and SST39VF010, SST39VF020, SST39VF040 are 128K x8, 256K x8 and 512K x8 CMOS Multi-Purpose Flash (MPF) manufactured with SST's proprietary, high performance CMOS SuperFlash technology. The split-gate cell design and thick-oxide tunneling injector attain better reliability and manufacturability compared with alternate approaches. The SST39LF010/020/040 devices write (Program or Erase) with a 3.0-3.6V power supply. The SST39VF010/020/040 devices write with a 2.7-3.6V power supply. The devices conform to JEDEC standard pinouts for x8 memories.

Featuring high performance Byte-Program, the SST39LF010/020/040 and SST39VF010/020/040 devices provide a maximum Byte-Program time of 20 μ sec. These devices use Toggle Bit or Data# Polling to indicate the completion of Program operation. To protect against inadvertent write, they have on-chip hardware and Software Data Protection schemes. Designed, manufactured, and tested for a wide spectrum of applications, they are offered with a guaranteed typical endurance of 100,000 cycles. Data retention is rated at greater than 100 years.

The SST39LF010/020/040 and SST39VF010/020/040 devices are suited for applications that require convenient and economical updating of program, configuration, or data memory. For all system applications, they significantly improve performance and reliability, while lowering power consumption. They inherently use less energy during Erase and Program than alternative flash technologies. The total energy consumed is a function of the applied voltage, current, and time of application. Since for any given voltage range, the SuperFlash technology uses less current to program and has a shorter erase time, the total energy consumed during any Erase or Program operation is less than alternative flash technologies. These devices also improve flexibility while lowering the cost for program, data, and configuration storage applications.

The SuperFlash technology provides fixed Erase and Program times, independent of the number of Erase/Program cycles that have occurred. Therefore the system software or hardware does not have to be modified or de-rated as is necessary with alternative flash technologies, whose Erase and Program times increase with accumulated Erase/Program cycles.

To meet surface mount requirements, the SST39LF010/020/040 and SST39VF010/020/040 devices are offered in 32-lead PLCC and 32-lead TSOP packages. The SST39LF/VF010 and SST39LF/VF020 are also offered in a 48-ball TFBGA package. See Figures 2, 3, 4, and 5 for pin assignments.



Block Diagram

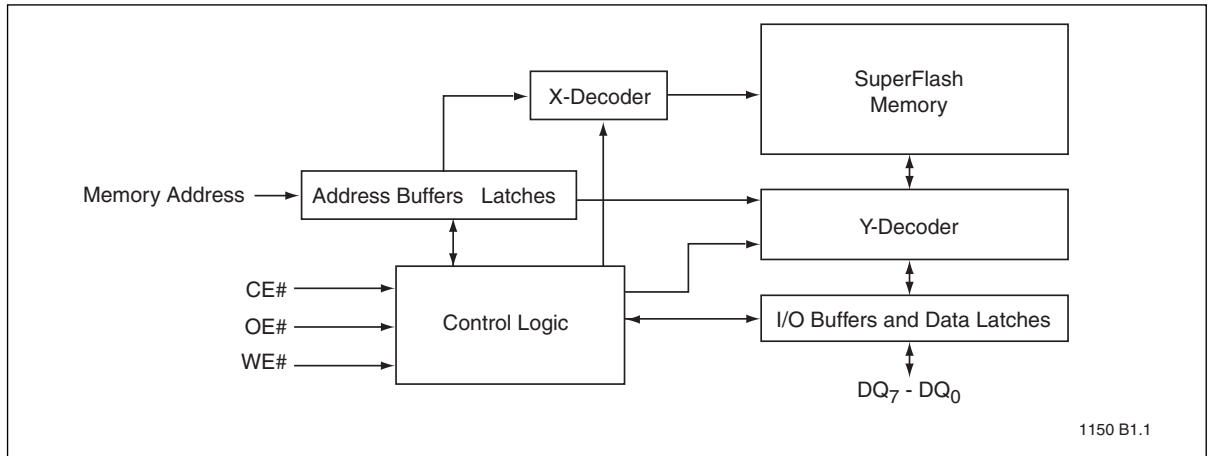

Figure 1: Functional Block Diagram



1 Mbit / 2 Mbit / 4 Mbit Multi-Purpose Flash

SST39LF010 / SST39LF020 / SST39LF040

SST39VF010 / SST39VF020 / SST39VF040

Pin Assignments

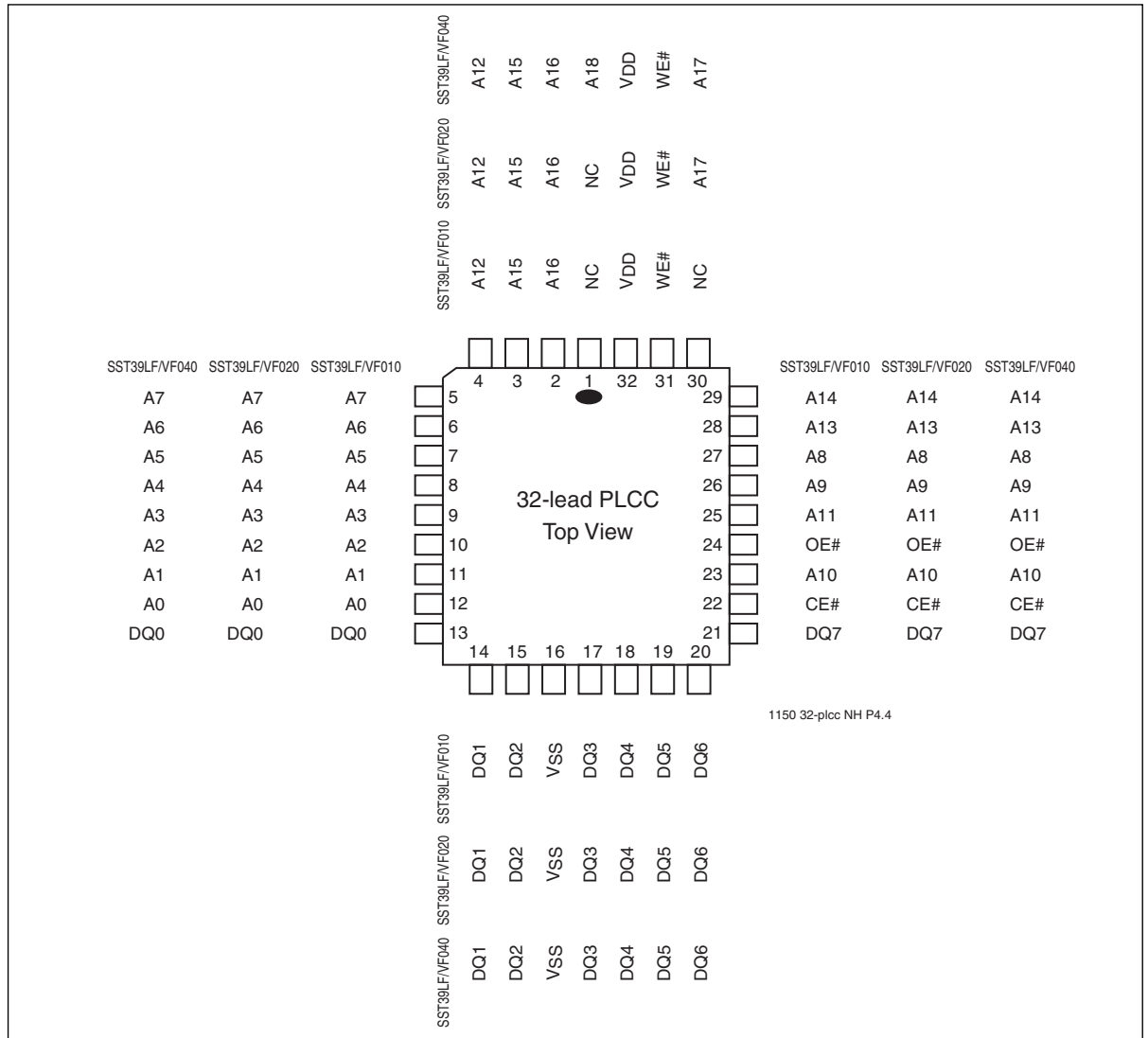

Figure 2: Pin Assignments for 32-lead PLCC



1 Mbit / 2 Mbit / 4 Mbit Multi-Purpose Flash

SST39LF010 / SST39LF020 / SST39LF040

SST39VF010 / SST39VF020 / SST39VF040

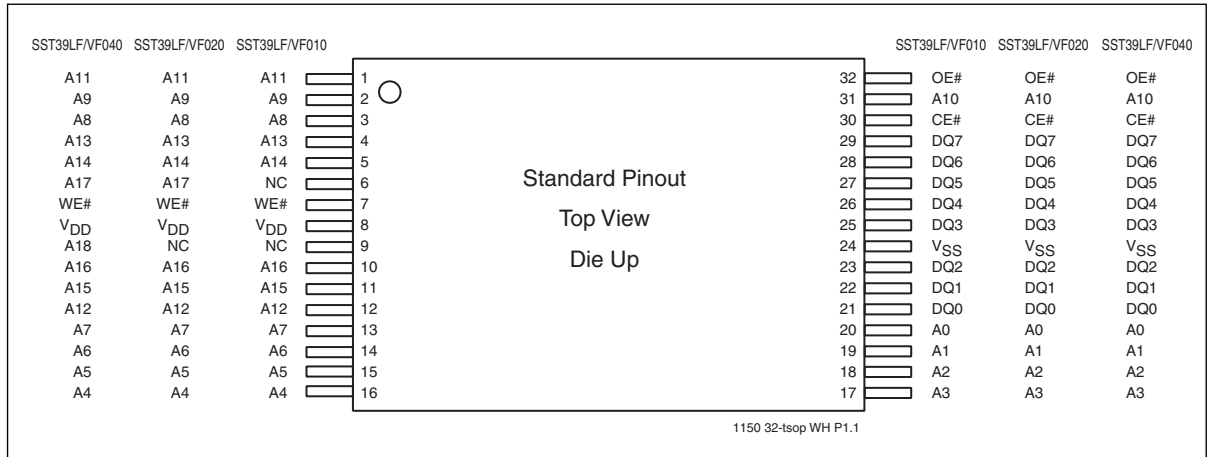

Figure 3: Pin Assignments for 32-lead TSOP (8mm x 14mm)

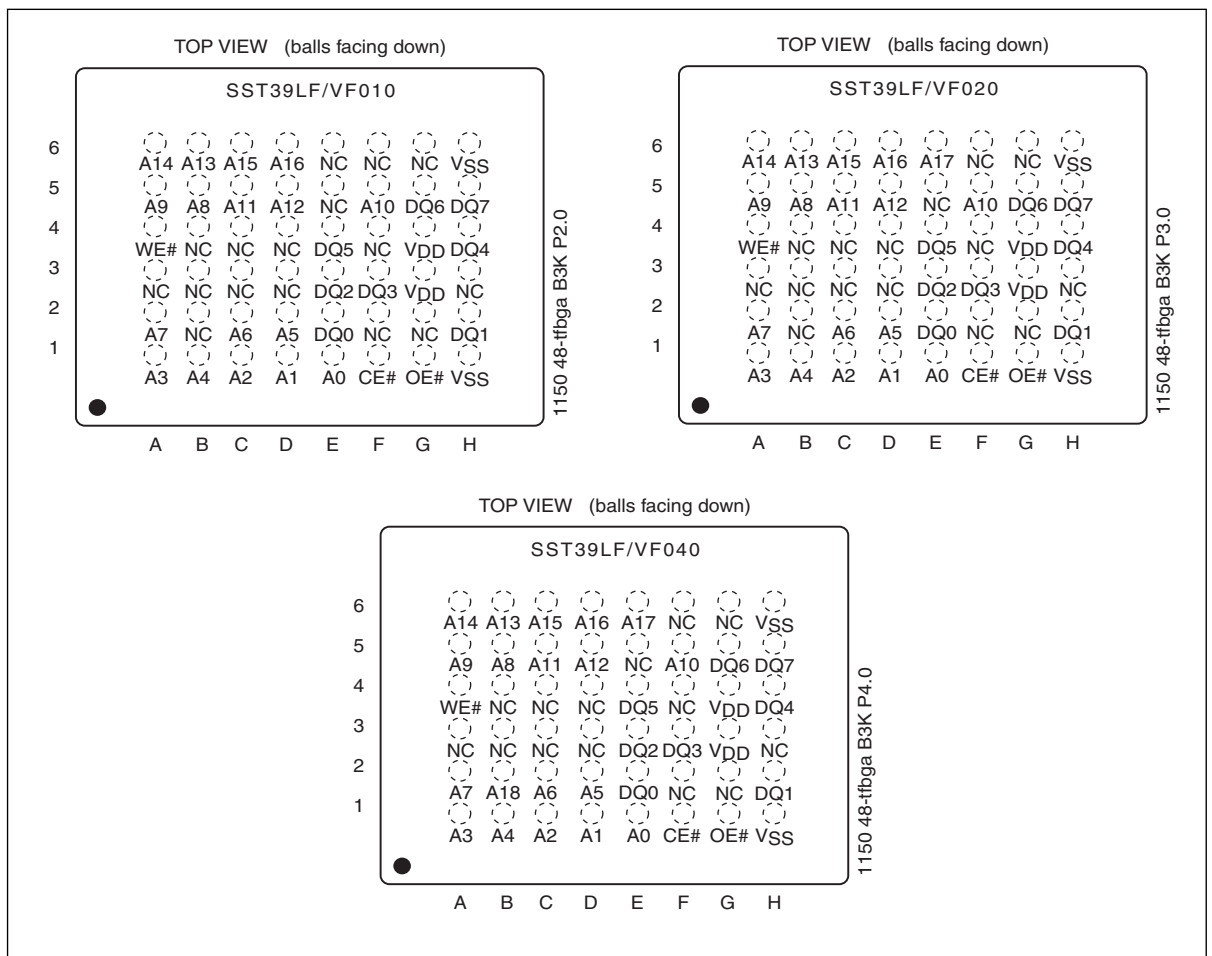

Figure 4: Pin Assignment for 48-ball TFBGA (6mm x 8mm) for 1 Mbit, 2 Mbit, and 4 Mbit



1 Mbit / 2 Mbit / 4 Mbit Multi-Purpose Flash

SST39LF010 / SST39LF020 / SST39LF040

SST39VF010 / SST39VF020 / SST39VF040

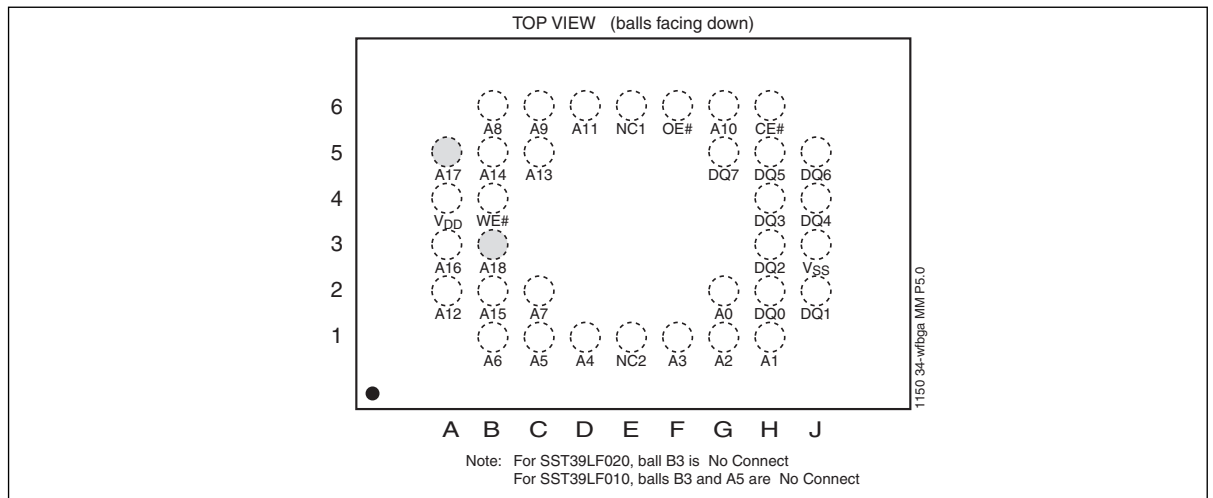

Figure 5: Pin Assignment for 34-ball WFBGA (4mm x 6mm) for 1 Mbit and 2 Mbit

Table 1: Pin Description

Symbol	Pin Name	Functions
$A_{MS}^1-A_0$	Address Inputs	To provide memory addresses. During Sector-Erase $A_{MS}-A_{12}$ address lines will select the sector. During Block-Erase $A_{MS}-A_{16}$ address lines will select the block.
DQ_7-DQ_0	Data Input/output	To output data during Read cycles and receive input data during Write cycles. Data is internally latched during a Write cycle. The outputs are in tri-state when OE# or CE# is high.
CE#	Chip Enable	To activate the device when CE# is low.
OE#	Output Enable	To gate the data output buffers.
WE#	Write Enable	To control the Write operations.
V_{DD}	Power Supply	To provide power supply voltage: 3.0-3.6V for SST39LF010/020/040 2.7-3.6V for SST39VF010/020/040
V_{SS}	Ground	
NC	No Connection	Unconnected pins.

T1.1 25023

- A_{MS} = Most significant address
 A_{MS} = A_{16} for SST39LF/VF010, A_{17} for SST39LF/VF020, and A_{18} for SST39LF/VF040



Device Operation

Commands are used to initiate the memory operation functions of the device. Commands are written to the device using standard microprocessor write sequences. A command is written by asserting WE# low while keeping CE# low. The address bus is latched on the falling edge of WE# or CE#, whichever occurs last. The data bus is latched on the rising edge of WE# or CE#, whichever occurs first.

Read

The Read operation of the SST39LF010/020/040 and SST39VF010/020/040 devices are controlled by CE# and OE#, both have to be low for the system to obtain data from the outputs. CE# is used for device selection. When CE# is high, the chip is deselected and only standby power is consumed. OE# is the output control and is used to gate data from the output pins. The data bus is in high impedance state when either CE# or OE# is high. Refer to the Read cycle timing diagram for further details (Figure 6).

Byte-Program Operation

The SST39LF010/020/040 and SST39VF010/020/040 are programmed on a byte-by-byte basis. Before programming, the sector where the byte exists must be fully erased. The Program operation is accomplished in three steps. The first step is the three-byte load sequence for Software Data Protection. The second step is to load byte address and byte data. During the Byte-Program operation, the addresses are latched on the falling edge of either CE# or WE#, whichever occurs last. The data is latched on the rising edge of either CE# or WE#, whichever occurs first. The third step is the internal Program operation which is initiated after the rising edge of the fourth WE# or CE#, whichever occurs first. The Program operation, once initiated, will be completed, within 20 μ s. See Figures 7 and 8 for WE# and CE# controlled Program operation timing diagrams and Figure 17 for flowcharts. During the Program operation, the only valid reads are Data# Polling and Toggle Bit. During the internal Program operation, the host is free to perform additional tasks. Any commands written during the internal Program operation will be ignored.

Sector-Erase Operation

The Sector-Erase operation allows the system to erase the device on a sector-by-sector basis. The sector architecture is based on uniform sector size of 4 KByte. The Sector-Erase operation is initiated by executing a six-byte command sequence with Sector-Erase command (30H) and sector address (SA) in the last bus cycle. The sector address is latched on the falling edge of the sixth WE# pulse, while the command (30H) is latched on the rising edge of the sixth WE# pulse. The internal Erase operation begins after the sixth WE# pulse. The End-of-Erase can be determined using either Data# Polling or Toggle Bit methods. See Figure 11 for timing waveforms. Any commands written during the Sector-Erase operation will be ignored.

Chip-Erase Operation

The SST39LF010/020/040 and SST39VF010/020/040 devices provide a Chip-Erase operation, which allows the user to erase the entire memory array to the '1's state. This is useful when the entire device must be quickly erased.

The Chip-Erase operation is initiated by executing a six-byte Software Data Protection command sequence with Chip-Erase command (10H) with address 5555H in the last byte sequence. The internal Erase operation begins with the rising edge of the sixth WE# or CE#, whichever occurs first. During the



1 Mbit / 2 Mbit / 4 Mbit Multi-Purpose Flash

SST39LF010 / SST39LF020 / SST39LF040

SST39VF010 / SST39VF020 / SST39VF040

Data Sheet

internal Erase operation, the only valid read is Toggle Bit or Data# Polling. See Table 4 for the command sequence, Figure 12 for timing diagram, and Figure 20 for the flowchart. Any commands written during the Chip-Erase operation will be ignored.

Write Operation Status Detection

The SST39LF010/020/040 and SST39VF010/020/040 devices provide two software means to detect the completion of a Write (Program or Erase) cycle, in order to optimize the system write cycle time. The software detection includes two status bits: Data# Polling (DQ₇) and Toggle Bit (DQ₆). The End-of-Write detection mode is enabled after the rising edge of WE# which initiates the internal Program or Erase operation.

The actual completion of the nonvolatile write is asynchronous with the system; therefore, either a Data# Polling or Toggle Bit read may be simultaneous with the completion of the Write cycle. If this occurs, the system may possibly get an erroneous result, i.e., valid data may appear to conflict with either DQ₇ or DQ₆. In order to prevent spurious rejection, if an erroneous result occurs, the software routine should include a loop to read the accessed location an additional two (2) times. If both reads are valid, then the device has completed the Write cycle, otherwise the rejection is valid.



1 Mbit / 2 Mbit / 4 Mbit Multi-Purpose Flash

SST39LF010 / SST39LF020 / SST39LF040

SST39VF010 / SST39VF020 / SST39VF040

Data# Polling (DQ₇)

When the SST39LF010/020/040 and SST39VF010/020/040 are in the internal Program operation, any attempt to read DQ₇ will produce the complement of the true data. Once the Program operation is completed, DQ₇ will produce true data. Note that even though DQ₇ may have valid data immediately following completion of an internal Write operation, the remaining data outputs may still be invalid: valid data on the entire data bus will appear in subsequent successive Read cycles after an interval of 1 μ s. During internal Erase operation, any attempt to read DQ₇ will produce a "0". Once the internal Erase operation is completed, DQ₇ will produce a "1". The Data# Polling is valid after the rising edge of fourth WE# (or CE#) pulse for Program operation. For Sector- or Chip-Erase, the Data# Polling is valid after the rising edge of sixth WE# (or CE#) pulse. See Figure 9 for Data# Polling timing diagram and Figure 18 for a flowchart.

Toggle Bit (DQ₆)

During the internal Program or Erase operation, any consecutive attempts to read DQ₆ will produce alternating '0's and '1's, i.e., toggling between 0 and 1. When the internal Program or Erase operation is completed, the toggling will stop. The device is then ready for the next operation. The Toggle Bit is valid after the rising edge of fourth WE# (or CE#) pulse for Program operation. For Sector- or Chip-Erase, the Toggle Bit is valid after the rising edge of sixth WE# (or CE#) pulse. See Figure 10 for Toggle Bit timing diagram and Figure 18 for a flowchart.

Data Protection

The SST39LF010/020/040 and SST39VF010/020/040 provide both hardware and software features to protect nonvolatile data from inadvertent writes.

Hardware Data Protection

Noise/Glitch Protection: A WE# or CE# pulse of less than 5 ns will not initiate a Write cycle.

V_{DD} Power Up/Down Detection: The Write operation is inhibited when V_{DD} is less than 1.5V.

Write Inhibit Mode: Forcing OE# low, CE# high, or WE# high will inhibit the Write operation. This prevents inadvertent writes during power-up or power-down.



1 Mbit / 2 Mbit / 4 Mbit Multi-Purpose Flash

SST39LF010 / SST39LF020 / SST39LF040

SST39VF010 / SST39VF020 / SST39VF040

Software Data Protection (SDP)

The SST39LF010/020/040 and SST39VF010/020/040 provide the JEDEC approved Software Data Protection scheme for all data alteration operation, i.e., Program and Erase. Any Program operation requires the inclusion of a series of three-byte sequence. The three-byte load sequence is used to initiate the Program operation, providing optimal protection from inadvertent Write operations, e.g., during the system power-up or power-down. Any Erase operation requires the inclusion of six-byte load sequence. These devices are shipped with the Software Data Protection permanently enabled. See Table 4 for the specific software command codes. During SDP command sequence, invalid commands will abort the device to read mode, within T_{RC} .

Product Identification

The Product Identification mode identifies the devices as the SST39LF/VF010, SST39LF/VF020, and SST39LF/VF040 and manufacturer as SST. This mode may be accessed by software operations. Users may use the Software Product Identification operation to identify the part (i.e., using the device ID) when using multiple manufacturers in the same socket. For details, see Table 4 for software operation, Figure 13 for the Software ID Entry and Read timing diagram, and Figure 19 for the Software ID entry command sequence flowchart.

Table 2: Product Identification

	Address	Data
Manufacturer's ID	0000H	BFH
Device ID		
SST39LF/VF010	0001H	D5H
SST39LF/VF020	0001H	D6H
SST39LF/VF040	0001H	D7H

T2.1 25023

Product Identification Mode Exit/Reset

In order to return to the standard Read mode, the Software Product Identification mode must be exited. Exit is accomplished by issuing the Software ID Exit command sequence, which returns the device to the Read operation. Please note that the Software ID Exit command is ignored during an internal Program or Erase operation. See Table 4 for software command codes, Figure 14 for timing waveform, and Figure 19 for a flowchart.



Operations

Table 3: Operation Modes Selection

Mode	CE#	OE#	WE#	DQ	Address
Read	V _{IL}	V _{IL}	V _{IH}	D _{OUT}	A _{IN}
Program	V _{IL}	V _{IH}	V _{IL}	D _{IN}	A _{IN}
Erase	V _{IL}	V _{IH}	V _{IL}	X ¹	Sector address, XXH for Chip-Erase
Standby	V _{IH}	X	X	High Z	X
Write Inhibit	X	V _{IL}	X	High Z/ D _{OUT}	X
	X	X	V _{IH}	High Z/ D _{OUT}	X
Product Identification					
Software Mode	V _{IL}	V _{IL}	V _{IH}		See Table 4

T3.4 25023

1. X can be V_{IL} or V_{IH}, but no other value.

Table 4: Software Command Sequence

Command Sequence	1st Bus Write Cycle		2nd Bus Write Cycle		3rd Bus Write Cycle		4th Bus Write Cycle		5th Bus Write Cycle		6th Bus Write Cycle	
	Addr ¹	Data	Addr ¹	Data	Addr ¹	Data	Addr ¹	Data	Addr ¹	Data	Addr ¹	Data
Byte-Program	5555H	AAH	2AAAH	55H	5555H	A0H	BA ²	Data				
Sector-Erase	5555H	AAH	2AAAH	55H	5555H	80H	5555H	AAH	2AAAH	55H	SA _X ³	30H
Chip-Erase	5555H	AAH	2AAAH	55H	5555H	80H	5555H	AAH	2AAAH	55H	5555H	10H
Software ID Entry ^{4,5}	5555H	AAH	2AAAH	55H	5555H	90H						
Software ID Exit ⁶	XXH	F0H										
Software ID Exit ⁶	5555H	AAH	2AAAH	55H	5555H	F0H						

T4.2 25023

1. Address format A₁₄-A₀ (Hex),
Addresses A_{MS}-A₁₅ can be V_{IL} or V_{IH}, but no other value, for the Command sequence.
A_{MS} = Most significant address
A_{MS} = A₁₆ for SST39LF/VF010, A₁₇ for SST39LF/VF020, and A₁₈ for SST39LF/VF040
2. BA = Program Byte address
3. SA_X for Sector-Erase; uses A_{MS}-A₁₂ address lines
4. The device does not remain in Software Product ID mode if powered down.
5. With A_{MS}-A₁ = 0; SST Manufacturer's ID = BFH, is read with A₀ = 0,
SST39LF/VF010 Device ID = D5H, is read with A₀ = 1,
SST39LF/VF020 Device ID = D6H, is read with A₀ = 1,
SST39LF/VF040 Device ID = D7H, is read with A₀ = 1.
6. Both Software ID Exit operations are equivalent



1 Mbit / 2 Mbit / 4 Mbit Multi-Purpose Flash

SST39LF010 / SST39LF020 / SST39LF040

SST39VF010 / SST39VF020 / SST39VF040

Data Sheet

Absolute Maximum Stress Ratings (Applied conditions greater than those listed under “Absolute Maximum Stress Ratings” may cause permanent damage to the device. This is a stress rating only and functional operation of the device at these conditions or conditions greater than those defined in the operational sections of this data sheet is not implied. Exposure to absolute maximum stress rating conditions may affect device reliability.)

Temperature Under Bias	-55°C to +125°C
Storage Temperature	-65°C to +150°C
D. C. Voltage on Any Pin to Ground Potential	-0.5V to $V_{DD}+0.5V$
Transient Voltage (<20 ns) on Any Pin to Ground Potential	-2.0V to $V_{DD}+2.0V$
Voltage on A ₉ Pin to Ground Potential	-0.5V to 13.2V
Package Power Dissipation Capability (Ta = 25°C)	1.0W
Surface Mount Solder Reflow Temperature ¹	260°C for 10 seconds
Output Short Circuit Current ²	50 mA

1. Excluding certain with-Pb 32-PLCC units, all packages are 260°C capable in both non-Pb and with-Pb solder versions. Certain with-Pb 32-PLCC package types are capable of 240°C for 10 seconds; please consult the factory for the latest information.
2. Outputs shorted for no more than one second. No more than one output shorted at a time.

Table 5: Operating Range SST39LF010/020/040

Range	Ambient Temp	V _{DD}
Commercial	0°C to +70°C	3.0-3.6V

T5.1 25023

Table 6: Operating Range SST39VF010/020/040

Range	Ambient Temp	V _{DD}
Commercial	0°C to +70°C	2.7-3.6V
Industrial	-40°C to +85°C	2.7-3.6V

T6.1 25023

Table 7: AC Conditions of Test¹

Input Rise/Fall Time	Output Load
5ns	C _L = 30 pF for SST39LF010/020/040
	C _L = 100 pF for SST39VF010/020/040

T7.1 25023

1. See Figures 15 and 16



1 Mbit / 2 Mbit / 4 Mbit Multi-Purpose Flash

SST39LF010 / SST39LF020 / SST39LF040

SST39VF010 / SST39VF020 / SST39VF040

Data Sheet

Table 8: DC Operating Characteristics - $V_{DD} = 3.0\text{-}3.6\text{V}$ for SST39LF010/020/040 and $2.7\text{-}3.6\text{V}$ for SST39VF010/020/040¹

Symbol	Parameter	Limits			Test Conditions
		Min	Max	Units	
I _{DD}	Power Supply Current				Address input= V_{ILT}/V_{IHT} , at $f=1/T_{RC}$ Min $V_{DD}=V_{DD}$ Max
	Read ²		20	mA	$CE\#=V_{IL}$, $OE\#=WE\#=V_{IH}$, all I/Os open
	Program and Erase ³		30	mA	$CE\#=WE\#=V_{IL}$, $OE\#=V_{IH}$
I _{SB}	Standby V_{DD} Current		15	μA	$CE\#=V_{IHC}$, $V_{DD}=V_{DD}$ Max
I _{LI}	Input Leakage Current		1	μA	$V_{IN}=\text{GND to } V_{DD}$, $V_{DD}=V_{DD}$ Max
I _{LO}	Output Leakage Current		10	μA	$V_{OUT}=\text{GND to } V_{DD}$, $V_{DD}=V_{DD}$ Max
V _{IL}	Input Low Voltage		0.8	V	$V_{DD}=V_{DD}$ Min
V _{IH}	Input High Voltage	0.7V _{DD}		V	$V_{DD}=V_{DD}$ Max
V _{IHC}	Input High Voltage (CMOS)	V _{DD} -0.3		V	$V_{DD}=V_{DD}$ Max
V _{OL}	Output Low Voltage		0.2	V	$I_{OL}=100 \mu\text{A}$, $V_{DD}=V_{DD}$ Min
V _{OH}	Output High Voltage	V _{DD} -0.2		V	$I_{OH}=-100 \mu\text{A}$, $V_{DD}=V_{DD}$ Min

T8.7 25023

1. Typical conditions for the Active Current shown on the front data sheet page are average values at 25°C (room temperature), and $V_{DD} = 3\text{V}$ for VF devices. Not 100% tested.
2. Values are for 70 ns conditions. See the **Multi-Purpose Flash Power Rating** application note for further information.
3. 30 mA max for Erase operations in the industrial temperature range.

Table 9: Recommended System Power-up Timings

Symbol	Parameter	Minimum	Units
T _{PU-READ} ¹	Power-up to Read Operation	100	μs
T _{PU-WRITE} ¹	Power-up to Program/Erase Operation	100	μs

T9.1 25023

1. This parameter is measured only for initial qualification and after a design or process change that could affect this parameter.

Table 10: Capacitance ($T_a = 25^\circ\text{C}$, $f=1$ Mhz, other pins open)

Parameter	Description	Test Condition	Maximum
C _{I/O} ¹	I/O Pin Capacitance	$V_{I/O} = 0\text{V}$	12 pF
C _{IN} ¹	Input Capacitance	$V_{IN} = 0\text{V}$	6 pF

T10.0 25023

1. This parameter is measured only for initial qualification and after a design or process change that could affect this parameter.

Table 11: Reliability Characteristics

Symbol	Parameter	Minimum Specification	Units	Test Method
N _{END} ^{1,2}	Endurance	10,000	Cycles	JEDEC Standard A117
T _{DR} ¹	Data Retention	100	Years	JEDEC Standard A103
I _{LTH} ¹	Latch Up	100 + I _{DD}	mA	JEDEC Standard 78

T11.3 25023

1. This parameter is measured only for initial qualification and after a design or process change that could affect this parameter.
2. N_{END} endurance rating is qualified as a 10,000 cycle minimum for the whole device. A sector- or block-level rating would result in a higher minimum specification.



1 Mbit / 2 Mbit / 4 Mbit Multi-Purpose Flash

SST39LF010 / SST39LF020 / SST39LF040

SST39VF010 / SST39VF020 / SST39VF040

AC Characteristics

Table 12: Read Cycle Timing Parameters - $V_{DD} = 3.0\text{-}3.6\text{V}$ for SST39LF010/020/040 and $2.7\text{-}3.6\text{V}$ for SST39VF010/020/040

Symbol	Parameter	SST39LF010-45 SST39LF020-45 SST39LF040-45		SST39LF020-55 SST39LF040-55		SST39VF010-70 SST39VF020-70 SST39VF040-70		Units
		Min	Max	Min	Max	Min	Max	
T_{RC}	Read Cycle Time	45		55		70		ns
T_{CE}	Chip Enable Access Time		45		55		70	ns
T_{AA}	Address Access Time		45		55		70	ns
T_{OE}	Output Enable Access Time		30		30		35	ns
T_{CLZ}^1	CE# Low to Active Output	0		0		0		ns
T_{OLZ}^1	OE# Low to Active Output	0		0		0		ns
T_{CHZ}^1	CE# High to High-Z Output		15		15		25	ns
T_{OHZ}^1	OE# High to High-Z Output		15		15		25	ns
T_{OH}^1	Output Hold from Address Change	0		0		0		ns

T12.2 25023

1. This parameter is measured only for initial qualification and after a design or process change that could affect this parameter.

Table 13: Program/Erase Cycle Timing Parameters

Symbol	Parameter	Min	Max	Units
T_{BP}	Byte-Program Time		20	μs
T_{AS}	Address Setup Time	0		ns
T_{AH}	Address Hold Time	30		ns
T_{CS}	WE# and CE# Setup Time	0		ns
T_{CH}	WE# and CE# Hold Time	0		ns
T_{OES}	OE# High Setup Time	0		ns
T_{OEH}	OE# High Hold Time	10		ns
T_{CP}	CE# Pulse Width	40		ns
T_{WP}	WE# Pulse Width	40		ns
T_{WPH}^1	WE# Pulse Width High	30		ns
T_{CPH}^1	CE# Pulse Width High	30		ns
T_{DS}	Data Setup Time	40		ns
T_{DH}^1	Data Hold Time	0		ns
T_{IDA}^1	Software ID Access and Exit Time		150	ns
T_{SE}	Sector-Erase		25	ms
T_{SCE}	Chip-Erase		100	ms

T13.1 25023

1. This parameter is measured only for initial qualification and after a design or process change that could affect this parameter.



1 Mbit / 2 Mbit / 4 Mbit Multi-Purpose Flash

SST39LF010 / SST39LF020 / SST39LF040

SST39VF010 / SST39VF020 / SST39VF040

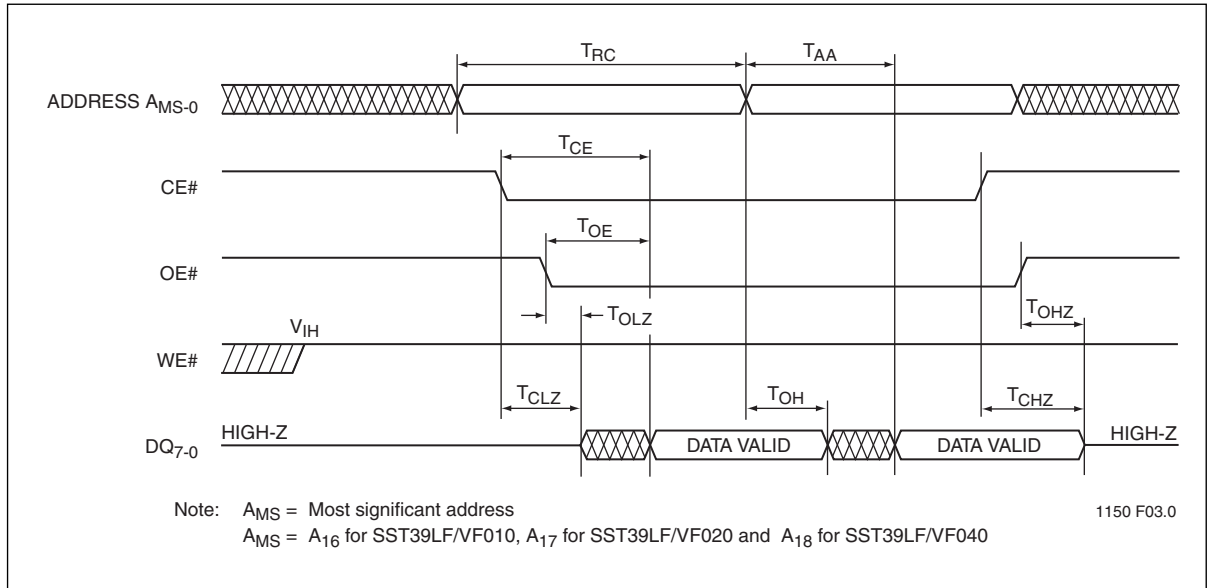

Figure 6: Read Cycle Timing Diagram

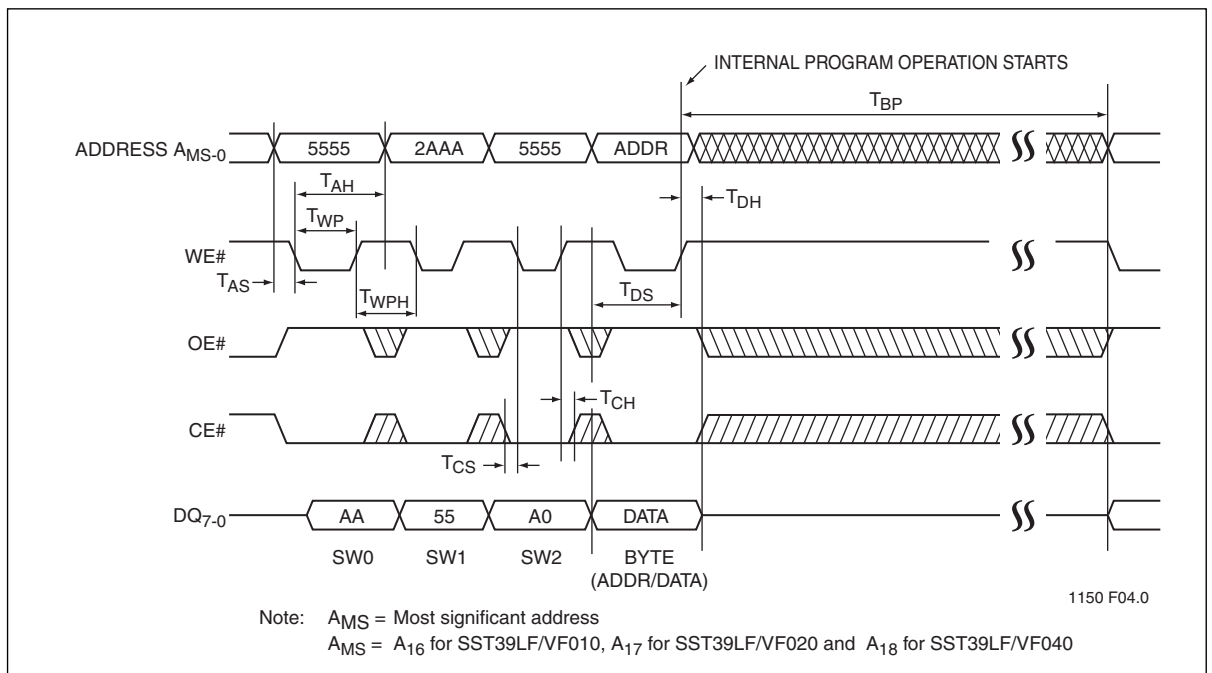

Figure 7: WE# Controlled Program Cycle Timing Diagram



1 Mbit / 2 Mbit / 4 Mbit Multi-Purpose Flash

SST39LF010 / SST39LF020 / SST39LF040

SST39VF010 / SST39VF020 / SST39VF040

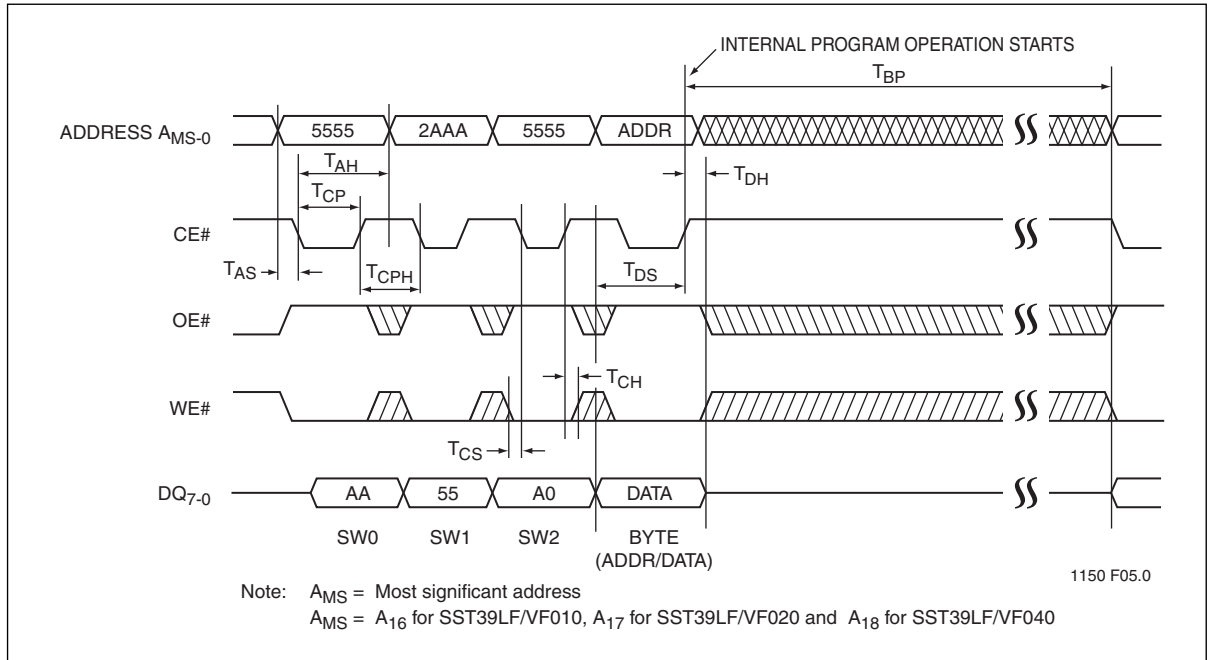

Figure 8: CE# Controlled Program Cycle Timing Diagram

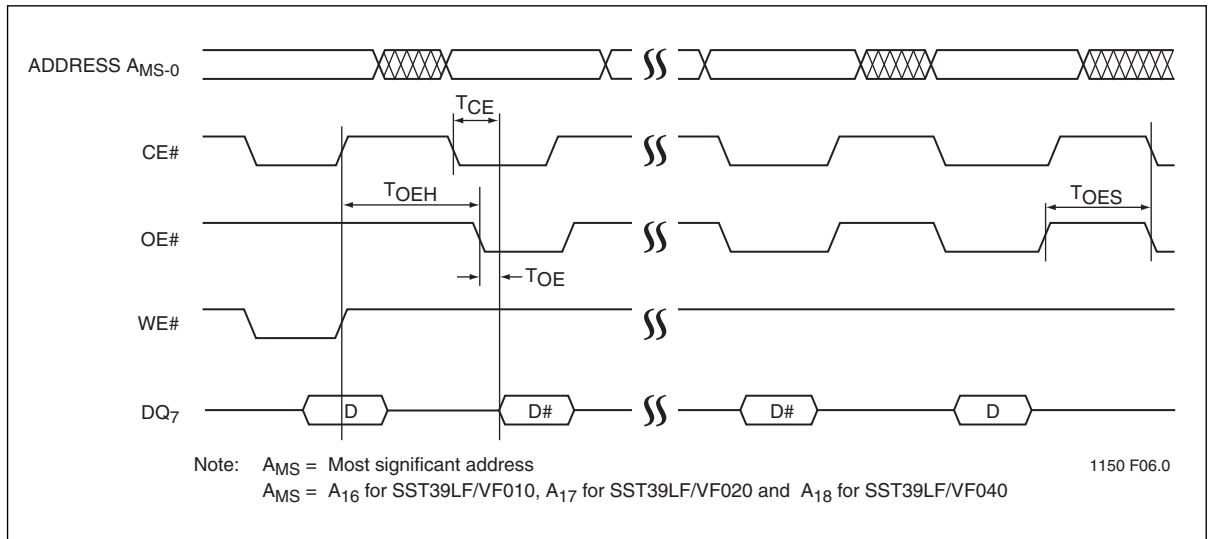

Figure 9: Data# Polling Timing Diagram



1 Mbit / 2 Mbit / 4 Mbit Multi-Purpose Flash

SST39LF010 / SST39LF020 / SST39LF040

SST39VF010 / SST39VF020 / SST39VF040

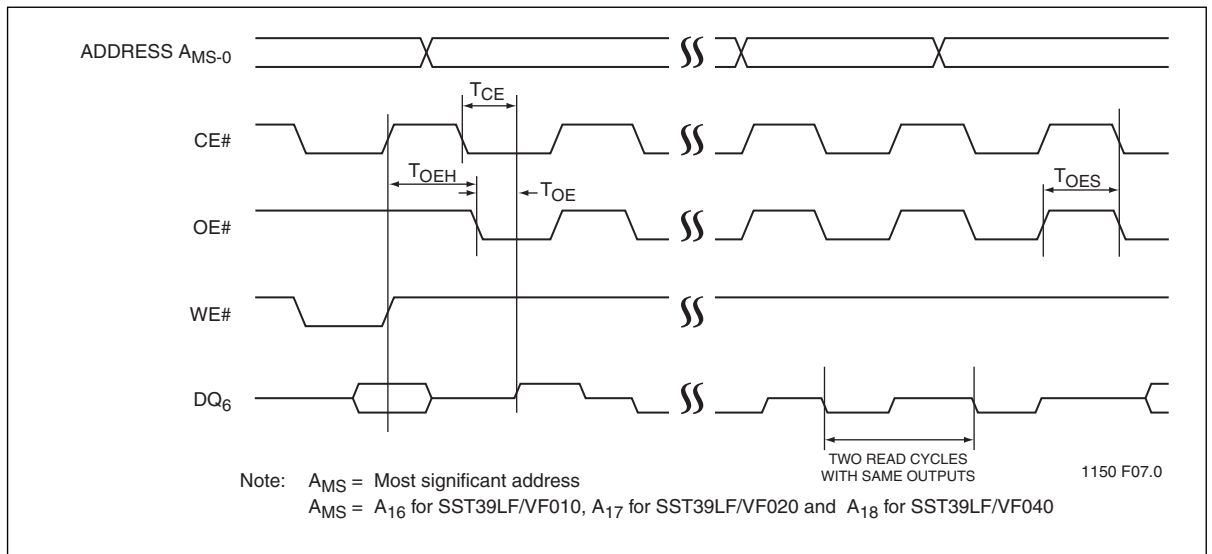

Figure 10: Toggle Bit Timing Diagram

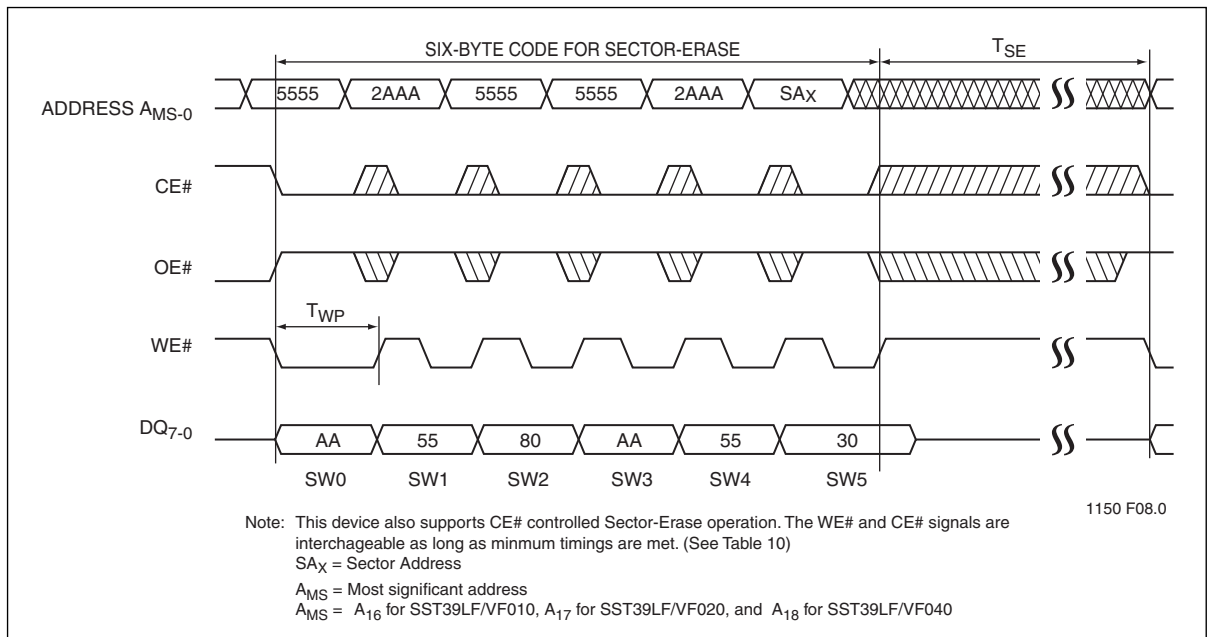

Figure 11: WE# Controlled Sector-Erase Timing Diagram



1 Mbit / 2 Mbit / 4 Mbit Multi-Purpose Flash

SST39LF010 / SST39LF020 / SST39LF040

SST39VF010 / SST39VF020 / SST39VF040

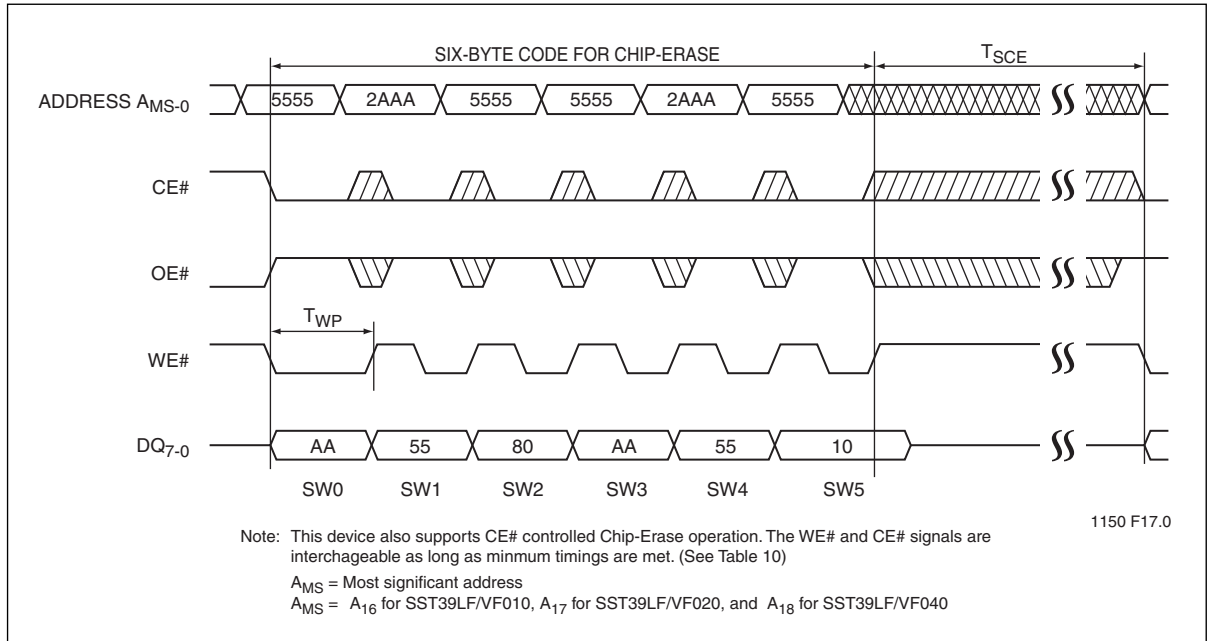

Figure 12: WE# Controlled Chip-Erase Timing Diagram

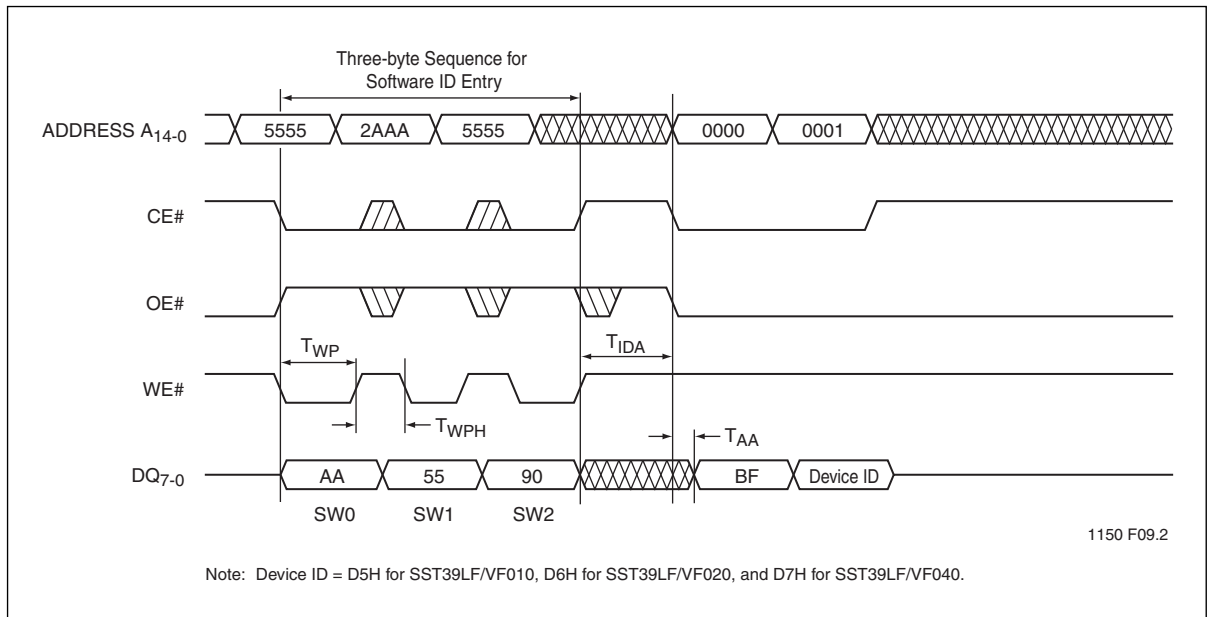

Figure 13: Software ID Entry and Read



1 Mbit / 2 Mbit / 4 Mbit Multi-Purpose Flash

SST39LF010 / SST39LF020 / SST39LF040
SST39VF010 / SST39VF020 / SST39VF040

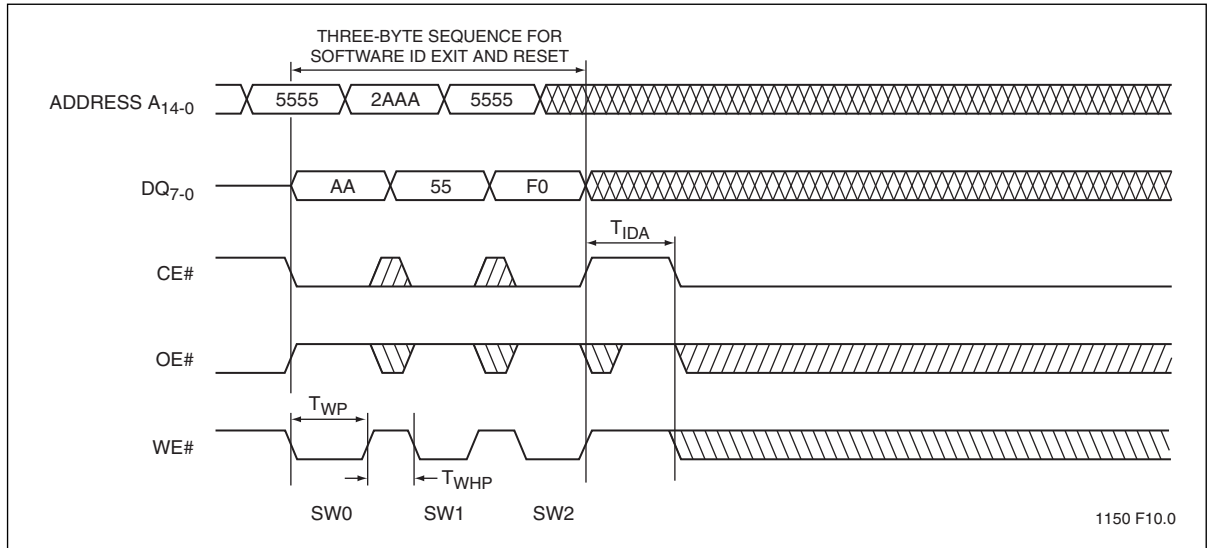

Figure 14: Software ID Exit and Reset

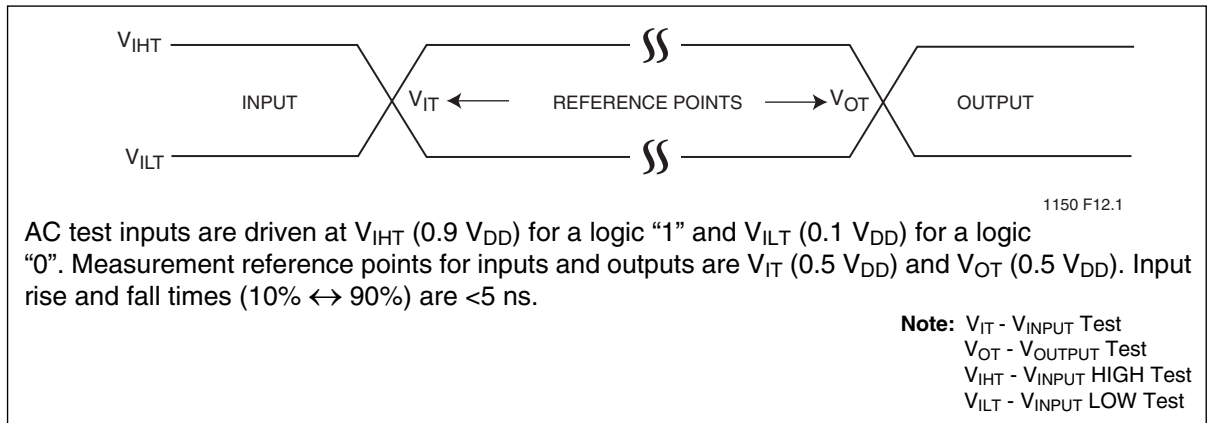

Figure 15: AC Input/Output Reference Waveforms

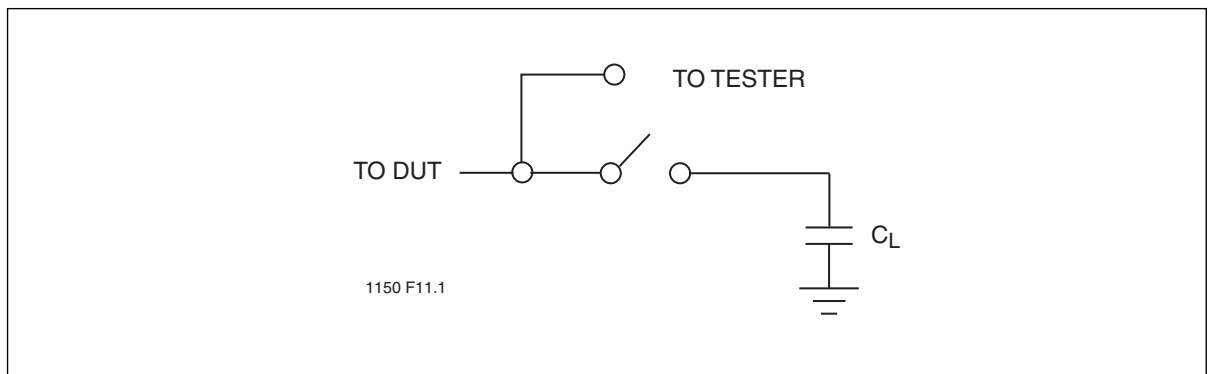

Figure 16: A Test Load Example



1 Mbit / 2 Mbit / 4 Mbit Multi-Purpose Flash

SST39LF010 / SST39LF020 / SST39LF040
SST39VF010 / SST39VF020 / SST39VF040

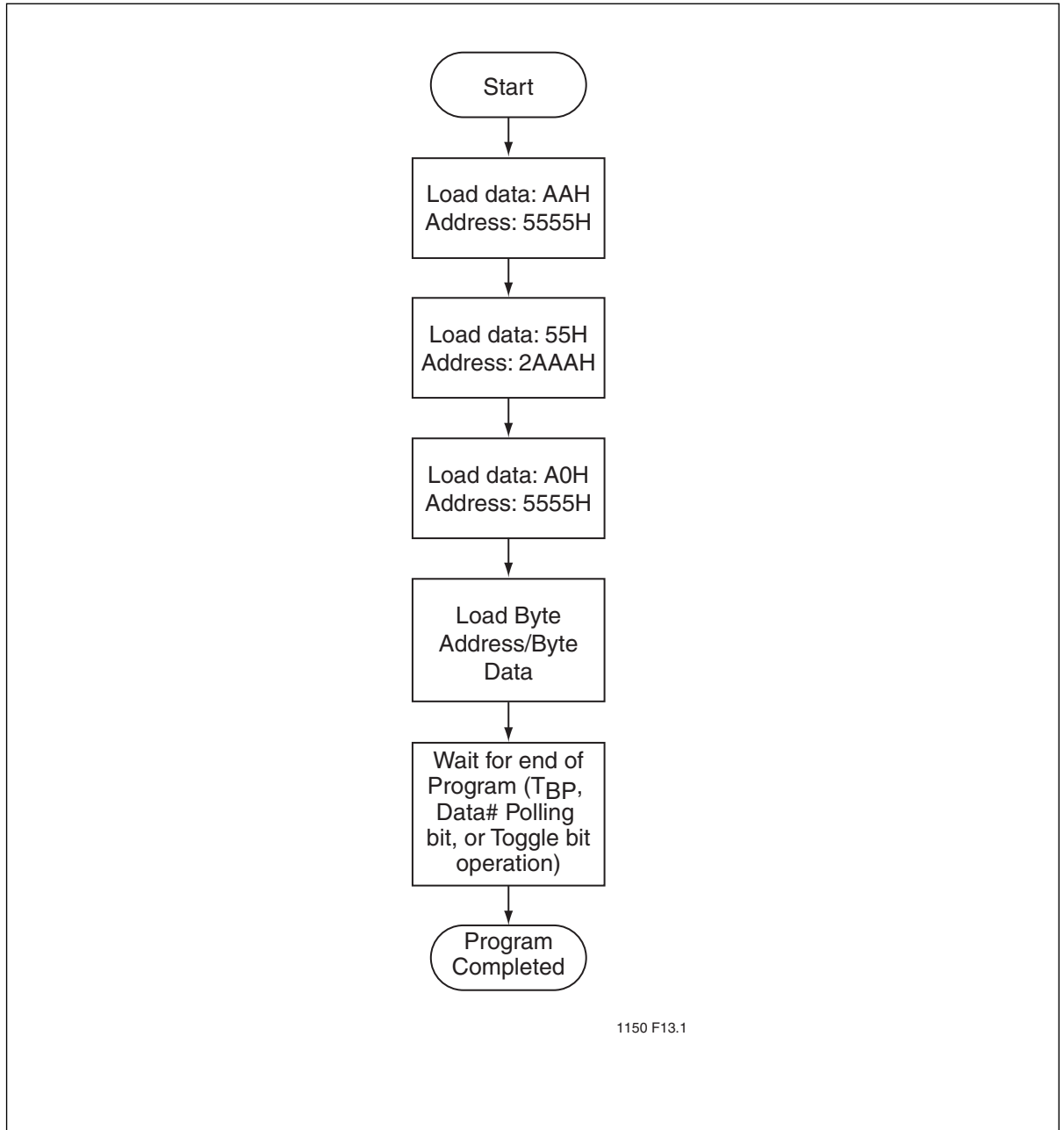

Figure 17:Byte-Program Algorithm



1 Mbit / 2 Mbit / 4 Mbit Multi-Purpose Flash

SST39LF010 / SST39LF020 / SST39LF040
SST39VF010 / SST39VF020 / SST39VF040

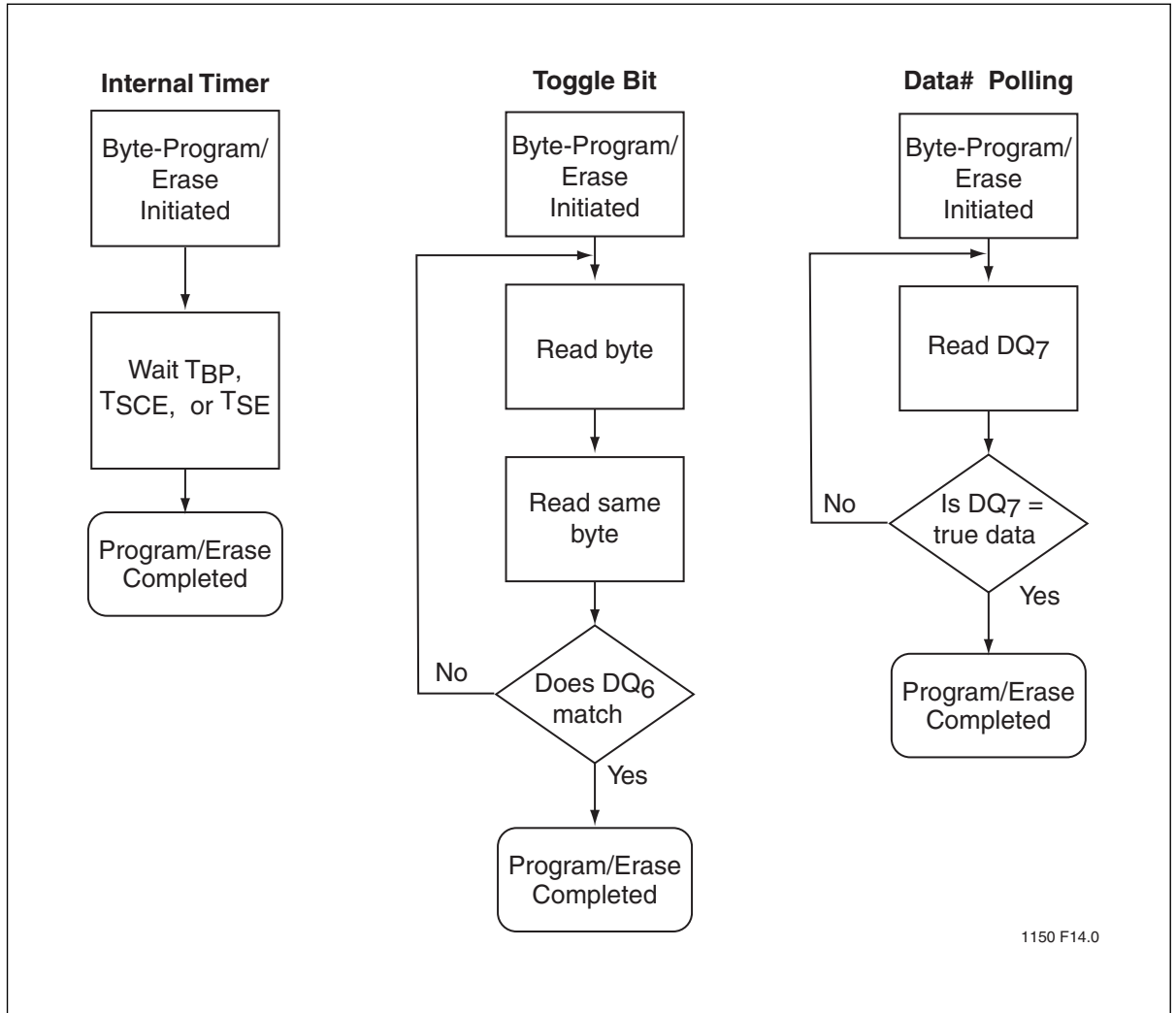

Figure 18: Wait Options



1 Mbit / 2 Mbit / 4 Mbit Multi-Purpose Flash

SST39LF010 / SST39LF020 / SST39LF040
SST39VF010 / SST39VF020 / SST39VF040

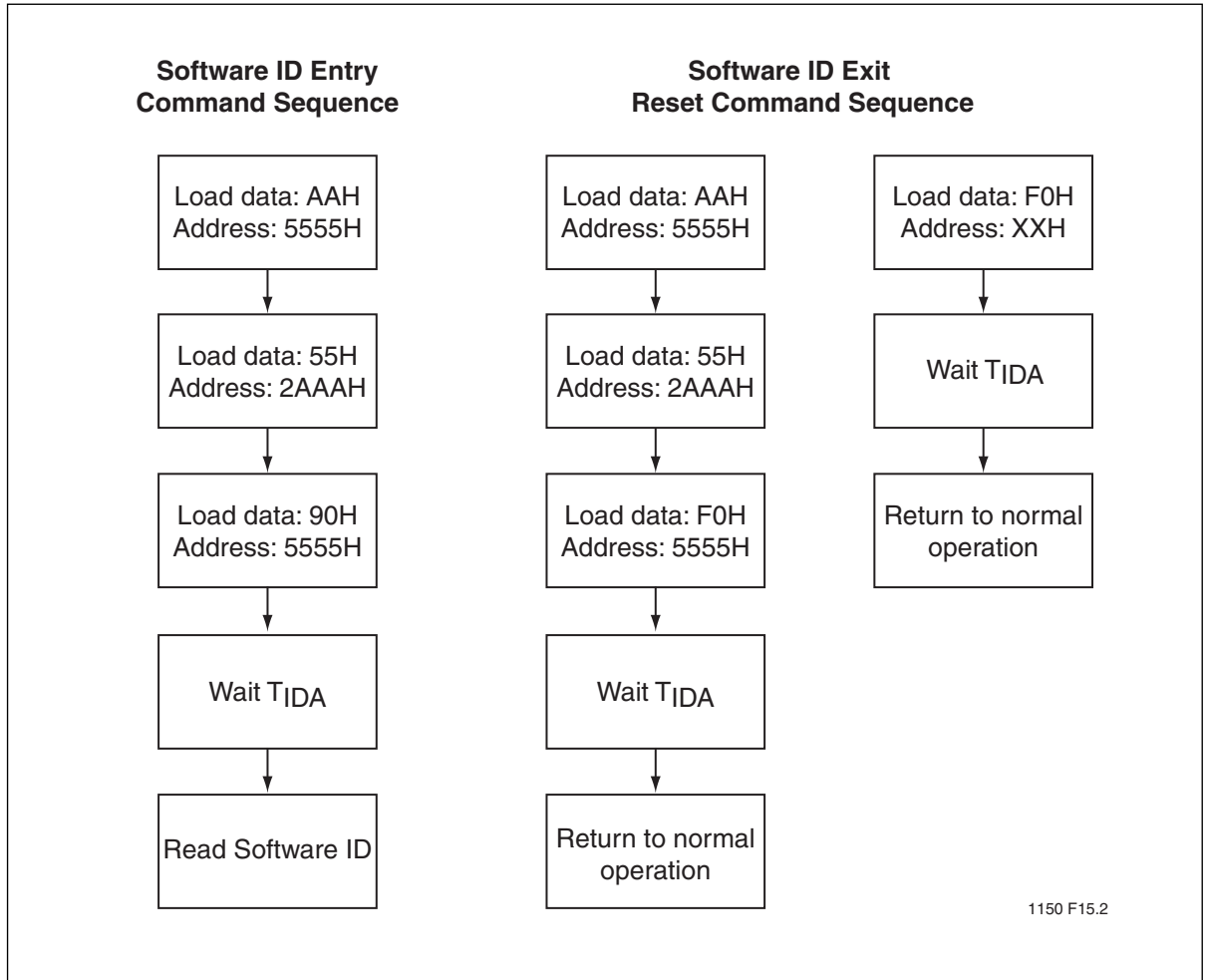
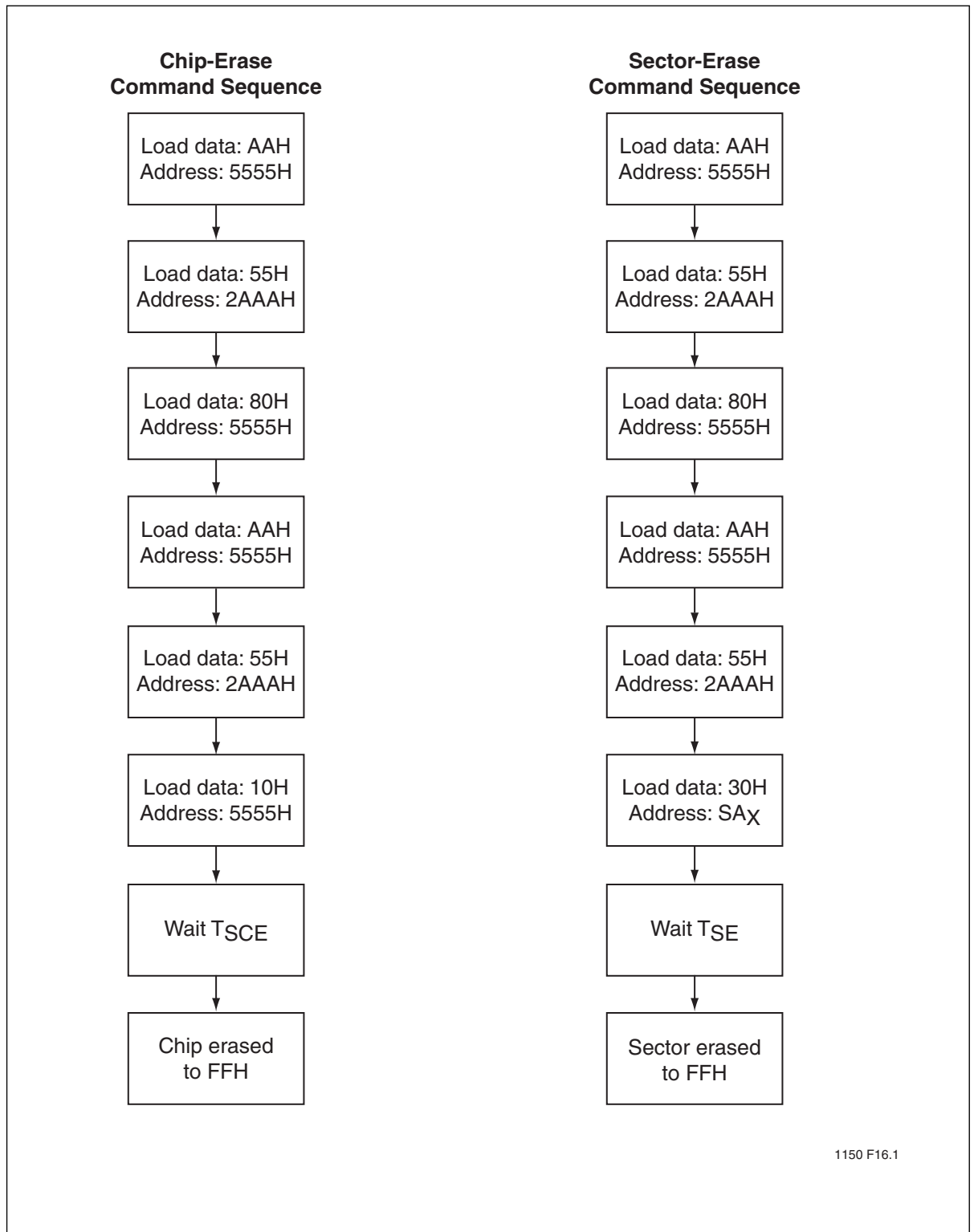

Figure 19: Software ID Command Flowcharts



1 Mbit / 2 Mbit / 4 Mbit Multi-Purpose Flash

SST39LF010 / SST39LF020 / SST39LF040
SST39VF010 / SST39VF020 / SST39VF040



1150 F16.1

Figure 20: Erase Command Sequence



1 Mbit / 2 Mbit / 4 Mbit Multi-Purpose Flash

SST39LF010 / SST39LF020 / SST39LF040
SST39VF010 / SST39VF020 / SST39VF040

Product Ordering Information

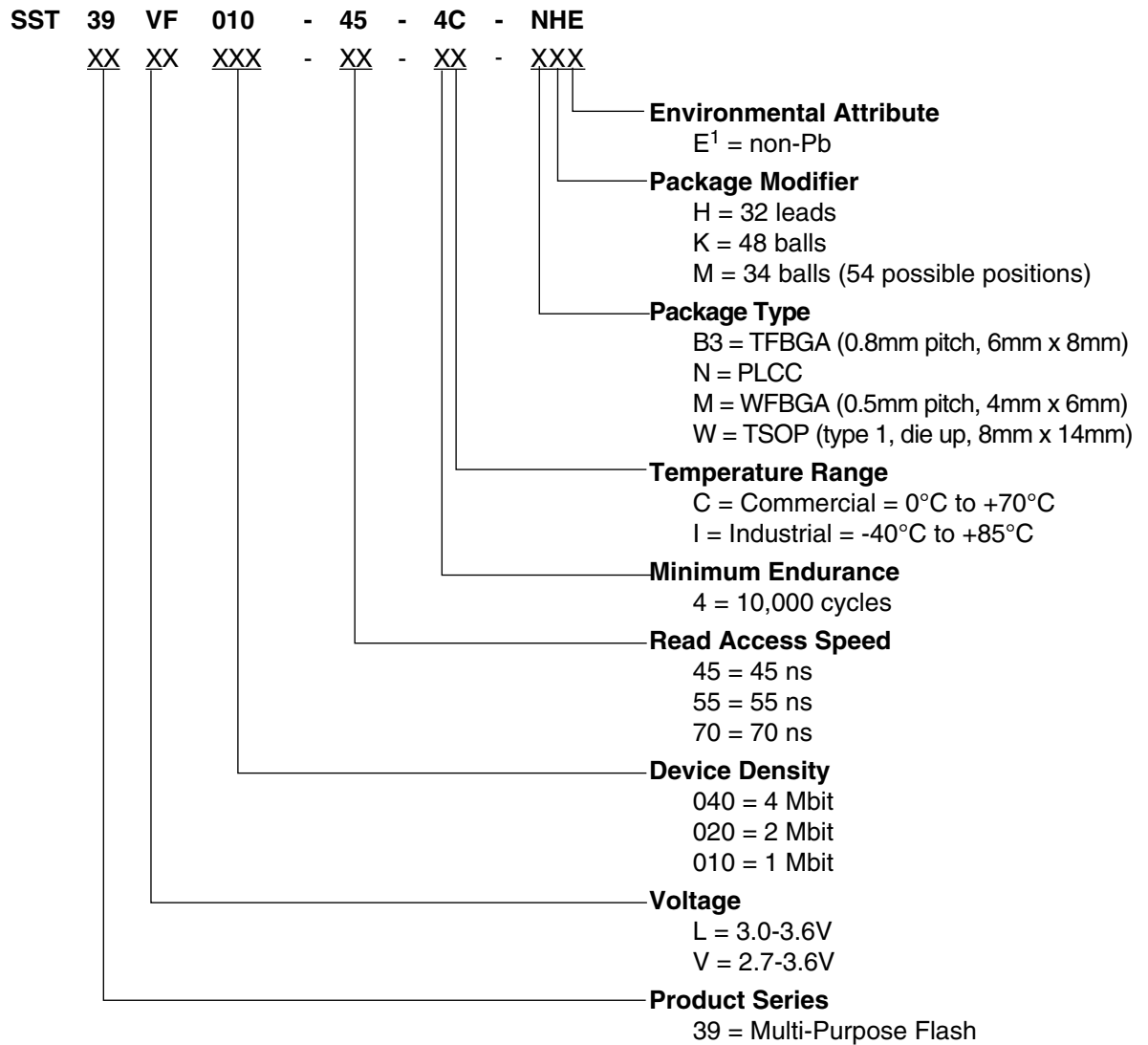

1. Environmental suffix "E" denotes non-Pb solder. SST non-Pb solder devices are RoHS compliant.



1 Mbit / 2 Mbit / 4 Mbit Multi-Purpose Flash

SST39LF010 / SST39LF020 / SST39LF040

SST39VF010 / SST39VF020 / SST39VF040

Valid combinations for SST39LF010

SST39LF010-45-4C-NHE	SST39LF010-45-4C-WHE	SST39LF010-45-4C-B3KE
SST39LF010-45-4C-MME		

Valid combinations for SST39VF010

SST39VF010-70-4C-NHE	SST39VF010-70-4C-WHE	SST39VF010-70-4C-B3KE
SST39VF010-70-4I-NHE	SST39VF010-70-4I-WHE	SST39VF010-70-4I-B3KE

Valid combinations for SST39LF020

SST39LF020-45-4C-NHE	SST39LF020-45-4C-WHE	SST39LF020-45-4C-B3KE
SST39LF020-45-4C-MME		
SST39LF020-55-4C-NHE	SST39LF020-55-4C-WHE	

Valid combinations for SST39VF020

SST39VF020-70-4C-NHE	SST39VF020-70-4C-WHE	SST39VF020-70-4C-B3KE
SST39VF020-70-4I-NHE	SST39VF020-70-4I-WHE	SST39VF020-70-4I-B3KE

Valid combinations for SST39LF040

SST39LF040-45-4C-NHE	SST39LF040-45-4C-WHE	SST39LF040-45-4C-B3KE
SST39LF040-55-4C-NHE	SST39LF040-55-4C-WHE	

Valid combinations for SST39VF040

SST39VF040-70-4C-NHE	SST39VF040-70-4C-WHE	SST39VF040-70-4C-B3KE
SST39VF040-70-4I-NHE	SST39VF040-70-4I-WHE	SST39VF040-70-4I-B3KE

Note: Valid combinations are those products in mass production or will be in mass production. Consult your SST sales representative to confirm availability of valid combinations and to determine availability of new combinations.



1 Mbit / 2 Mbit / 4 Mbit Multi-Purpose Flash SST39LF010 / SST39LF020 / SST39LF040 SST39VF010 / SST39VF020 / SST39VF040

Packaging Diagrams

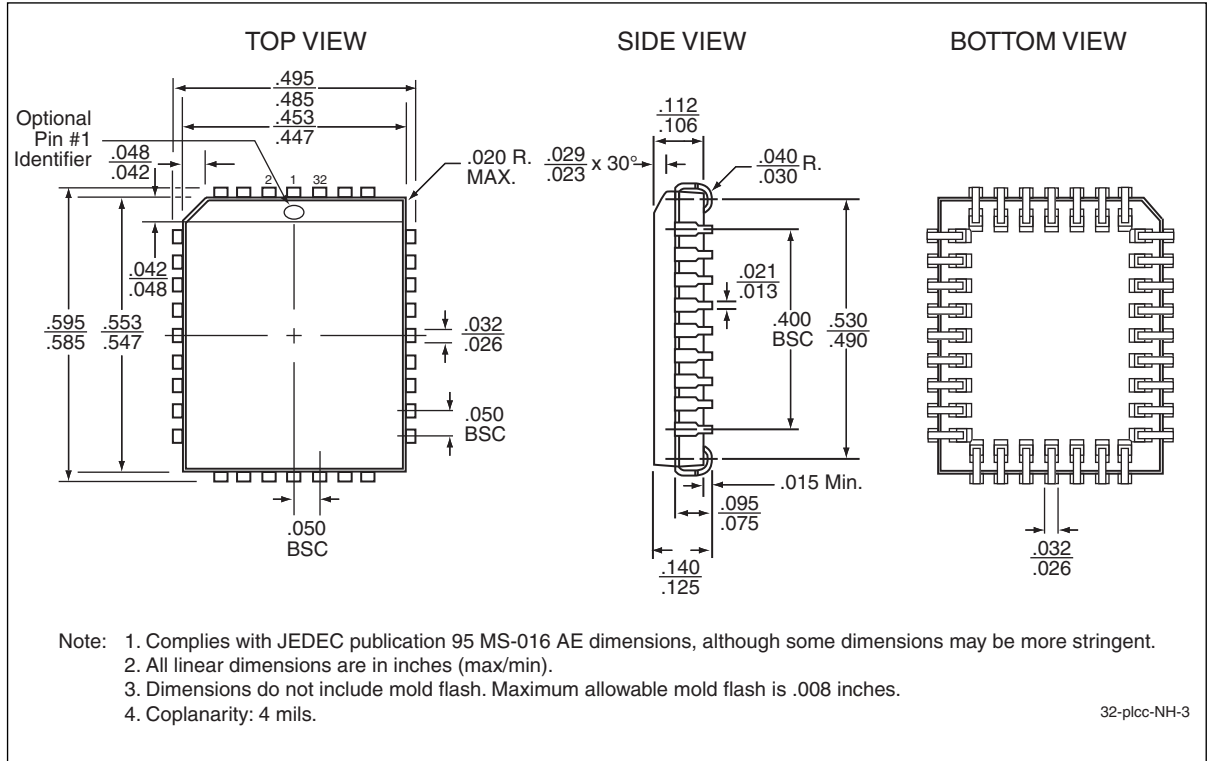

Figure 21: 32-lead Plastic Lead Chip Carrier (PLCC)
SST Package Code: NH



1 Mbit / 2 Mbit / 4 Mbit Multi-Purpose Flash SST39LF010 / SST39LF020 / SST39LF040 SST39VF010 / SST39VF020 / SST39VF040

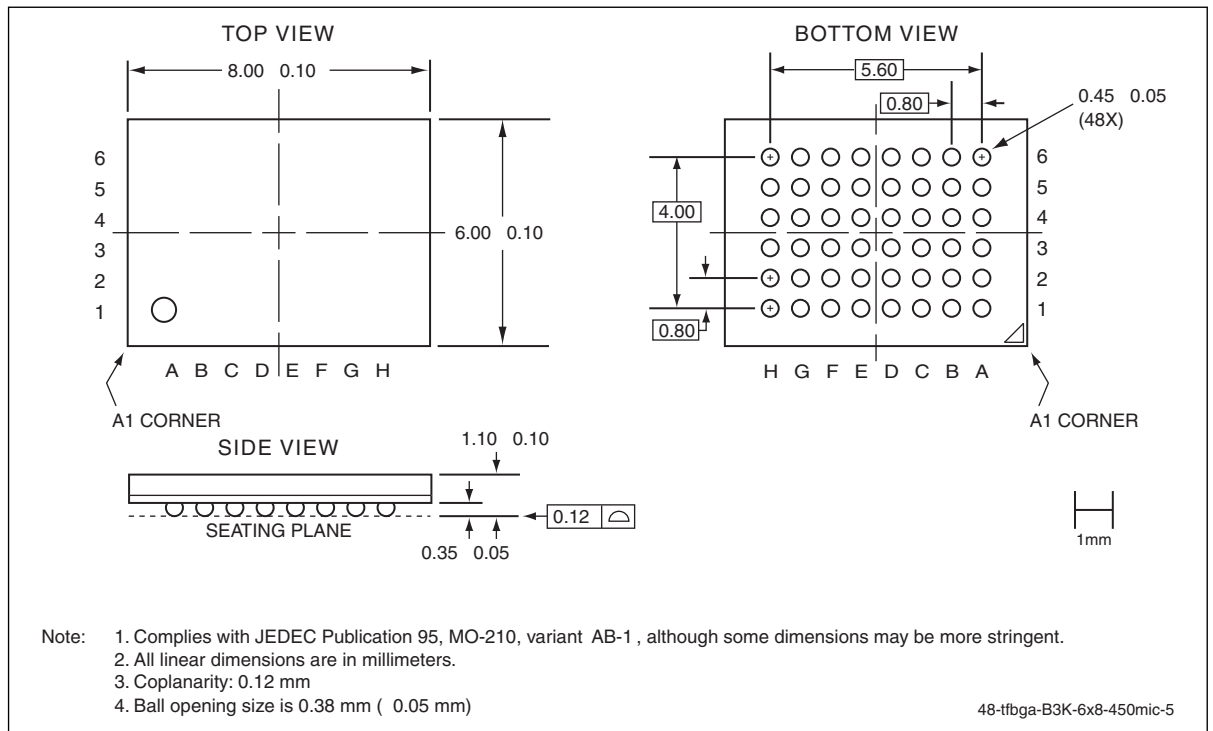

Figure 22:48-ball Thin-profile, Fine-pitch Ball Grid Array (TFBGA) 6mm x 8mm
SST Package Code: B3K



1 Mbit / 2 Mbit / 4 Mbit Multi-Purpose Flash

SST39LF010 / SST39LF020 / SST39LF040
SST39VF010 / SST39VF020 / SST39VF040

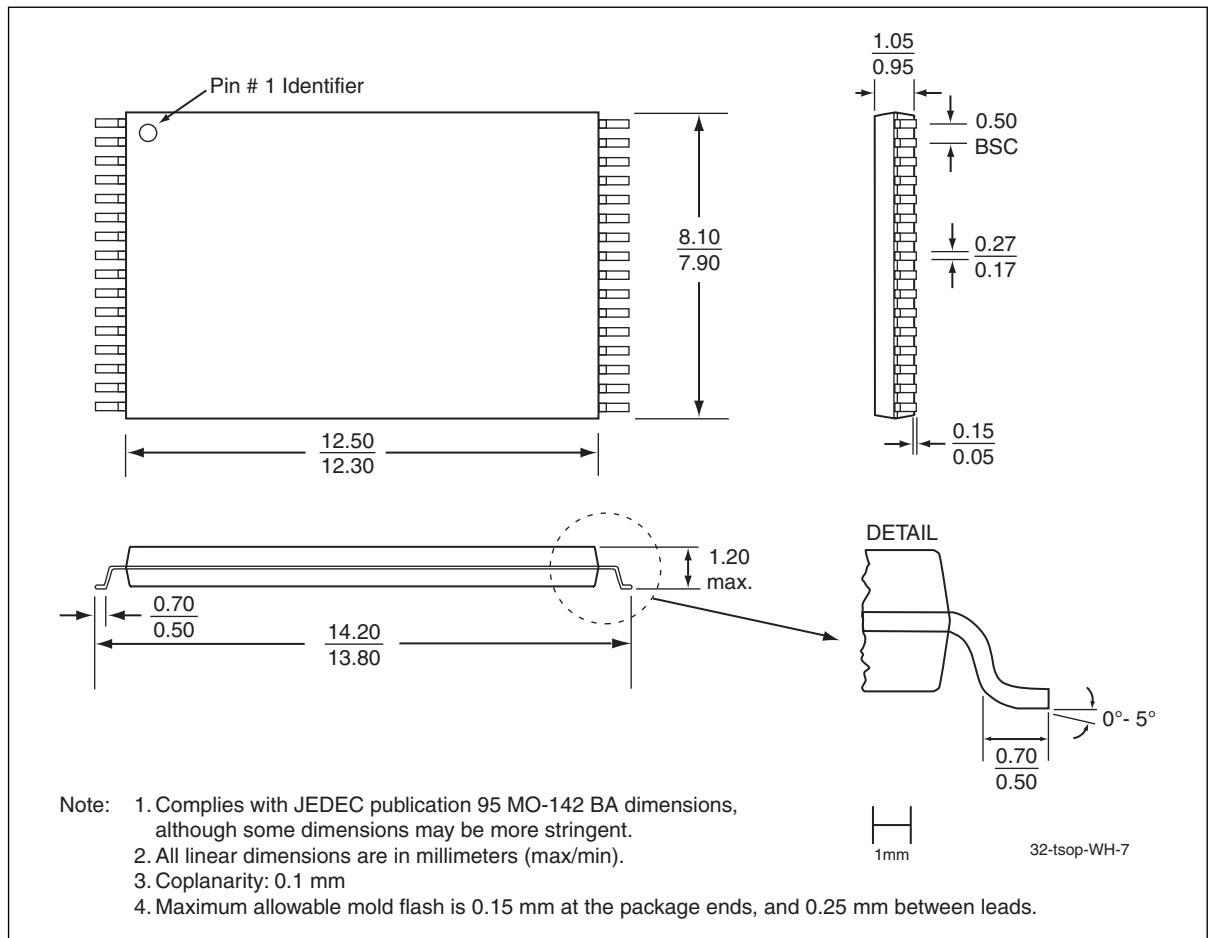

Figure 23: 32-lead Thin Small Outline Package (TSOP) 8mm x 14mm
SST Package Code: WH



1 Mbit / 2 Mbit / 4 Mbit Multi-Purpose Flash SST39LF010 / SST39LF020 / SST39LF040 SST39VF010 / SST39VF020 / SST39VF040

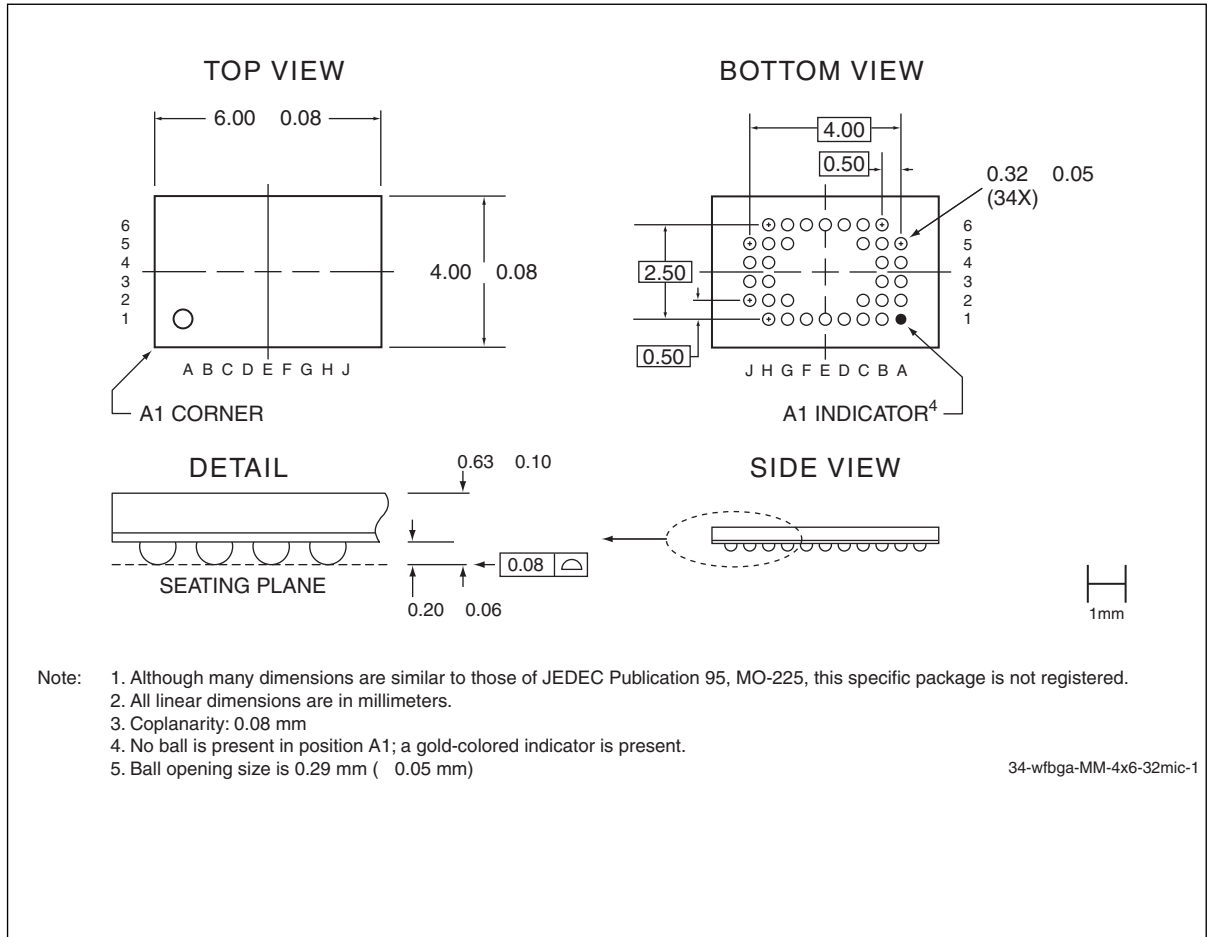

Figure 24: 34-ball Very-very-thin-profile, Fine-pitch Ball Grid Array (WFBGA) 4mm x 6mm x.63mm
SST Package Code: MM



1 Mbit / 2 Mbit / 4 Mbit Multi-Purpose Flash

SST39LF010 / SST39LF020 / SST39LF040

SST39VF010 / SST39VF020 / SST39VF040

Table 14: Revision History

Number	Description	Date
01	<ul style="list-style-type: none"> 2000 Data Book 	Feb 2000
02	<ul style="list-style-type: none"> Changed speed from 45 ns to 55 ns for the SST39LF020 and SST39LF040 	Aug 2000
03	<ul style="list-style-type: none"> 2002 Data Book: Reintroduced the 45 ns parts for the SST39LF020 and SST39LF040 	Feb 2002
04	<ul style="list-style-type: none"> Added the B3K package for the 2 Mbit devices Added footnote in Table 8 to indicate I_{DD} Write is 30 mA max for Erase operations in the Industrial temperature range. 	Oct 2002
05	<ul style="list-style-type: none"> Changes to Table 8 on page 13 <ul style="list-style-type: none"> Added footnote for MPF power usage and Typical conditions Clarified the Test Conditions for Power Supply Current and Read parameters Clarified I_{DD} Write to be Program and Erase Corrected I_{DD} Program and Erase from 20 mA to 30 mA Part number changes - see page 24 for additional information 	Mar 2003
06	<ul style="list-style-type: none"> Added new "MM" Micro-Package MPNs for 1M and 2M LF parts- see page 24 	Oct 2003
07	<ul style="list-style-type: none"> 2004 Data Book Added non-Pb MPNs and removed footnote (See page 24) Updated B3K and MM package diagrams 	Nov 2003
08	<ul style="list-style-type: none"> Added RoHS Compliant statement. Added 4 MBit to Figure 4. Revised Absolute Max Stress Ratings for Surface Mount Solder Reflow Temperature Removed SST39VFxxx-90 Timing Parameters from Figure 12. Added Footnote and removed Read Access Speed 90 = 90 to Product Ordering Information. Removed 90 part numbers Valid Combinations lists 	Dec 2005
09	<ul style="list-style-type: none"> Edited page Valid Combinations on page 21. Changed 39LF040-70-4C-B3KE to 39LF040-45-4C-B3KE 	Jan 2006
10	<ul style="list-style-type: none"> Removed leaded parts 	Nov 2008
11	<ul style="list-style-type: none"> Added package YME 	Feb 2009
12	<ul style="list-style-type: none"> Revised "Product Ordering Information" on page 24 	Apr 2009
13	<ul style="list-style-type: none"> Changed endurance from 10,000 to 100,000 in Product Description, page 1 	Sep 2009
14	<ul style="list-style-type: none"> EOL of SST39LF010-45-4C-YME. Replacement part is SST39LF010-45-4C-MME in this document. Removed all references to the YME package. 	Jan 2010
A	<ul style="list-style-type: none"> EOL of SST39LF512 and SST39VF512 parts. Replacement parts are SST39LF010 and SST39VF010. Applied new document format. Released document under letter revision system. Updated spec number S71150 to DS25023. 	Aug 2011



A Microchip Technology Company

1 Mbit / 2 Mbit / 4 Mbit Multi-Purpose Flash

SST39LF010 / SST39LF020 / SST39LF040

SST39VF010 / SST39VF020 / SST39VF040

Data Sheet

ISBN:978-1-61341-479-8

© 2011 Silicon Storage Technology, Inc—a Microchip Technology Company. All rights reserved.

SST, Silicon Storage Technology, the SST logo, SuperFlash, MTP, and FlashFlex are registered trademarks of Silicon Storage Technology, Inc. MPF, SQI, Serial Quad I/O, and Z-Scale are trademarks of Silicon Storage Technology, Inc. All other trademarks and registered trademarks mentioned herein are the property of their respective owners.

Specifications are subject to change without notice. Refer to www.microchip.com for the most recent documentation. For the most current package drawings, please see the Packaging Specification located at <http://www.microchip.com/packaging>.

Memory sizes denote raw storage capacity; actual usable capacity may be less.

SST makes no warranty for the use of its products other than those expressly contained in the Standard Terms and Conditions of Sale.

For sales office locations and information, please see www.microchip.com.

Silicon Storage Technology, Inc.
A Microchip Technology Company
www.microchip.com
