

GOLD SERIES DIRECTIONAL YAGI ANTENNAS PROVIDE INDUSTRY-LEADING DESIGN FEATURES WITH LONG TERM OPTIMAL PERFORMANCE

Laird's premium series directional Yagi antennas are fully gold anodized for corrosion resistance. All UHF and above frequency antennas feature internal matching to assure broad bandwidth and resistance to severe weather conditions. There is no gamma match to ice up, corrode or detune. Our engineering staff has optimized the product family for forward gain by computer analysis and then field-tested each for conformance.

FEATURES AND BENEFITS:

- All UHF and higher frequency antennas feature 360° welds around each element and an end-of-boom N connector feed with an internal transmission line feeding the driven element.
- Every Yagi is tuned on a network analyzer for best power match and lowest VSWR.
- All Yagi antennas ship complete with a high quality cast aluminum mounting kit that includes stainless steel hardware and allows vertical or horizontal orientation during installation (VHF models require light assembly).

APPLICATIONS:

- Point-to-point and multi-point / omnidirectional outdoor antennas applications used by private organizations and government agencies around the globe.
- Typical applications include transportation such as railroad switching, remote locations reporting examples that include oil fields, weather conditions and, meter data transmissions for utilities.

ELECTRICAL	
Frequency Range	896 – 970 MHz
Gain	11 dBd
Front - Back Ratio	20 dB
Maximum Power	500 W
Input Impedance	50 ohms

MECHANICAL	
Elements	12
Element Material	3/8" Diameter solid 6061-T6 aluminum rod
Boom Element	Heat treated 6061-T6 aluminum tube
Assembly	Fully Welded
Length	49 inches
Shipping	All models are UPS shippable
Mounting	Up to 2 inch mast
Hardware	Stainless steel
Termination Type	N female at the end of the boom
Lightning Protection	DC grounded
Rated Wind Velocity	100 MPH

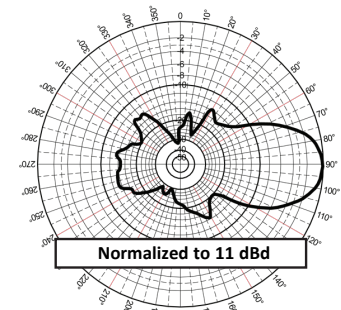

Vertical-to-Vertical Polarization Azimuthal Pattern (Y, Z, or E-plane)

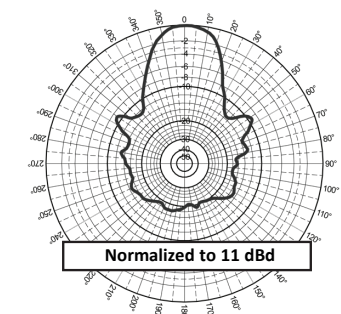

Horizontal-to-Horizontal Polarization Azimuthal Pattern (Y, Z, or H-plane)

Americas: +1.847.839.6907
IAS-AmericasEastSales@lairdtech.com

Europe: +44.1628.858941
IAS-EUSales@lairdtech.com

Asia: +86.21.5855.0827.127
IAS-AsiaSales@lairdtech.com

www.lairdtech.com

ANT-DS-Y(B)89612 0115

Any information furnished by Laird Inc. and its agents is believed to be accurate and reliable. All specifications are subject to change without notice. Responsibility for the use and application of Laird materials rests with the end user, since Laird and its agents cannot be aware of all potential uses. Laird makes no warranties as to the fitness, merchantability or suitability of any Laird materials or products for any specific or general uses. Laird shall not be liable for incidental or consequential damages of any kind. All Laird products are sold pursuant to the Laird Terms and Conditions of sale in effect from time to time, a copy of which will be furnished upon request. © Copyright 2015 Laird Inc. All Rights Reserved. Laird, Laird Technologies, the Laird Logo, and other marks are trade marks or registered trade marks of Laird Inc. or an affiliate company thereof. Other product or service names may be the property of third parties. Nothing herein provides a license under any Laird or any third party intellectual property rights.