



The TC-XX-SR-54 temperature controller is a microcontroller based device that can be incorporated into a thermoelectric assembly (TEA) to add integrated temperature control. The TC-XX-SR-54 is a bi-polar temperature controller for cooling/heating of thermoelectric assemblies requiring precise temperature control accuracy. The TC-XX-SR-54 has 3 programmable fan outputs, alarm output relay, alarm condition LEDs. The parameters will be programmed at the factory according to the customer requirements. Custom configurations are available, however MOQ applies.

### FEATURES

- Operation in cooling and heating modes
- Regulation mode is ON/OFF, PID, Power
- Input power range can accommodate 16 to 60 VDC, nominally 16 to 48 VDC
- Preprogrammed set points
- Contacts are available for fans, thermoelectric modules, NTC thermistor sensor, overheating thermostat switch, alarms; some features sold on custom configurations only
- USB communication interface

### MARKETS

- Battery Backup Cabinets
- Medical diagnostics
- Analytical instrumentation
- Chillers (liquid cooling)

### BENEFITS

- Standalone operation
- Control temperature, from -20°C to +100°C (-4°F to +212°F) with the standard NTC sensor
- Temperature resolution of max +0.13°C
- Use with NTC sensors only
- Pulse width modulation of output: (Base frequency of 8 kHz)
- Control stability of ±0.13°C (-20° to +50°C)
- Three alarm temperature sensor inputs with adjustable alarm set points
- Alarm relay output, normally closed (will open on alarm): 1A at 125VAC/110VDC
- Adjustable fan speed
- Tachometer sensor inputs provided to measure the speed of one external and two internal fans
- Overheating thermostat switch input available to sense an over temperature condition that will turn off power to TEA/fans and microcontroller; a thermostat is required for operation
- Alarm LED outputs available indicate type of failure

PERFORMANCE	SPECIFICATIONS
<b>Power</b>	
Voltage	16 to 60 VDC
Current	Max 20A Continuous @ 50°C ambient @ 28VDC Max 12A Continuous @ 50°C ambient @ 60VDC
Power	560W @ 28VDC MAX, 720W @ 60VDC Max
<b>Sensors</b>	
Temp Sensor	NTC thermistor, 3 temperature sensor inputs available
Fan Internal 1 Tachometer	Use with fans w/ an open collector tachometer
Fan Internal 2 Tachometer	Use with fans w/ an open collector tachometer
Fan External Tachometer	Use with fans w/ an open collector tachometer
<b>Outputs</b>	
Thermoelectric Module	Max 15A Continuous @ 50°C ambient @ 28VDC Max 10A Continuous @ 50°C ambient @ 60VDC PWM output at 8KHz
Fan Internal 1	Max 1A Continuous @ 50°C ambient @ 28VDC Max 0.5A Continuous @ 50°C ambient @ 60VDC
Fan Internal 2	Max 1A Continuous @ 50°C ambient @ 28VDC Max 0.5A Continuous @ 50°C ambient @ 60VDC
Fan External	Max 2.5A Continuous @ 50°C ambient @ 28VDC Max 1.25A Continuous @ 50°C ambient @ 60VDC
PWM output for FANS	15V, 1KHz
Alarm Relay	<b>Default:</b> Relay with 3 contacts (NO,NC, COM) Contact max current is 1A at 125VAC/110VDC <b>Optional:</b> Optocouple isolated NO/NC: 2 contacts
Overheating Thermostat	External Overheating protection thermostat of 15V, min of 0.5A can be connected (optional)
LED	Status/Errors

Americas: +1 919.597.7300

Europe: +46.31.420530

Asia: +86.755.2714.1166

clv.customerpos@lairdtech.com

www.lairdtech.com

PERFORMANCE	SPECIFICATIONS
<b>Alarms</b>	
Low Voltage	If voltage is lower than programmed minimum level the outputs are shut down
High Voltage	Outputs are shut down instantly
Battery Delimiter	Turns on the modules and fans only if battery voltage is above DELIM_H value and turns off everything if battery voltage drops below DELIM_L
Tachometer Int Fan 1 & 2, Ext Fan	If the RPM signal is lower/higher than the programmed minimum/maximum level, error is indicated and outputs can be turned off
Fan Failure/Missing	If fan rotor fails, fault is indicated
Fan Overcurrent	If fan draws over current
Temperature Sensors 1,2/3 short/open/out of range	If the temperature sensors are short/open or out of range, fault is detected and outputs can be turned off
TEM Over Current/Missing	Fault is indicated and fans outputs can be turned off
Note: All programming of parameters are conducted by Laird	
<b>Temperature Regulation</b>	
ON/OFF mode (dual set point)	Controller switches the TEM output between full power and zero power at the programmed set point and hysteresis
PID mode ( single set point)	Controller can be selected to switch between P, PI, PD or PID modes
PID mode ( Dual set point)	Controller can be selected to switch between P, PI, PD or PID modes
Power mode	Depending on the value of external potentiometer the output can be controlled
Programmable Control Set Point/s	Can be programmed at any value between -40°C to +150°C
Temperature resolution	Max resolution of $\pm 0.15^{\circ}\text{C}$ (set point range of $0^{\circ}\text{C}$ to $+50^{\circ}\text{C}$ )
Accuracy	$\pm 0.5^{\circ}\text{C}$
<b>Protection</b>	
Over and under voltage	Yes
Reverse polarity	Yes
Self start up test	For testing fans, modules and temperature sensor on start up (optional)

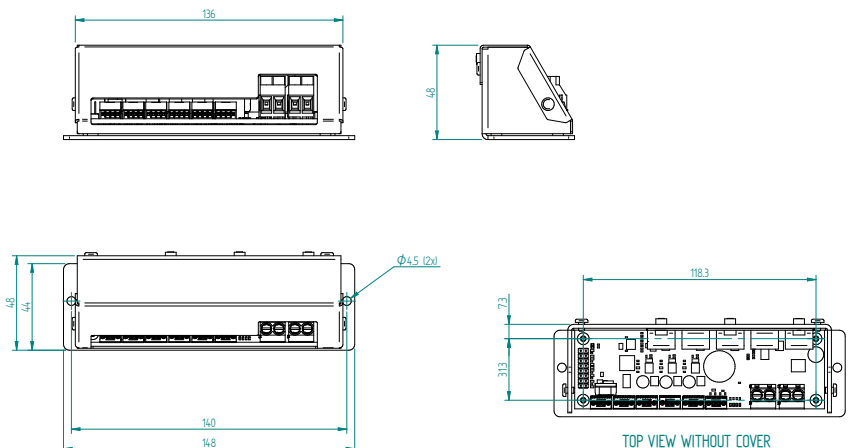
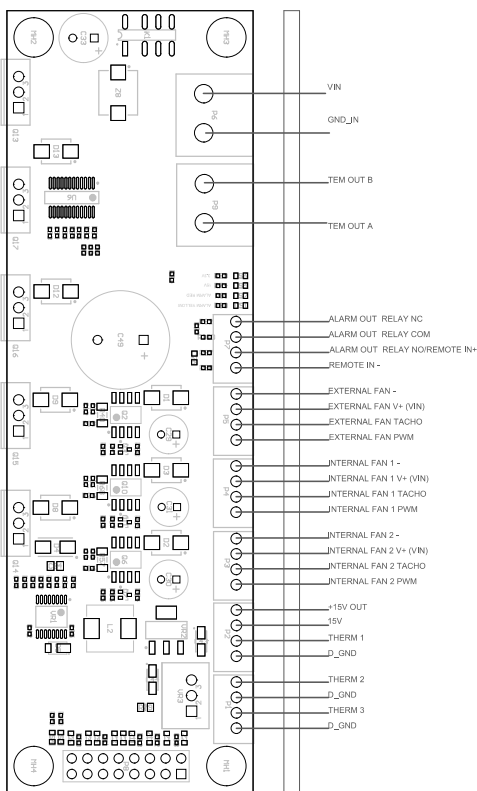

TC-XX-SR-54\_032615

Any information furnished by Laird and its agents is believed to be accurate and reliable. All specifications are subject to change without notice. Responsibility for the use and application of Laird materials rests with the end user, since Laird and its agents cannot be aware of all potential uses. Laird makes no warranties as to the fitness, merchantability or suitability of any Laird materials or products for any specific or general uses. Laird, Laird Technologies, Inc or any of its affiliates or agents shall not be liable for incidental or consequential damages of any kind. All Laird products are sold pursuant to the Laird Technologies' Terms and Conditions of sale in effect from time to time, a copy of which will be furnished upon request. © Copyright 2015 Laird Technologies, Inc. All Rights Reserved. Laird, Laird Technologies, the Laird Logo, and other marks are trademarks or registered trademarks of Laird Technologies, Inc. or an affiliate company thereof. Other product or service names may be the property of third parties. Nothing herein provides a license under any Laird or any third party intellectual property rights.