

Digital Temperature Sensor with SPI Interface

Features

- Temperature-to-Digital Converter
- SPI Compatible Interface
- 10-Bit Resolution (0.25°C/Bit)
- ±2°C (maximum) Accuracy from -40°C to +85°C
- ±3°C (maximum) Accuracy from -55°C to +125°C
- 2.65V to 5.5V Operating Range
- Low Power Consumption:
 - 250 µA (typical) Continuous Temperature Conversion Mode
 - 1 µA (maximum) Shutdown Mode
- Power Saving One-Shot Temperature Measurement
- Industry Standard 8-Pin MSOP Package
- Space Saving 8-Pin DFN (3x3 mm) Package

Typical Applications

- Personal Computers and Servers
- Hard Disk Drives and Other PC Peripherals
- Entertainment Systems
- Office Equipment
- Datacom Equipment
- Mobile Phones
- General Purpose Temperature Monitoring

Package Types

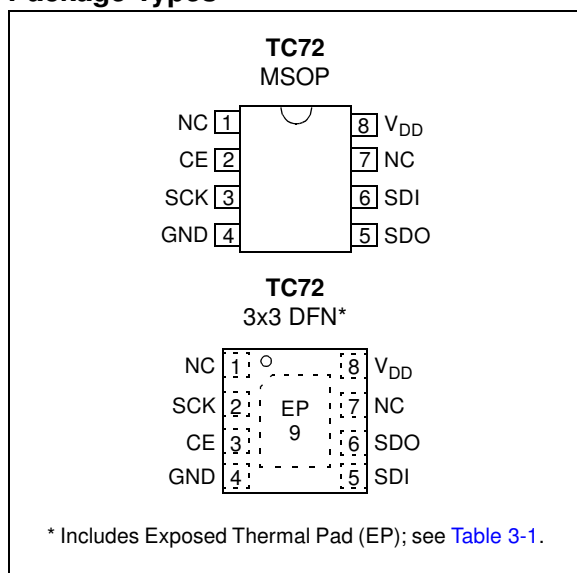

General Description

TC72 is a digital temperature sensor capable of reading temperatures from -55°C to +125°C. This sensor features a serial interface that allows communication with a host controller or other peripherals. The TC72 interface is compatible with the SPI protocol, and does not require any additional external components. However, it is recommended that a decoupling capacitor of 0.01 µF to 0.1 µF be provided between the V_{DD} and GND pins.

TC72 can be used either in a Continuous Temperature Conversion mode or a One-Shot Conversion mode. The Continuous Conversion mode measures the temperature approximately every 150 ms and stores the data in the temperature registers. In contrast, the One-Shot mode performs a single temperature measurement and returns to the power saving shutdown mode.

TC72 features high temperature accuracy, ease-of-use and is the ideal solution for implementing thermal management in a variety of systems. The device is available in both 8-pin MSOP and 8-pin DFN space-saving packages. TC72 also features a Shutdown mode for low power operation.

Block Diagram

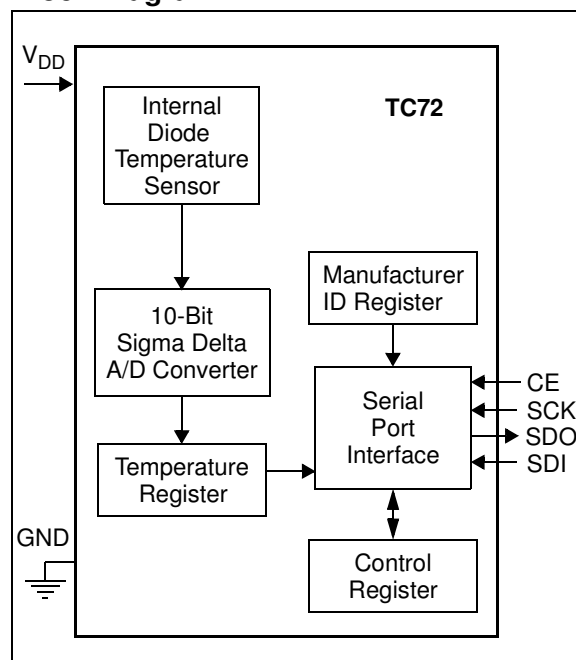

TC72

NOTES:

1.0 ELECTRICAL CHARACTERISTICS

1.1 Maximum Ratings†

V _{DD}	6.0V
All inputs and outputs w.r.t. GND ...	-0.3V to V _{DD} +0.3V
Storage temperature	-65 °C to +150 °C
Ambient temp. with power applied	-55 °C to +125 °C
Junction Temperature	150 °C
ESD protection on all pins:	
Human Body Model (HBM).....	> 4 kV
Man Machine Model (MM).....	> 400V
Latch-Up Current at each pin	±200 mA
Maximum Power Dissipation.....	250 mW

† **Notice:** Stresses above those listed under "Maximum Ratings" may cause permanent damage to the device. This is a stress rating only and functional operation of the device at those or any other conditions above those indicated in the operation listings of this specification is not implied. Exposure to maximum rating conditions for extended periods may affect device reliability.

DC CHARACTERISTICS

Electrical Specifications: Unless otherwise noted, all parameters apply at V _{DD} = 2.65V to 5.5V, T _A = -55 °C to +125 °C.						
Parameters	Sym	Min	Typ	Max	Units	Conditions
Power Supply						
Operating Voltage Range	V _{DD}	2.65	—	5.5	V	Note 1
Operating Current: Normal Mode, ADC Active	I _{DD-CON}	—	250	400	µA	Continuous Temperature Conversion mode (Shutdown Bit = '0')
Shut-Down Supply Current	I _{SHD}	—	0.1	1.0	µA	Shutdown mode (Shutdown Bit = '1')
Temperature Sensor and Analog-to-Digital Converter						
Temperature Accuracy (Note 1)	T _{ACY}	-2.0	—	+2.0	°C	-40 °C < T _A < +85 °C
		-3.0	—	+3.0		-55 °C < T _A < +125 °C
Resolution		—	10	—	Bits	Note 4
ADC Conversion Time	t _{CONV}	—	150	200	ms	
Digital Input / Output						
High Level Input Voltage	V _{IH}	0.7 V _{DD}	—	—	V	
Low Level Input Voltage	V _{IL}	—	—	0.2 V _{DD}	V	
High Level Output Voltage	V _{OH}	0.7 V _{DD}	—	—	V	I _{OH} = 1 mA
Low Level Output Voltage	V _{OL}	—	—	0.2 V _{DD}	V	I _{OL} = 4 mA
Input Resistance	R _{IN}	1.0	—	—	MΩ	
Pin Capacitance	C _{IN}	—	15	—	pF	
	C _{OUT}	—	50	—		

Note 1: The TC72-2.8MXX, TC72-3.3MXX and TC72-5.0MXX will operate from a supply voltage of 2.65V to 5.5V. However, the TC72-2.8MXX, TC72-3.3MXX and TC72-5.0MXX are tested and specified at the nominal operating voltages of 2.8V, 3.3V and 5.0V respectively. As V_{DD} varies from the nominal operating value, the accuracy may be degraded. Refer to [Figure 2-5](#) and [Figure 2-6](#).

2: Measured with a load of C_L = 50 pF on the SDO output pin of the TC72.

3: All time measurements are measured with respect to the 50% point of the signal, except for the SCK rise and fall times. The rise and fall times are defined as the 10% to 90% transition time.

4: Resolution = Temperature Range/No. of Bits = (+127 °C – -128 °C) / (2¹⁰) = 256/1024 = 0.25 °C/Bit

TC72

DC CHARACTERISTICS (CONTINUED)

Electrical Specifications: Unless otherwise noted, all parameters apply at $V_{DD} = 2.65V$ to $5.5V$, $T_A = -55^{\circ}C$ to $+125^{\circ}C$.

Parameters	Sym	Min	Typ	Max	Units	Conditions
Serial Port AC Timing (Note 2, 3)						
Clock Frequency	f_{CLK}	DC	—	7.5	MHz	
SCK Low Time	t_{CL}	65	—	—	ns	
SCK High Time	t_{CH}	65	—	—	ns	
CE to SCK Setup	t_{CC}	400	—	—	ns	
SCK to Data Out Valid	t_{CDD}	—	—	55	ns	
CE to Output Tri-state	t_{CDZ}	—	—	40	ns	
SCK to Data Hold Time	t_{CDH}	35	—	—	ns	
Data to SCK Set-up Time	t_{DC}	35	—	—	ns	
SCK to CE Hold Time	t_{CCH}	100	—	—	ns	
SCK Rise Time	t_R	—	—	200	ns	
SCK Fall Time	t_F	—	—	200	ns	
CE Inactive Time	t_{CWH}	400	—	—	ns	

Note 1: The TC72-2.8MXX, TC72-3.3MXX and TC72-5.0MXX will operate from a supply voltage of 2.65V to 5.5V. However, the TC72-2.8MXX, TC72-3.3MXX and TC72-5.0MXX are tested and specified at the nominal operating voltages of 2.8V, 3.3V and 5.0V respectively. As V_{DD} varies from the nominal operating value, the accuracy may be degraded. Refer to [Figure 2-5](#) and [Figure 2-6](#).

2: Measured with a load of $C_L = 50$ pF on the SDO output pin of the TC72.

3: All time measurements are measured with respect to the 50% point of the signal, except for the SCK rise and fall times. The rise and fall times are defined as the 10% to 90% transition time.

4: Resolution = Temperature Range/No. of Bits = $(+127^{\circ}C - -128^{\circ}C) / (2^{10}) = 256/1024 = 0.25^{\circ}C/Bit$

TEMPERATURE SPECIFICATION

Electrical Specifications: Unless otherwise noted, all parameters apply at $V_{DD} = 2.65V$ to $5.5V$, $T_A = -55^{\circ}C$ to $+125^{\circ}C$.

Parameters	Sym	Min	Typ	Max	Units	Conditions
Temperature Ranges						
Specified Temperature Range	T_A	-55	—	+125	$^{\circ}C$	
Operating Temperature Range	T_A	-55	—	+125	$^{\circ}C$	
Storage Temperature Range	T_A	-65	—	+150	$^{\circ}C$	
Thermal Package Resistances						
Thermal Resistance 8-L 3x3 DFN	θ_{JA}	—	56.7	—	$^{\circ}C/W$	
Thermal Resistance 8-L MSOP	θ_{JA}	—	211	—	$^{\circ}C/W$	

SPI READ DATA TRANSFER

(CP = 0, data shifted on rising edge of SCK, data clocked on falling edge of SCK, A7 = 0)

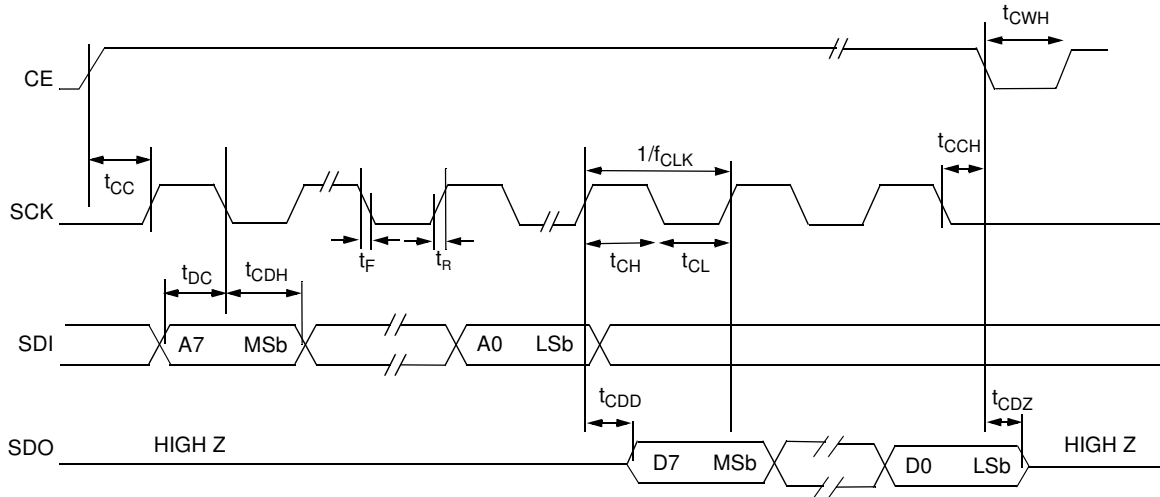

SPI WRITE DATA TRANSFER

(CP = 0, data shifted on rising edge of SCK, data clocked on falling edge of SCK, A7 = 1)

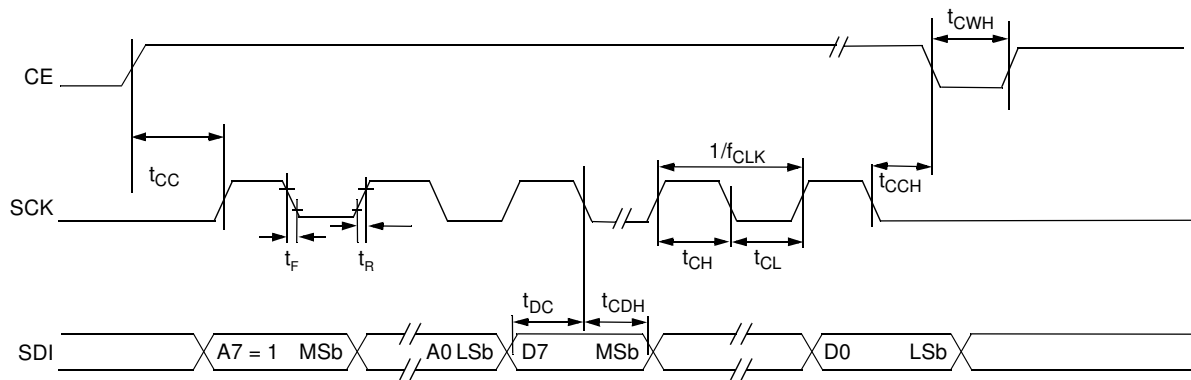

Note: The timing diagram is drawn with CP = 0. The TC72 also functions with CP = 1; however, the edges of SCK are reversed as defined in [Table 4-3](#) and [Figure 4-2](#).

FIGURE 1-1: Serial Port Timing Diagrams.

TC72

NOTES:

2.0 TYPICAL PERFORMANCE CURVES

Note: The graphs and tables provided following this note are a statistical summary based on a limited number of samples and are provided for informational purposes only. The performance characteristics listed herein are not tested or guaranteed. In some graphs or tables, the data presented may be outside the specified operating range (e.g., outside specified power supply range) and therefore outside the warranted range.

Note: Unless otherwise indicated, all parameters apply at $V_{DD} = 2.65V$ to $5.5V$, $T_A = -55^\circ C$ to $+125^\circ C$.

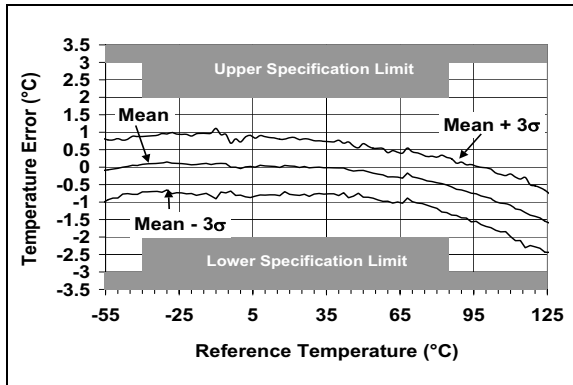

FIGURE 2-1: Accuracy vs. Temperature (TC72-X.XMXX).

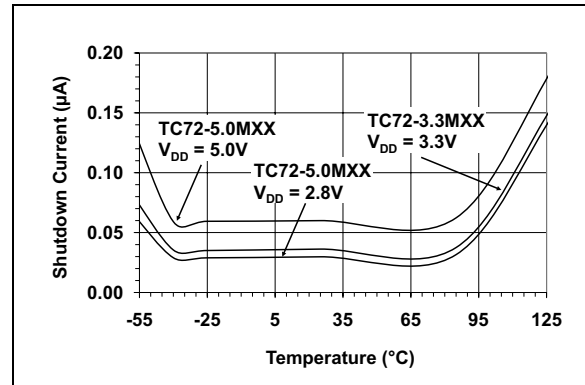

FIGURE 2-4: Shutdown Current vs. Temperature.

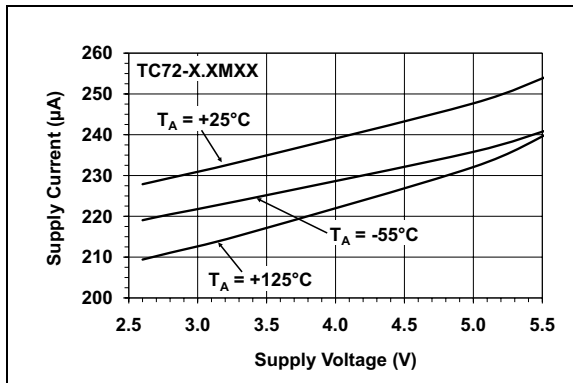

FIGURE 2-2: Supply Current vs. Supply Voltage.

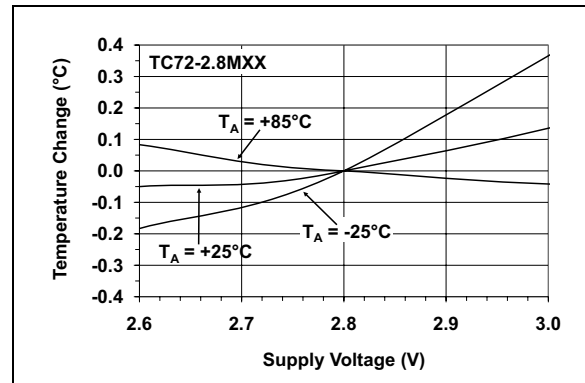

FIGURE 2-5: Temperature Accuracy vs. Supply Voltage (TC72-2.8MXX).

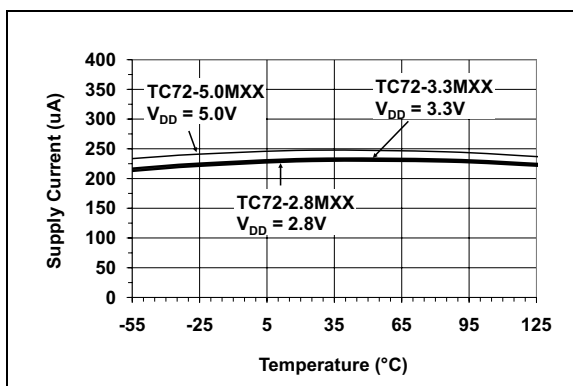

FIGURE 2-3: Supply Current vs. Temperature.

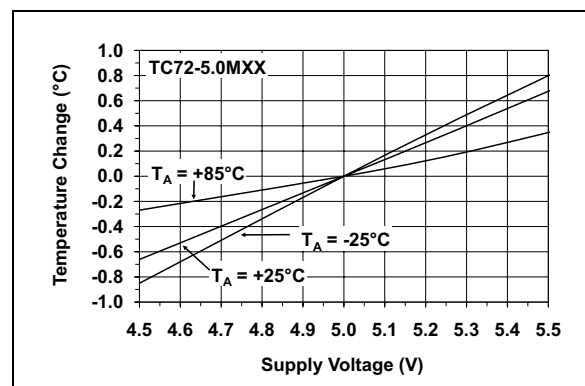

FIGURE 2-6: Temperature Accuracy vs. Supply Voltage (TC72-5.0MXX).

TC72

Note: Unless otherwise indicated, all parameters apply at $V_{DD} = 2.65V$ to $5.5V$, $T_A = -55^{\circ}C$ to $+125^{\circ}C$.

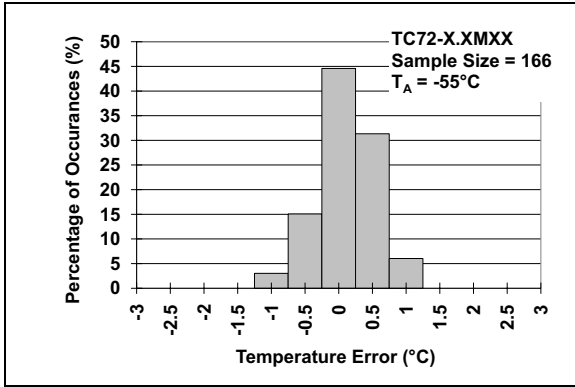

FIGURE 2-7: Histogram of Temperature Accuracy at -55 Degrees C.

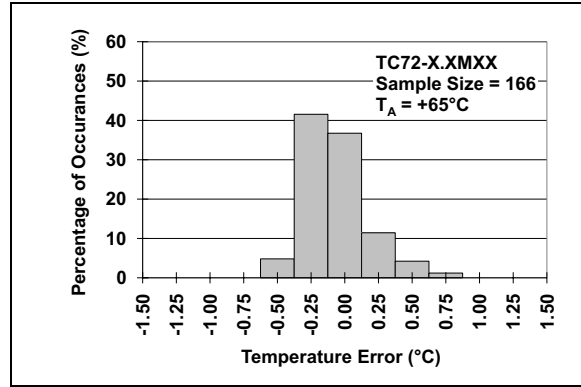

FIGURE 2-10: Histogram of Temperature Accuracy at +65 Degrees C.

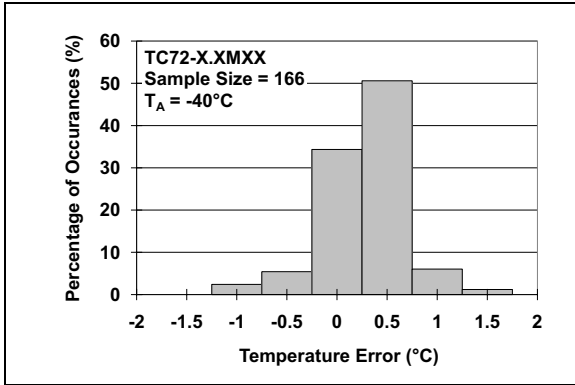

FIGURE 2-8: Histogram of Temperature Accuracy at -40 Degrees C.

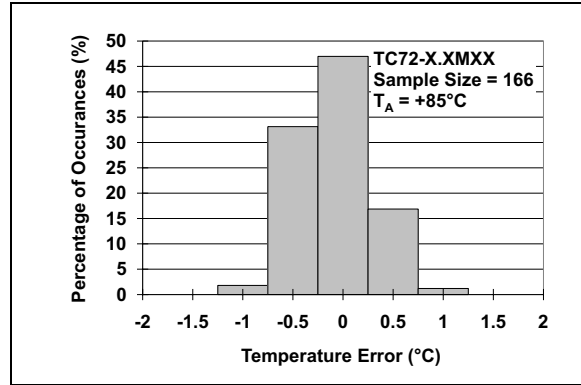

FIGURE 2-11: Histogram of Temperature Accuracy at +85 Degrees C.

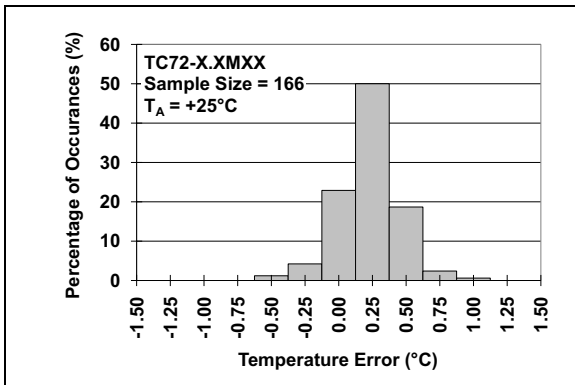

FIGURE 2-9: Histogram of Temperature Accuracy at +25 Degrees C.

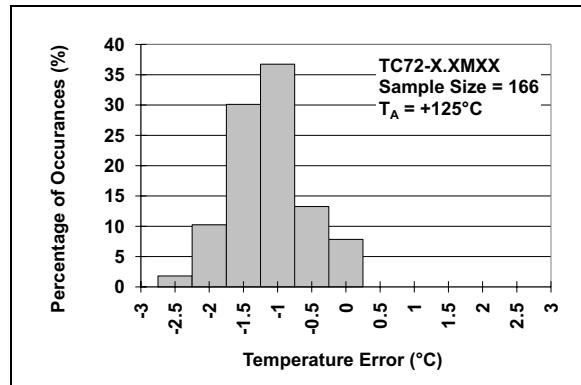

FIGURE 2-12: Histogram of Temperature Accuracy at +125 Degrees C.

3.0 PIN DESCRIPTION

Pin functionalities are described in [Table 3-1](#).

TABLE 3-1: PIN FUNCTION TABLE

TC72		Symbol	Function
3x3 DFN	MSOP		
1	1	NC	No internal connection
2	3	SCK	Serial Clock input
3	2	CE	Chip Enable input, the device is selected when this input is high
4	4	GND	Ground
5	6	SDI	Serial Data input
6	5	SDO	Serial Data output
7	7	NC	No internal connection
8	8	V _{DD}	Power supply
9	—	EP	Exposed pad (Ground)

3.1 No Connection (NC)

This pin is not internally connected to the die.

3.2 Serial Clock Input (SCK)

The SCK pin is an Input pin. All communication and timing is relative to the signal on this pin. The clock is generated by the host controller on the SPI bus (see [Section 4.3 “Serial Bus Interface”](#)).

3.3 Chip Enable Input (CE)

The CE is a Chip Enable pin. This is an active high input, therefore the device is enabled when CE is toggled to V_{DD}. Once the device is enabled, all serial communication begins (see [Section 4.3 “Serial Bus Interface”](#)).

3.4 Ground (GND)

The GND is the system Ground pin.

3.5 Serial Data Input (SDI)

The SDI is a Data Input pin, used to transmit data from the host to the device (see [Section 4.3 “Serial Bus Interface”](#)).

3.6 Serial Data Output (SDO)

The SDO is a Data Output pin, used to transmit data from the device to the host (see [Section 4.3 “Serial Bus Interface”](#)).

3.7 Power Supply (V_{DD})

V_{DD} is the Power pin. The operating voltage range, as specified in the DC electrical specification table, is applied on this pin.

3.8 Exposed Pad (EP)

There is an internal electrical connection between the Exposed Thermal Pad (EP) and the GND pin; they can be connected to the same potential on the Printed Circuit Board (PCB). This provides better thermal conduction from the PCB to the die.

TC72

NOTES:

4.0 FUNCTIONAL DESCRIPTION

TC72 consists of a band-gap type temperature sensor, a 10-bit Sigma Delta Analog-to-Digital Converter (ADC), an internal conversion oscillator and a double buffer digital output port. The 10-bit ADC is scaled from -128°C to $+127^{\circ}\text{C}$; therefore, the resolution is 0.25°C per bit. The ambient temperature operating range of the TC72 is specified from -55°C to $+125^{\circ}\text{C}$.

This device features a four-wire serial interface that is fully compatible with the SPI specification and, therefore, allows simple communications with common microcontrollers and processors. TC72 can be used either in a Continuous Temperature Conversion mode or a One-Shot Conversion mode. TC72 temperature measurements are performed in the background and, therefore, reading the temperature via the serial I/O lines does not affect the measurement in progress.

The Continuous Conversion mode measures the temperature approximately every 150 ms and stores the data in the temperature registers. TC72 has an internal clock generator that controls the automatic temperature conversion sequence. The automatic temperature sampling operation is repeated indefinitely until TC72 is placed in Shutdown mode by a write operation to the Control register. TC72 will remain in Shutdown mode until the shutdown bit in the Control register is reset.

In contrast, the One-Shot mode performs a single temperature measurement and returns to the power-saving shut down mode. This mode is especially useful for low power applications.

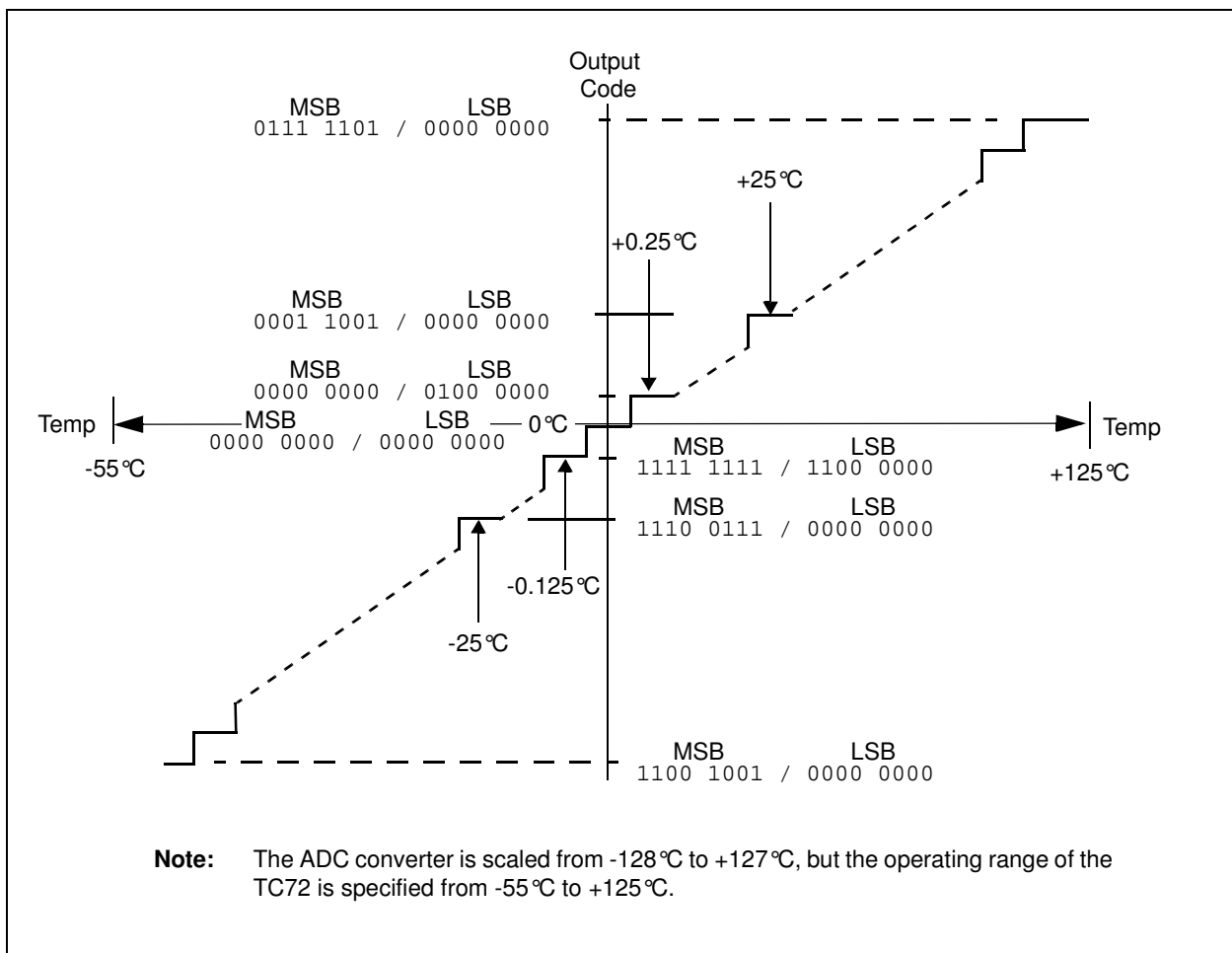

FIGURE 4-1: Temperature-To-Digital Transfer Function (Non-Linear Scale).

4.1 Temperature Data Format

Temperature data is represented by a 10-bit two's complement word with a resolution of 0.25°C per bit. The temperature data is stored in the Temperature registers in a two's complement format. The ADC converter is scaled from -128°C to +127°C, but the operating range of TC72 is specified from -55°C to +125°C.

EXAMPLE 4-1:

Temperature	=	+41.5°C
MSB Temperature Register	=	00101001b
	=	$2^5 + 2^3 + 2^0$
	=	32 + 8 + 1 = 41
LSB Temperature Register	=	10000000b = $2^{-1} = 0.5$

TABLE 4-1: TC72 TEMPERATURE OUTPUT DATA

Temperature	Binary MSB / LSB	Hex
+125°C	0111 1101/0000 0000	7D00
+25°C	0001 1001/0000 0000	1900
+0.5°C	0000 0000/1000 0000	0080
+0.25°C	0000 0000/0100 0000	0040
0°C	0000 0000/0000 0000	0000
-0.25°C	1111 1111/1100 0000	FFC0
-25°C	1110 0111/0000 0000	E700
-55°C	1100 1001/0000 0000	C900

TABLE 4-2: TEMPERATURE REGISTER

D7	D6	D5	D4	D3	D2	D1	D0	Address/ Register
Sign	2^6	2^5	2^4	2^3	2^3	2^1	2^0	02H Temp. MSB
2^{-1}	2^{-2}	0	0	0	0	0	0	01H Temp. LSB

4.2 Power-Up And Power-Down

TC72 is in low-power consumption Shutdown mode at power-up. The Continuous Temperature Conversion mode is selected by performing a Write operation to the Control register, as described in [Section 5.0 "Internal Register Structure"](#).

A supply voltage lower than 1.6V (typical) is considered a power-down state for TC72. If the supply voltage drops below the 1.6V threshold, the internal registers are reset to the power-up default state.

4.3 Serial Bus Interface

The serial interface consists of the Chip Enable (CE), Serial Clock (SCK), Serial Data Input (SDI) and Serial Data Output (SDO) signals. TC72 operates as a slave and is compatible with the SPI bus specifications. The serial interface is designed to be compatible with the Microchip PIC® family of microcontrollers.

The CE input is used to select TC72 when multiple devices are connected to the serial clock and data lines. The CE is active-high, and data is written to or read from the device, when CE is equal to a logic high voltage. The SCK input is disabled when CE is low. The rising edge of the CE line initiates a read or write operation, while the falling edge of CE completes a read or write operation.

The SCK input is provided by the external microcontroller and is used to synchronize the data on the SDI and SDO lines. The SDI input writes data into TC72's Control register, while the SDO outputs the temperature data from the Temperature register and the status of Shutdown bit of the Control register.

TC72 has the capability to function with either an active-high or low SCK input. The SCK inactive state is detected when the CE signal goes high, while the polarity of the clock input (CP) determines whether the data is clocked and shifted on either the rising or falling edge of the system clock, as shown in [Figure 4-2](#). [Table 4-3](#) gives the appropriate clock edge used to transfer data into and out of the registers. Each data bit is transferred at each clock pulse, and the data bits are clocked in groups of eight bits, as shown in [Figure 4-3](#).

The address byte is transferred first, followed by the data. A7, the MSb of the address, determines whether a read or write operation will occur. If A7 = '0', one or more read cycles will occur; otherwise, if A7 = '1', one or more write cycles will occur.

Data can be transferred either in a single byte or a multi-byte packet, as shown in [Figure 4-3](#). In the 3-byte packet, the data sequence consists of the MSb temperature data, LSb temperature data, followed by the Control register data. The multi-byte read feature is initiated by writing the highest address of the desired packet to registers. TC72 will automatically send the register addressed and all of the lower address registers, as long as the Chip Enable pin is held active.

TABLE 4-3: OPERATIONAL MODES

Mode	CE	SCK (Note 1)	SDI	SDO
Disable	L	Input Disabled	Input Disabled	High Z
Write (A7 = 1)	H	CP=1, Data Shifted on Falling Edge, Data Clocked on Rising Edge	Data Bit Latch	High Z
		CP=0, Data Shifted on Rising Edge, Data Clocked on Falling Edge		
Read (A7 = 0)	H	CP=1, Data Shifted on Falling Edge, Data Clocked on Rising Edge	X	Next data bit shift, Note 2
		CP=0, Data Shifted on Rising Edge, Data Clocked on Falling Edge		

- Note 1:** CP is the Clock Polarity of the microcontroller system clock. If the inactive state of SCK is logic level high, CP is equal to '1'; otherwise, if the inactive state of SCK is low, CP is equal to '0'.
- 2:** During a Read operation, SDO remains at a high impedance (High Z) level until the eight bits of data begin to be shifted out of the Temperature register.

4.4 Read Operation

The TC72 uses the CE, SCK and SDO lines to output the Temperature and Control register data. [Figure 4-3](#) shows a timing diagram of the read operation. Communication is initiated by the chip enable (CE) going high. The SDO line remains at the voltage level of the LSb bit that is output and goes to the tri-state level when the CE line goes to a logic low level.

4.5 Write Operation

Data is clocked into the Control register in order to enable TC72's power saving shutdown mode. The write operation is shown in [Figure 4-3](#) and is accomplished using the CE, SCK and SDI lines.

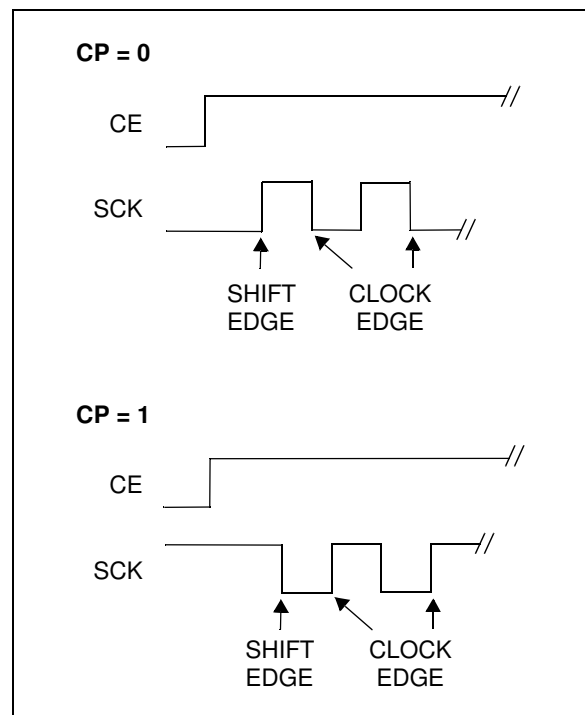
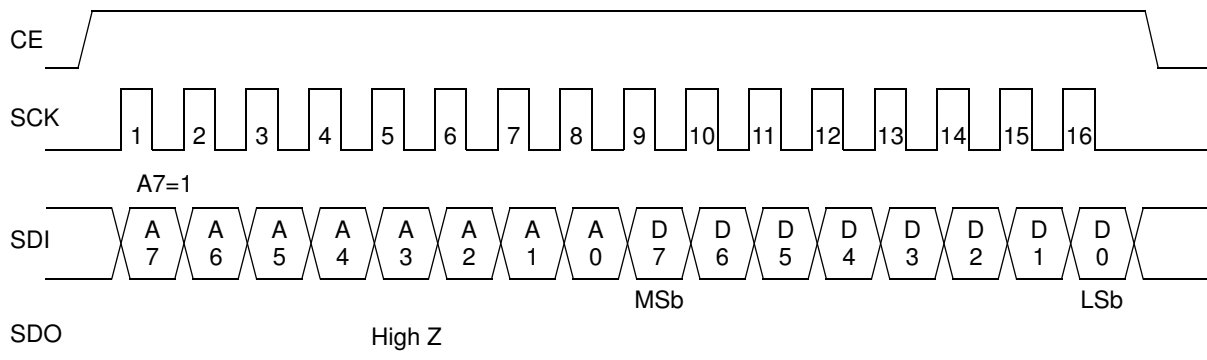

FIGURE 4-2: Serial Clock Polarity (CP) Operation.

Single Byte Write Operation

(CP=0, data shifted on rising edge of SCK, data clocked on falling edge of SCK, A7=1)



Single Byte Read Operation

(CP=0, data shifted on rising edge of SCK, data clocked on falling edge of SCK, A7=0)

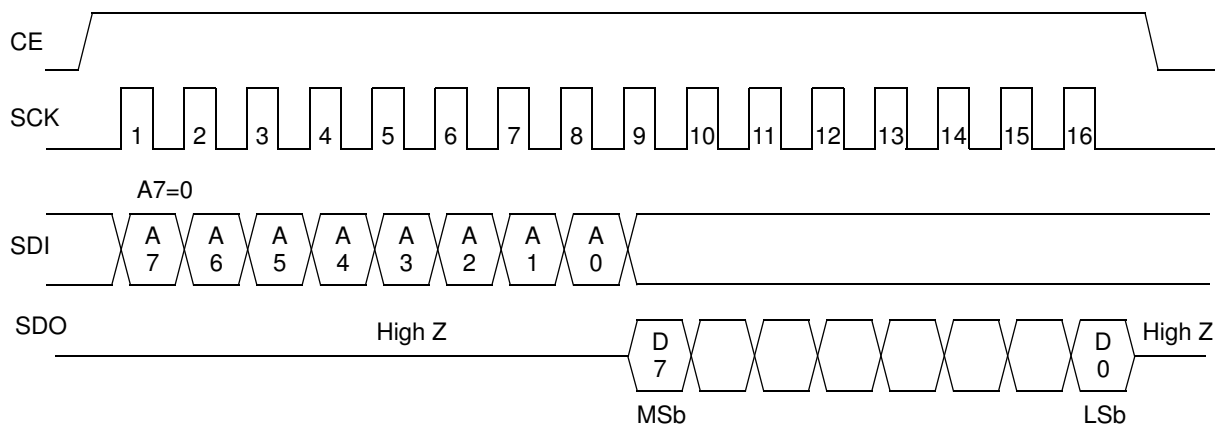

SPI Multiple Byte Transfer

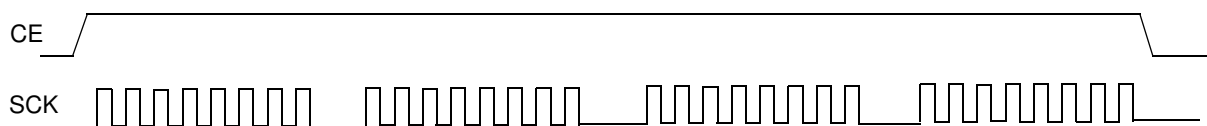

Write Operation

(CP=0, data shifted on rising edge of SCK, data clocked on falling edge of SCK, A7=1)

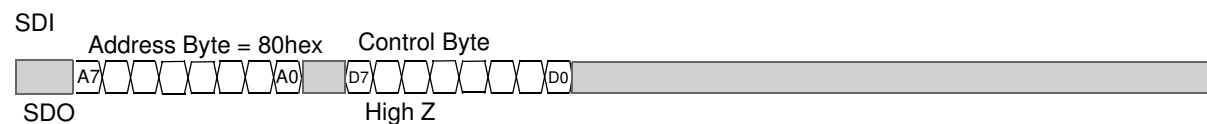

Read Operation

(CP=0, data shifted on rising edge of SCK, data clocked on falling edge of SCK, A7=0)



FIGURE 4-3: Serial Interface Timing Diagrams (CP=0).

5.0 INTERNAL REGISTER STRUCTURE

TC72 registers are listed below.

TABLE 5-1: REGISTERS FOR TC72

Register	Read Address	Write Address	Bit 7	Bit 6	Bit 5	Bit 4	Bit 3	Bit 2	Bit 1	Bit 0	Value on POR/BOR
Control	00hex	80hex	0	0	0	One-Shot (OS)	0	1	0	Shutdown (SHDN)	05hex
LSB Temperature	01hex	N/A	T1	T0	0	0	0	0	0	0	00hex
MSB Temperature	02hex	N/A	T9	T8	T7	T6	T5	T4	T3	T2	00hex
Manufacturer ID	03hex	N/A	0	1	0	1	0	1	0	0	54hex

5.1 Control Register

The Control register is both a read and a write register that is used to select either the Shutdown, Continuous or One-Shot Conversion operating mode. The Temperature Conversion mode selection logic is shown in [Table 5-2](#). The Shutdown (SHDN) bit is stored in bit 0 of the Control register. If SHDN is equal to '1', TC72 will go into power-saving Shutdown mode. If SHDN is equal to '0', TC72 will perform a temperature conversion approximately every 150 ms.

At power-up, the SHDN bit is set to '1'. Thus, TC72 is in Shutdown operating mode at startup. Continuous Temperature Conversion mode is selected by writing a '0' to the SHDN bit of the Control register.

Shutdown mode can be used to minimize the power consumption of TC72 when active temperature monitoring is not required. The Shutdown mode disables the temperature conversion circuitry; however, the serial I/O communication port remains active. A temperature conversion will be initialized by a Write operation to the Control register to select either the Continuous Temperature Conversion or the One-Shot operating mode. The temperature data will be available in the MSB and LSB Temperature registers approximately 150 ms after the Control register Write operation.

One-Shot mode is selected by writing a '1' into bit 4 of the Control register. The One-Shot mode performs a single temperature measurement and returns to the power-saving Shutdown mode. After completion of the temperature conversion, the One-Shot bit (OS) is reset to '0' (i.e. "OFF"). The user must set the One-Shot bit to '1' to initiate another temperature conversion.

Bits 1, 3, 5, 6 and 7 of the Control register are not used by TC72. Bit 2 is set to a logic '1'. Any write operation to these bit locations will have no effect on the operation of TC72.

5.2 Temperature Register

The Temperature register is a read-only register and contains a 10-bit two's complement representation of the temperature measurement. Bit 0 through Bit 5 of the LSB Temperature register are always set to a logic '0'.

At Power-On Reset (POR) or a Brown-Out Reset (BOR) low voltage occurrence, the temperature register is reset to all zeroes, which corresponds to a temperature value of 0°C. A V_{DD} power supply less than 1.6V is considered a reset event and will reset the Temperature register to the power-up state.

5.3 Manufacturer ID Register

The Manufacturer Identification (ID) register is a read-only register used to identify the temperature sensor as a Microchip component.

TABLE 5-2: CONTROL REGISTER TEMPERATURE CONVERSION MODE SELECTION

Operational Mode	One-Shot (OS) Bit 4	Shutdown (SHDN) Bit 0
Continuous Temperature Conversion	0	0
Shutdown	0	1
Continuous Temperature Conversion (One-Shot Command is ignored if SHDN = '0')	1	0
One-Shot	1	1

TC72

NOTES:

6.0 APPLICATIONS INFORMATION

The TC72 does not require any additional components in order to measure temperature; however, it is recommended that a decoupling capacitor of 0.1mF to 1mF be provided between the V_{DD} and GND pins. Although the current consumption of the TC72 is modest (250 mA, typical), the TC72 contains an on chip data acquisition with internal digital switching circuitry. Thus, it is considered good design practice to use an external decoupling capacitor with the sensor. A high frequency ceramic capacitor should be used and be located as close as possible to the IC power pins in order to provide effective noise protection to the TC72.

The TC72 measures temperature by monitoring the voltage of a diode located on the IC die. The IC pins of the TC72 provide a low impedance thermal path between the die and the PCB, allowing the TC72 to effectively monitor the temperature of the PCB board. The thermal path between the ambient air is not as efficient because the plastic IC housing package functions as a thermal insulator. Thus, the ambient air temperature (assuming that a large temperature gradient exists between the air and PCB) has only a small effect on the temperature measured by the TC72.

Note that the exposed metal center pad on the bottom of the DFN package is connected to the silicon substrate. The center pad should be connected to either the PCB ground plane or treated as a “No Connect” pin. The mechanical dimensions of the center pad are given in [Section 7.0 “Packaging Information”](#) of this data sheet.

A potential for self-heating errors can exist if the TC72 SPI communication lines are heavily loaded. Typically, the self-heating error is negligible because of the relatively small current consumption of the TC72. A temperature accuracy error of approximately +0.5°C will result from self-heating if the SPI communication pins sink/source the maximum current specified for the TC72. Thus, to maximize temperature accuracy, the output loading of the SPI signals should be minimized.

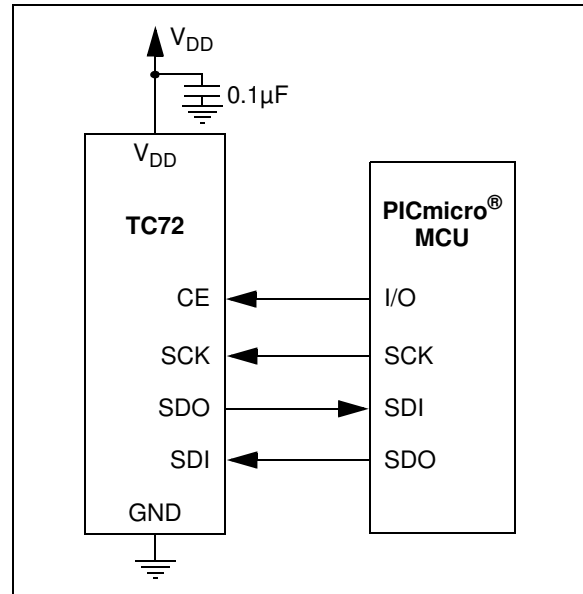

FIGURE 6-1: Typical Application.

TC72

7.0 PACKAGING INFORMATION

7.1 Package Marking Information

8-Lead MSOP

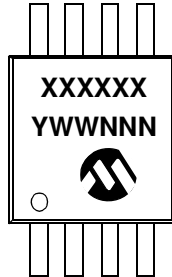

Example:

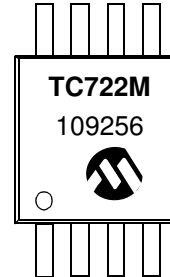

8-Lead DFN

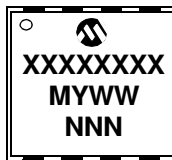

Example:

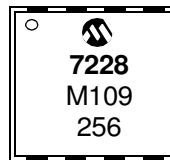

Legend:	XX...X	Customer-specific information
	Y	Year code (last digit of calendar year)
	YY	Year code (last 2 digits of calendar year)
	WW	Week code (week of January 1 is week '01')
	NNN	Alphanumeric traceability code
	(e3)	Pb-free JEDEC designator for Matte Tin (Sn)
	*	This package is Pb-free. The Pb-free JEDEC designator (e3) can be found on the outer packaging for this package.

Note: In the event the full Microchip part number cannot be marked on one line, it will be carried over to the next line, thus limiting the number of available characters for customer-specific information.

8-Lead Plastic Micro Small Outline Package (MS) [MSOP]

Note: For the most current package drawings, please see the Microchip Packaging Specification located at <http://www.microchip.com/packaging>

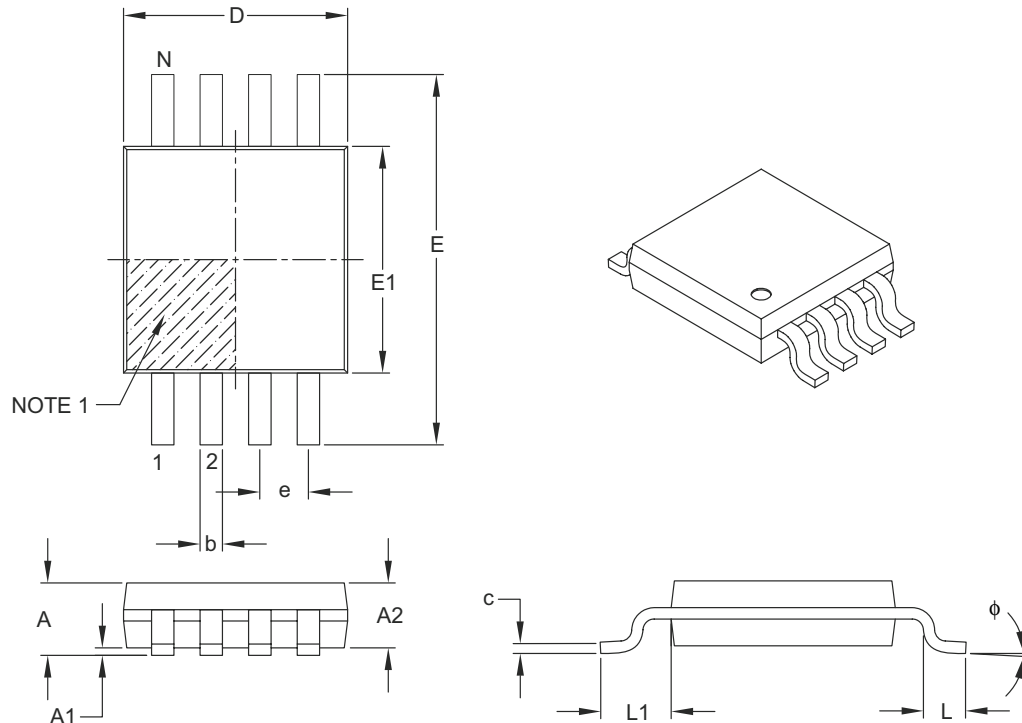

Dimension	Units	MILLIMETERS		
		MIN	NOM	MAX
Number of Pins	N	8		
Pitch	e	0.65 BSC		
Overall Height	A	–	–	1.10
Molded Package Thickness	A2	0.75	0.85	0.95
Standoff	A1	0.00	–	0.15
Overall Width	E	4.90 BSC		
Molded Package Width	E1	3.00 BSC		
Overall Length	D	3.00 BSC		
Foot Length	L	0.40	0.60	0.80
Footprint	L1	0.95 REF		
Foot Angle	ϕ	0°	–	8°
Lead Thickness	c	0.08	–	0.23
Lead Width	b	0.22	–	0.40

Notes:

- Pin 1 visual index feature may vary, but must be located within the hatched area.
- Dimensions D and E1 do not include mold flash or protrusions. Mold flash or protrusions shall not exceed 0.15 mm per side.
- Dimensioning and tolerancing per ASME Y14.5M.

BSC: Basic Dimension. Theoretically exact value shown without tolerances.

REF: Reference Dimension, usually without tolerance, for information purposes only.

Microchip Technology Drawing C04-111B

8-Lead Plastic Dual Flat, No Lead Package (MF) - 3x3x0.9mm Body [DFN]

Note: For the most current package drawings, please see the Microchip Packaging Specification located at <http://www.microchip.com/packaging>

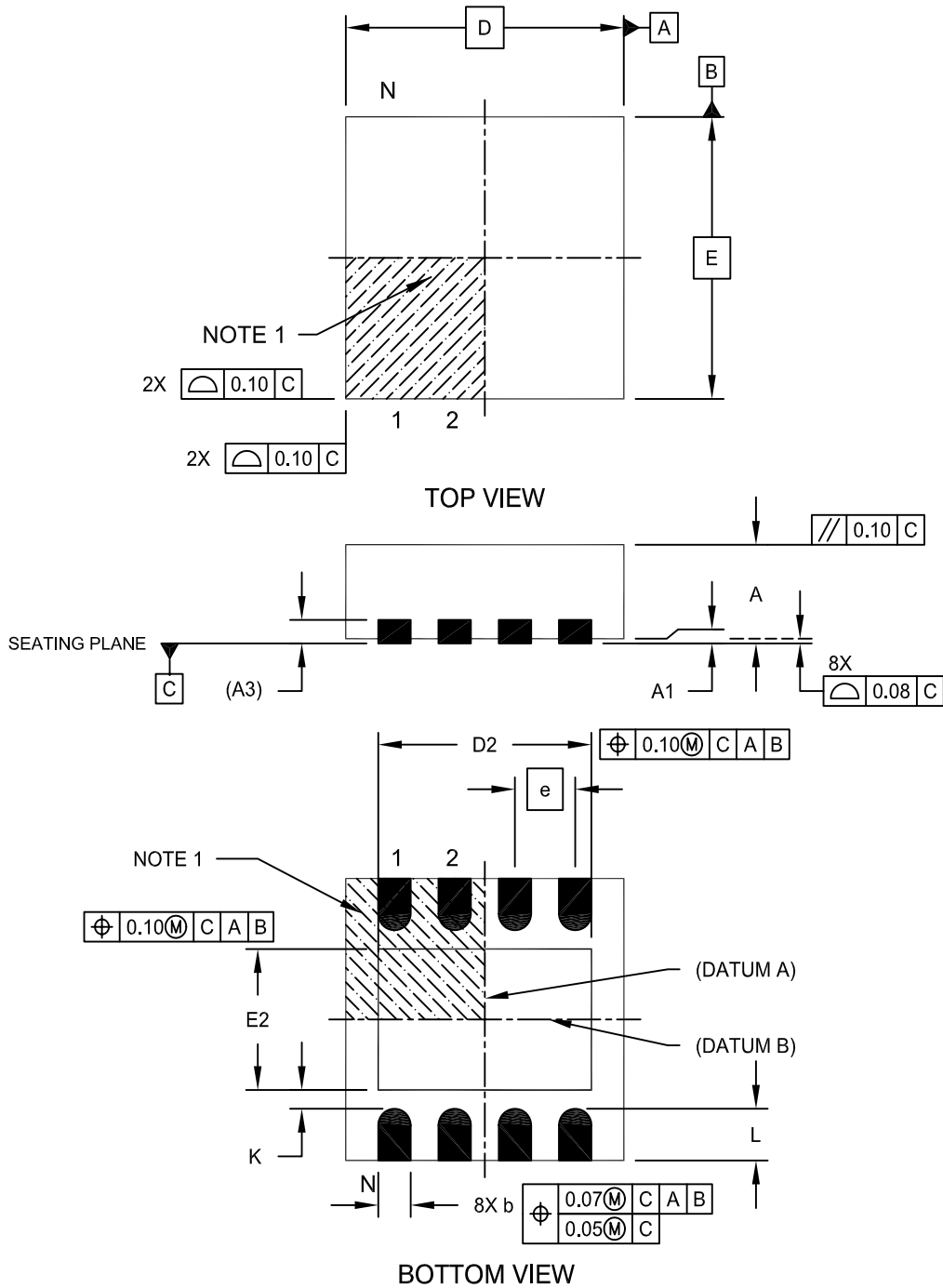

Microchip Technology Drawing No. C04-062C Sheet 1 of 2

8-Lead Plastic Dual Flat, No Lead Package (MF) - 3x3x0.9mm Body [DFN]

Note: For the most current package drawings, please see the Microchip Packaging Specification located at <http://www.microchip.com/packaging>

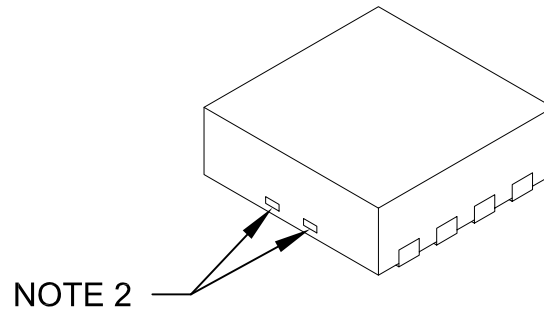

Dimension	Units	MILLIMETERS		
		MIN	NOM	MAX
Number of Pins	N	8		
Pitch	e	0.65 BSC		
Overall Height	A	0.80	0.90	1.00
Standoff	A1	0.00	0.02	0.05
Contact Thickness	A3	0.20 REF		
Overall Length	D	3.00 BSC		
Exposed Pad Width	E2	1.34	-	1.60
Overall Width	E	3.00 BSC		
Exposed Pad Length	D2	1.60	-	2.40
Contact Width	b	0.25	0.30	0.35
Contact Length	L	0.20	0.30	0.55
Contact-to-Exposed Pad	K	0.20	-	-

Notes:

1. Pin 1 visual index feature may vary, but must be located within the hatched area.
2. Package may have one or more exposed tie bars at ends.
3. Package is saw singulated
4. Dimensioning and tolerancing per ASME Y14.5M

BSC: Basic Dimension. Theoretically exact value shown without tolerances.

REF: Reference Dimension, usually without tolerance, for information purposes only.

Microchip Technology Drawing No. C04-062C Sheet 2 of 2

8-Lead Plastic Dual Flat, No Lead Package (MF) – 3x3x0.9 mm Body [DFN]

Note: For the most current package drawings, please see the Microchip Packaging Specification located at <http://www.microchip.com/packaging>

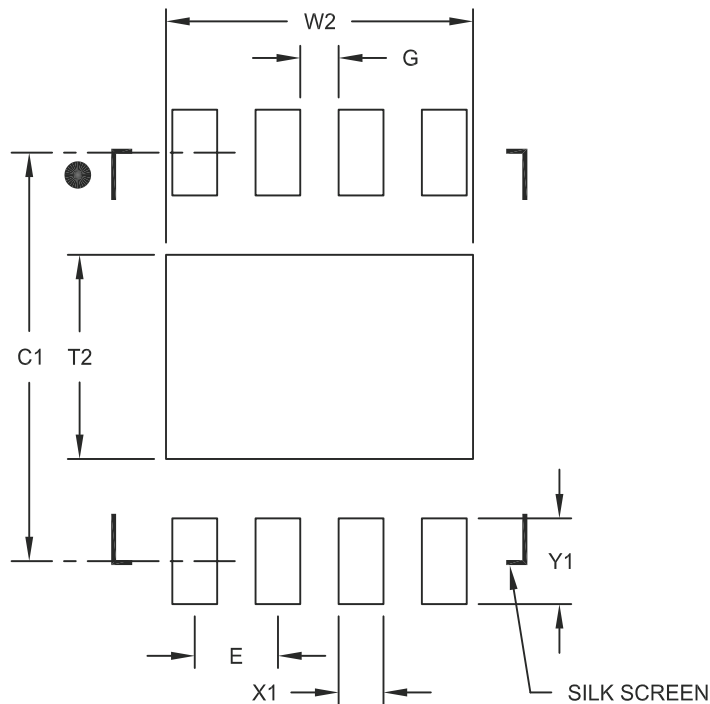

RECOMMENDED LAND PATTERN

Units		MILLIMETERS		
Dimension Limits		MIN	NOM	MAX
Contact Pitch	E	0.65 BSC		
Optional Center Pad Width	W2			2.40
Optional Center Pad Length	T2			1.55
Contact Pad Spacing	C1		3.10	
Contact Pad Width (X8)	X1			0.35
Contact Pad Length (X8)	Y1			0.65
Distance Between Pads	G	0.30		

Notes:

1. Dimensioning and tolerancing per ASME Y14.5M

BSC: Basic Dimension. Theoretically exact value shown without tolerances.

Microchip Technology Drawing No. C04-2062A

APPENDIX A: REVISION HISTORY

Revision B (July 2011)

The following is the list of modifications:

1. Updated DFN pin drawing.
2. Added new chapter **Section 3.0 “PIN Description”**.
3. Moved Typical Application figure in **Section 6.0 “Applications information”** (see **Figure 6-1**).
4. Updated **Section 7.0 “Packaging Information”**

Revision A (October 2002)

- Original data sheet for the TC72 device.

TC72

NOTES:

PRODUCT IDENTIFICATION SYSTEM

To order or obtain information, e.g., on pricing or delivery, refer to the factory or the listed sales office.

PART NO.	XX	X	/XX
Device	Voltage Range	Temperature Range	Package
<p>Device: TC72: Digital Temperature Sensor w/SPI Interface</p> <p>Voltage Range: 2.8 = Accuracy Optimized for 2.8V 3.3 = Accuracy Optimized for 3.3V 5.0 = Accuracy Optimized for 5.0V</p> <p>Temperature Range: M = -55°C to +125°C</p> <p>Package: MF = Dual, Flat, No Lead (DFN) (3x3mm), 8-lead MFTR = Dual, Flat, No Lead (DFN) (3x3mm), 8-lead (Tape and Reel) UA = Plastic Micro Small Outline (MSOP), 8-lead UATR = Plastic Micro Small Outline (MSOP), 8-lead (Tape and Reel)</p>			
<p>Examples:</p> <p>a) TC72-2.8MUA: Digital Temperature Sensor, 2.8V, 8LD MSOP package.</p> <p>b) TC72-2.8MUATR: Digital Temperature Sensor, 2.8V, 8LD MSOP (tape and reel) package.</p> <p>c) TC72-2.8MMF: Digital Temperature Sensor, 2.8V, 8LD DFN package.</p> <p>d) TC72-3.3MUA: Digital Temperature Sensor, 3.3V, 8LD MSOP package.</p> <p>e) TC72-3.3MMF: Digital Temperature Sensor, 3.3V, 8LD DFN package.</p> <p>f) TC72-5.0MUA: Digital Temperature Sensor, 5.0V, 8LD MSOP package.</p> <p>g) TC72-5.0MMF: Digital Temperature Sensor, 5.0V, 8LD DFN package.</p> <p>h) TC72-5.0MMFTR: Digital Temperature Sensor, 5.0V, 8LD DFN (tape and reel) package.</p>			

TC72

NOTES:

Note the following details of the code protection feature on Microchip devices:

- Microchip products meet the specification contained in their particular Microchip Data Sheet.
- Microchip believes that its family of products is one of the most secure families of its kind on the market today, when used in the intended manner and under normal conditions.
- There are dishonest and possibly illegal methods used to breach the code protection feature. All of these methods, to our knowledge, require using the Microchip products in a manner outside the operating specifications contained in Microchip's Data Sheets. Most likely, the person doing so is engaged in theft of intellectual property.
- Microchip is willing to work with the customer who is concerned about the integrity of their code.
- Neither Microchip nor any other semiconductor manufacturer can guarantee the security of their code. Code protection does not mean that we are guaranteeing the product as “unbreakable.”

Code protection is constantly evolving. We at Microchip are committed to continuously improving the code protection features of our products. Attempts to break Microchip's code protection feature may be a violation of the Digital Millennium Copyright Act. If such acts allow unauthorized access to your software or other copyrighted work, you may have a right to sue for relief under that Act.

Information contained in this publication regarding device applications and the like is provided only for your convenience and may be superseded by updates. It is your responsibility to ensure that your application meets with your specifications. MICROCHIP MAKES NO REPRESENTATIONS OR WARRANTIES OF ANY KIND WHETHER EXPRESS OR IMPLIED, WRITTEN OR ORAL, STATUTORY OR OTHERWISE, RELATED TO THE INFORMATION, INCLUDING BUT NOT LIMITED TO ITS CONDITION, QUALITY, PERFORMANCE, MERCHANTABILITY OR FITNESS FOR PURPOSE. Microchip disclaims all liability arising from this information and its use. Use of Microchip devices in life support and/or safety applications is entirely at the buyer's risk, and the buyer agrees to defend, indemnify and hold harmless Microchip from any and all damages, claims, suits, or expenses resulting from such use. No licenses are conveyed, implicitly or otherwise, under any Microchip intellectual property rights.

Trademarks

The Microchip name and logo, the Microchip logo, dsPIC, KEELOQ, KEELOQ logo, MPLAB, PIC, PICmicro, PICSTART, PIC³² logo, rfPIC and UNI/O are registered trademarks of Microchip Technology Incorporated in the U.S.A. and other countries.

FilterLab, Hampshire, HI-TECH C, Linear Active Thermistor, MXDEV, MXLAB, SEEVAL and The Embedded Control Solutions Company are registered trademarks of Microchip Technology Incorporated in the U.S.A.

Analog-for-the-Digital Age, Application Maestro, chipKIT, chipKIT logo, CodeGuard, dsPICDEM, dsPICDEM.net, dsPICworks, dsSPEAK, ECAN, ECONOMONITOR, FanSense, HI-TIDE, In-Circuit Serial Programming, ICSP, Mindi, MiWi, MPASM, MPLAB Certified logo, MPLIB, MPLINK, mTouch, Omniscient Code Generation, PICC, PICC-18, PICDEM, PICDEM.net, PICKit, PICtail, REAL ICE, rfLAB, Select Mode, Total Endurance, TSHARC, UniWinDriver, WiperLock and ZENA are trademarks of Microchip Technology Incorporated in the U.S.A. and other countries.

SQTP is a service mark of Microchip Technology Incorporated in the U.S.A.

All other trademarks mentioned herein are property of their respective companies.

© 2011, Microchip Technology Incorporated, Printed in the U.S.A., All Rights Reserved.

 Printed on recycled paper.

ISBN: 978-1-61341-429-3

QUALITY MANAGEMENT SYSTEM
CERTIFIED BY DNV
== ISO/TS 16949:2009 ==

Microchip received ISO/TS-16949:2009 certification for its worldwide headquarters, design and wafer fabrication facilities in Chandler and Tempe, Arizona; Gresham, Oregon and design centers in California and India. The Company's quality system processes and procedures are for its PIC[®] MCUs and dsPIC[®] DSCs, KEELOQ[®] code hopping devices, Serial EEPROMs, microperipherals, nonvolatile memory and analog products. In addition, Microchip's quality system for the design and manufacture of development systems is ISO 9001:2000 certified.



MICROCHIP

Worldwide Sales and Service

AMERICAS

Corporate Office
2355 West Chandler Blvd.
Chandler, AZ 85224-6199
Tel: 480-792-7200
Fax: 480-792-7277
Technical Support:
<http://www.microchip.com/support>
Web Address:
www.microchip.com

Atlanta
Duluth, GA
Tel: 678-957-9614
Fax: 678-957-1455

Boston
Westborough, MA
Tel: 774-760-0087
Fax: 774-760-0088

Chicago
Itasca, IL
Tel: 630-285-0071
Fax: 630-285-0075

Cleveland
Independence, OH
Tel: 216-447-0464
Fax: 216-447-0643

Dallas
Addison, TX
Tel: 972-818-7423
Fax: 972-818-2924

Detroit
Farmington Hills, MI
Tel: 248-538-2250
Fax: 248-538-2260

Indianapolis
Noblesville, IN
Tel: 317-773-8323
Fax: 317-773-5453

Los Angeles
Mission Viejo, CA
Tel: 949-462-9523
Fax: 949-462-9608

Santa Clara
Santa Clara, CA
Tel: 408-961-6444
Fax: 408-961-6445

Toronto
Mississauga, Ontario,
Canada
Tel: 905-673-0699
Fax: 905-673-6509

ASIA/PACIFIC

Asia Pacific Office
Suites 3707-14, 37th Floor
Tower 6, The Gateway
Harbour City, Kowloon
Hong Kong
Tel: 852-2401-1200
Fax: 852-2401-3431

Australia - Sydney
Tel: 61-2-9868-6733
Fax: 61-2-9868-6755

China - Beijing
Tel: 86-10-8569-7000
Fax: 86-10-8528-2104

China - Chengdu
Tel: 86-28-8665-5511
Fax: 86-28-8665-7889

China - Chongqing
Tel: 86-23-8980-9588
Fax: 86-23-8980-9500

China - Hangzhou
Tel: 86-571-2819-3180
Fax: 86-571-2819-3189

China - Hong Kong SAR
Tel: 852-2401-1200
Fax: 852-2401-3431

China - Nanjing
Tel: 86-25-8473-2460
Fax: 86-25-8473-2470

China - Qingdao
Tel: 86-532-8502-7355
Fax: 86-532-8502-7205

China - Shanghai
Tel: 86-21-5407-5533
Fax: 86-21-5407-5066

China - Shenyang
Tel: 86-24-2334-2829
Fax: 86-24-2334-2393

China - Shenzhen
Tel: 86-755-8203-2660
Fax: 86-755-8203-1760

China - Wuhan
Tel: 86-27-5980-5300
Fax: 86-27-5980-5118

China - Xian
Tel: 86-29-8833-7252
Fax: 86-29-8833-7256

China - Xiamen
Tel: 86-592-2388138
Fax: 86-592-2388130

China - Zhuhai
Tel: 86-756-3210040
Fax: 86-756-3210049

ASIA/PACIFIC

India - Bangalore
Tel: 91-80-3090-4444
Fax: 91-80-3090-4123

India - New Delhi
Tel: 91-11-4160-8631
Fax: 91-11-4160-8632

India - Pune
Tel: 91-20-2566-1512
Fax: 91-20-2566-1513

Japan - Yokohama
Tel: 81-45-471- 6166
Fax: 81-45-471-6122

Korea - Daegu
Tel: 82-53-744-4301
Fax: 82-53-744-4302

Korea - Seoul
Tel: 82-2-554-7200
Fax: 82-2-558-5932 or
82-2-558-5934

Malaysia - Kuala Lumpur
Tel: 60-3-6201-9857
Fax: 60-3-6201-9859

Malaysia - Penang
Tel: 60-4-227-8870
Fax: 60-4-227-4068

Philippines - Manila
Tel: 63-2-634-9065
Fax: 63-2-634-9069

Singapore
Tel: 65-6334-8870
Fax: 65-6334-8850

Taiwan - Hsin Chu
Tel: 886-3-6578-300
Fax: 886-3-6578-370

Taiwan - Kaohsiung
Tel: 886-7-213-7830
Fax: 886-7-330-9305

Taiwan - Taipei
Tel: 886-2-2500-6610
Fax: 886-2-2508-0102

Thailand - Bangkok
Tel: 66-2-694-1351
Fax: 66-2-694-1350

EUROPE

Austria - Wels
Tel: 43-7242-2244-39
Fax: 43-7242-2244-393

Denmark - Copenhagen
Tel: 45-4450-2828
Fax: 45-4485-2829

France - Paris
Tel: 33-1-69-53-63-20
Fax: 33-1-69-30-90-79

Germany - Munich
Tel: 49-89-627-144-0
Fax: 49-89-627-144-44

Italy - Milan
Tel: 39-0331-742611
Fax: 39-0331-466781

Netherlands - Drunen
Tel: 31-416-690399
Fax: 31-416-690340

Spain - Madrid
Tel: 34-91-708-08-90
Fax: 34-91-708-08-91

UK - Wokingham
Tel: 44-118-921-5869
Fax: 44-118-921-5820

05/02/11