

## Switched Capacitor Voltage Converters

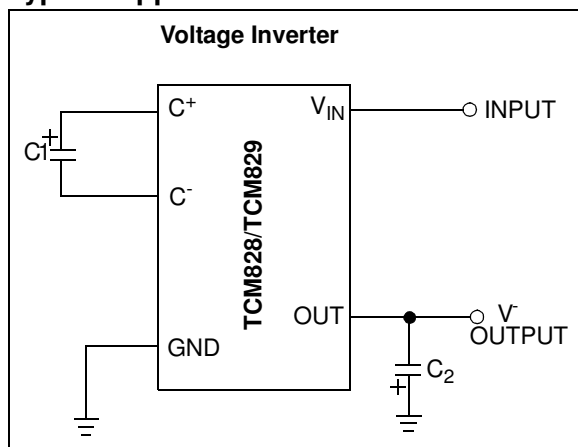
### Features

- Charge Pump in 5-Pin SOT-23 Package
- >95% Voltage Conversion Efficiency
- Voltage Inversion and/or Doubling
- Low 50  $\mu\text{A}$  (TCM828) Quiescent Current
- Operates from +1.5V to +5.5V
- Up to 25 mA Output Current
- Only Two External Capacitors Required

### Applications

- LCD Panel Bias
- Cellular Phones
- Pagers
- PDAs, Portable Dataloggers
- Battery-Powered Devices

### Typical Application Circuit



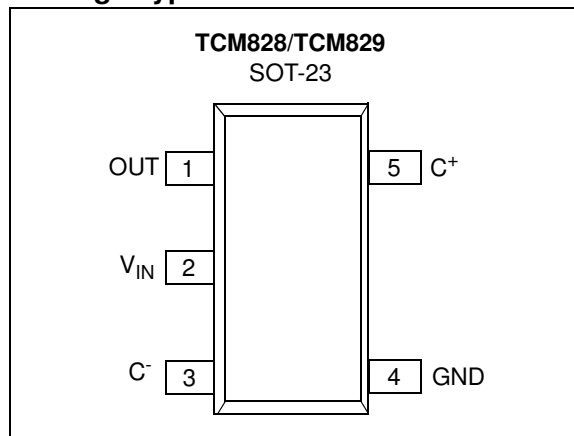
### Description

The TCM828/TCM829 devices are CMOS “charge-pump” voltage converters in ultra-small, 5-Pin SOT-23 packages. They invert and/or double an input voltage which can range from +1.5V to +5.5V. Conversion efficiency is typically >95%. Switching frequency is 12 kHz for the TCM828, and 35 kHz for the TCM829.

External component requirement is only two capacitors (3.3  $\mu\text{F}$  nominal) for standard voltage inverter applications. With a few additional components, a positive doubler can also be built. All other circuitry, including control, oscillator and power MOSFETs, are integrated on-chip. Supply current is 50  $\mu\text{A}$  (TCM828) and 115  $\mu\text{A}$  (TCM829).

The TCM828 and TCM829 devices are available in a 5-Pin SOT-23 surface mount package.

### Package Type



### Ordering Information

Part No.	Package	Temperature Range
TCM828ECT	5-Pin SOT-23	-40 °C to +85 °C
TCM828VT	5-Pin SOT-23	-40 °C to +125 °C
TCM829ECT	5-Pin SOT-23	-40 °C to +85 °C

**Note:** 5-Pin SOT-23 is equivalent to EIAJ SC-74A.

# TCM828/TCM829

---

NOTES:

## 1.0 ELECTRICAL CHARACTERISTICS

### Absolute Maximum Ratings †

Input Voltage ( $V_{IN}$ to GND) .....	+30V
Output Voltage (OUT to GND) .....	6.0V, +0.3V
Current at OUT Pin .....	50 mA
Short-Circuit Duration – OUT to GND .....	Indefinite
Operating Temperature Range .....	-40°C to +85°C
Variable Temp. Range ( <b>TCM828 only</b> ) .....	
.....	-40°C to +125°C
Power Dissipation ( $T_A \leq 70^\circ\text{C}$ ) .....	240 mW
Storage Temperature (Unbiased).....	-65°C to +150°C
Lead Temperature (Soldering, 10 sec).....	+300°C

† **Notice:** Stresses above those listed under “Maximum Ratings” may cause permanent damage to the device. This is a stress rating only and functional operation of the device at those or any other conditions above those indicated in the operational listings of this specification is not implied. Exposure to maximum rating conditions for extended periods may affect device reliability.

### ELECTRICAL CHARACTERISTICS (0 °C TO +85 °C)

**Electrical Specifications:**  $T_A = 0^\circ\text{C}$  to  $+85^\circ\text{C}$ ,  $V_{IN} = +5\text{V}$ ,  $C1 = C2 = 10\ \mu\text{F}$  (TCM828),  $C1 = C2 = 3.3\ \mu\text{F}$  (TCM829), unless otherwise noted. Typical values are at  $T_A = +25^\circ\text{C}$ .

Parameters	Sym	Min	Typ	Max	Units	Conditions
Supply Current	$I_{DD}$	—	50	90	$\mu\text{A}$	<b>TCM828</b> , $T_A = +25^\circ\text{C}$
		—	115	260	$\mu\text{A}$	<b>TCM829</b> , $T_A = +25^\circ\text{C}$
Minimum Supply Voltage	$V^+$	1.5	—	—	V	$R_{LOAD} = 10\ \text{k}\Omega$ , $T_A = 0^\circ\text{C}$ to $+85^\circ\text{C}$
Maximum Supply Voltage	$V^+$	—	—	5.5	V	$R_{LOAD} = 10\ \text{k}\Omega$
Oscillator Frequency	$F_{OSC}$	8.4	12	15.6	kHz	<b>TCM828</b> , $T_A = +25^\circ\text{C}$
		24.5	35	45.5	kHz	<b>TCM829</b> , $T_A = +25^\circ\text{C}$
Power Efficiency	$P_{EFF}$	—	96	—	%	$I_{LOAD} = 3\ \text{mA}$ , $T_A = +25^\circ\text{C}$
Voltage Conversion Efficiency	$V_{EFF}$	95	99.9	—	%	$R_{LOAD} = \infty$
Output Resistance	$R_{OUT}$	—	25	50	$\Omega$	$I_{OUT} = 5\ \text{mA}$ , $T_A = +25^\circ\text{C}$
		—	—	65	$\Omega$	$I_{OUT} = 5\ \text{mA}$ , $T_A = 0^\circ\text{C}$ to $+85^\circ\text{C}$

**Note 1:** Capacitor contribution is approximately 20% of the output impedance [ $ESR = 1/\text{pump frequency} \times \text{capacitance}$ ].

### ELECTRICAL CHARACTERISTICS (-40 °C TO +85 °C)

**Electrical Specifications:**  $T_A = -40^\circ\text{C}$  to  $+85^\circ\text{C}$ ,  $V_{IN} = +5\text{V}$ ,  $C1 = C2 = 10\ \mu\text{F}$  (TCM828),  $C1 = C2 = 3.3\ \mu\text{F}$  (TCM829), unless otherwise noted. Typical values are at  $T_A = +25^\circ\text{C}$ . (**Note 1**)

Parameters	Sym	Min	Typ	Max	Units	Conditions
Supply Current	$I_{DD}$	—	—	115	$\mu\text{A}$	<b>TCM828</b>
		—	—	325	$\mu\text{A}$	<b>TCM829</b>
Supply Voltage Range	$V^+$	1.5	—	5.5	V	$R_{LOAD} = 10\ \text{k}\Omega$
Oscillator Frequency	$F_{OSC}$	6	—	15.6	kHz	<b>TCM828</b>
		19	—	45.5	kHz	<b>TCM829</b>
Output Resistance	$R_{OUT}$	—	—	65	$\Omega$	$I_{OUT} = 5\ \text{mA}$

**Note 1:** All -40°C to +85°C specifications above are assured by design.

# TCM828/TCM829

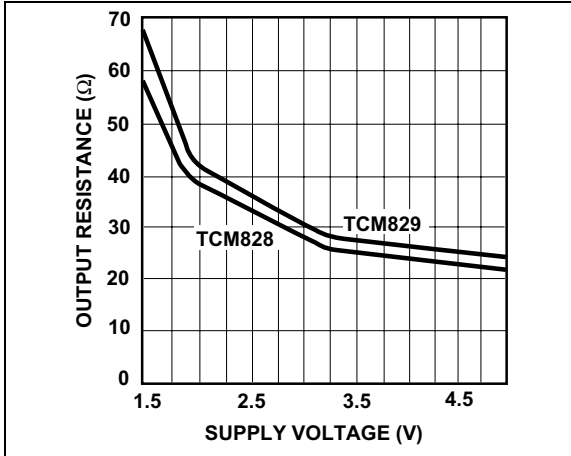
---

NOTES:

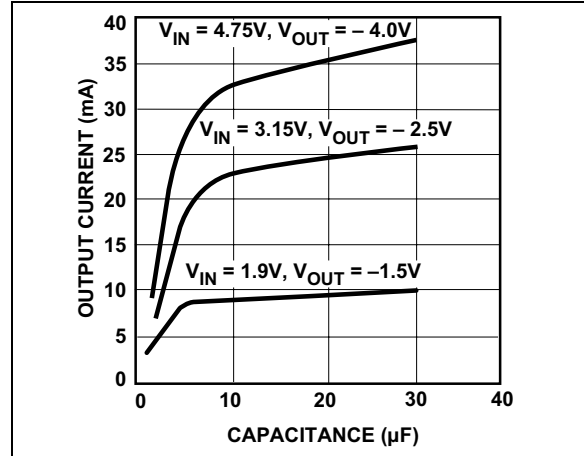
## 2.0 TYPICAL CHARACTERISTICS

**Note:** The graphs and tables provided following this note are a statistical summary based on a limited number of samples and are provided for informational purposes only. The performance characteristics listed herein are not tested or guaranteed. In some graphs or tables, the data presented may be outside the specified operating range (e.g., outside specified power supply range) and therefore outside the warranted range.

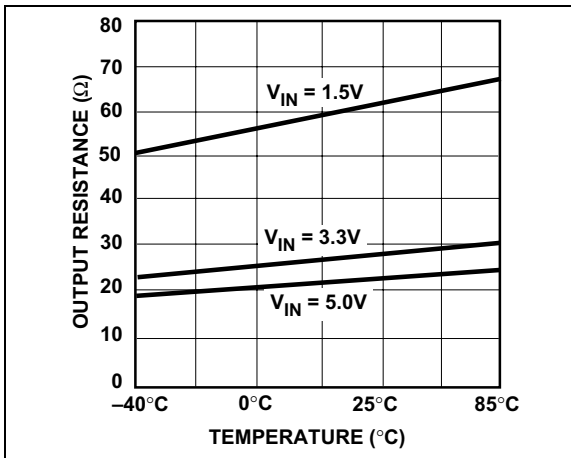
**Note:** Circuit of Figure 5-3,  $V_{IN} = +5V$ ,  $C1 = C2 = C3$ ,  $T_A = +25^\circ C$ , unless otherwise noted.



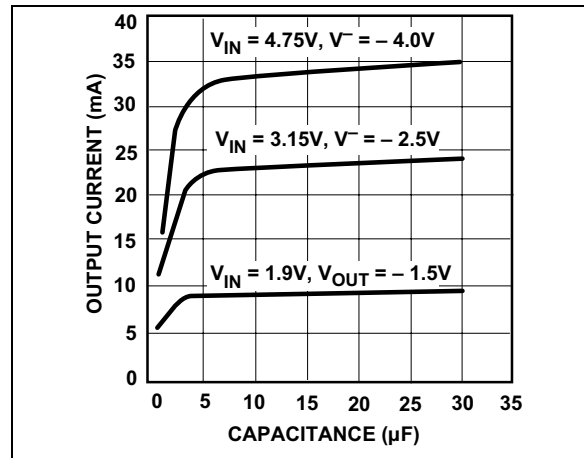
**FIGURE 2-1:** Output Resistance vs. Supply Voltage.



**FIGURE 2-3:** TCM828 – Output Current vs. Capacitance.



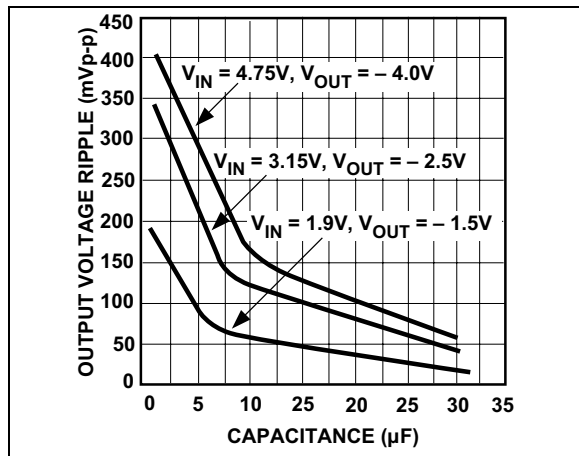
**FIGURE 2-2:** Output Resistance vs. Temperature.



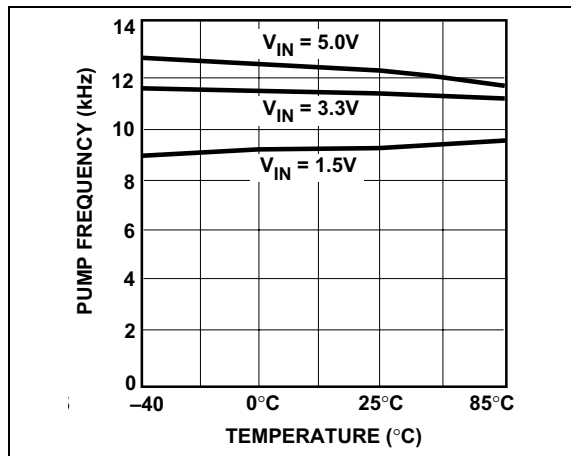
**FIGURE 2-4:** TCM829 – Output Current vs. Capacitance.

# TCM828/TCM829

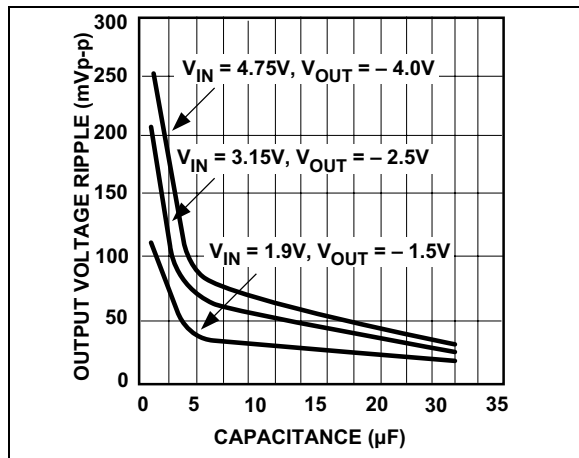
Note: Circuit of Figure 5-3,  $V_{IN} = +5V$ ,  $C1 = C2 = C3$ ,  $T_A = +25^\circ C$ , unless otherwise noted.



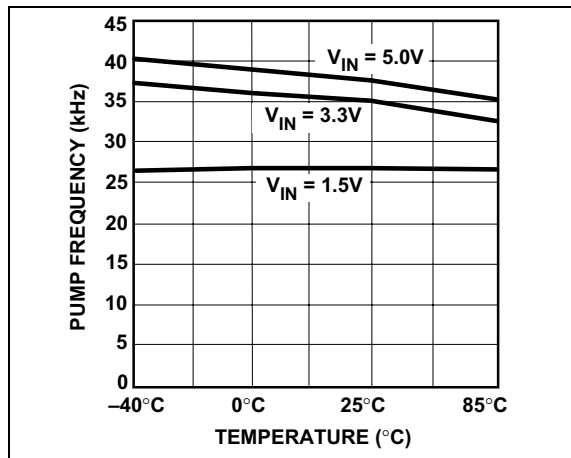
**FIGURE 2-5:** TCM828 – Output Voltage Ripple vs. Capacitance.



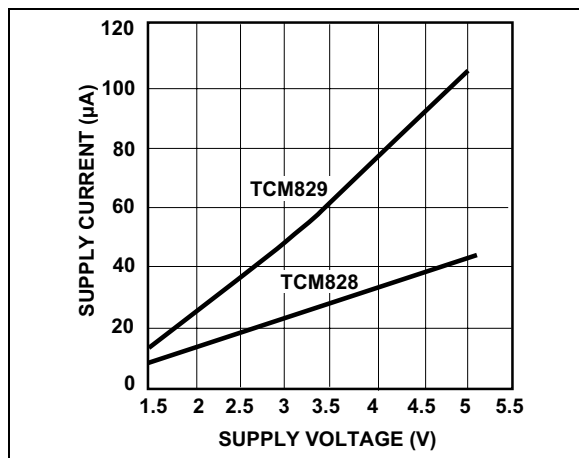
**FIGURE 2-8:** TCM828 – Pump Frequency vs. Temperature.



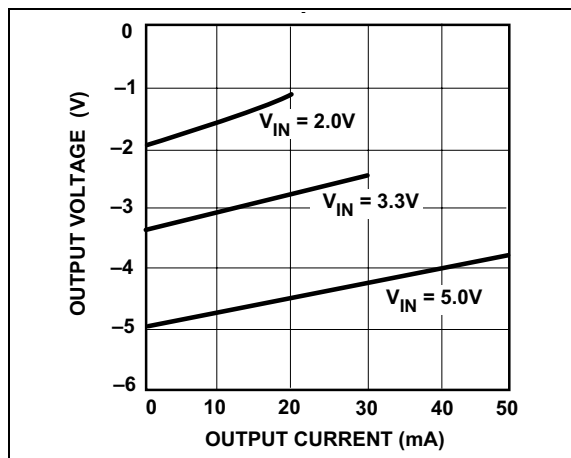
**FIGURE 2-6:** TCM829 – Output Voltage Ripple vs. Capacitance.



**FIGURE 2-9:** TCM829 – Pump Frequency vs. Temperature.

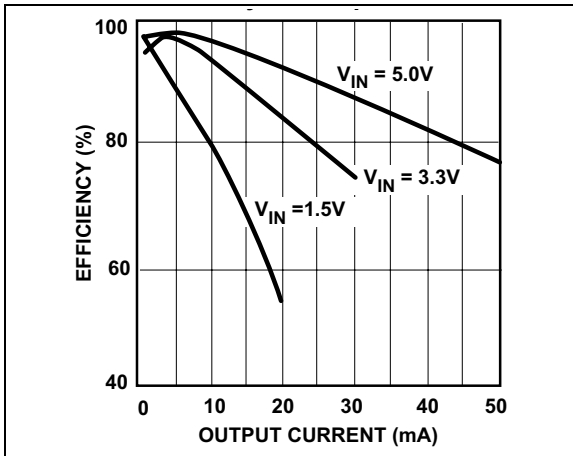


**FIGURE 2-7:** Supply Current vs. Supply Voltage.



**FIGURE 2-10:** Output Voltage vs. Output Current.

**Note:** Circuit of Figure 5-3,  $V_{IN} = +5V$ ,  $C1 = C2 = C3$ ,  $T_A = +25^\circ C$ , unless otherwise noted.



**FIGURE 2-11:** Efficiency vs. Output Current.

# TCM828/TCM829

---

NOTES:



## 3.0 PIN DESCRIPTION

The descriptions of the pins are listed in [Table 3-1](#).

**TABLE 3-1: PIN FUNCTION TABLE**

TCM828/TCM829 SOT-23	Symbol	Function
1	OUT	Inverting charge pump output
2	V <sub>IN</sub>	Positive power supply input
3	C <sub>1</sub> <sup>-</sup>	Commutation capacitor negative terminal
4	GND	Ground
5	C <sub>1</sub> <sup>+</sup>	Commutation capacitor positive terminal

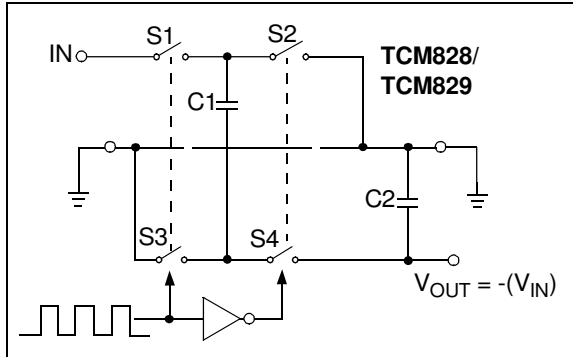
# TCM828/TCM829

---

NOTES:

## 4.0 DETAILED DESCRIPTION

The TCM828/TCM829 charge pump converters invert the voltage applied to the  $V_{IN}$  pin. Conversion consists of a two phase operation (Figure 4-1). During the first phase operation (Figure 4-1). During the first phase, switches S2 and S4 are open, while S1 and S3 are closed. During this time, C1 charges to the voltage on  $V_{IN}$  and load current is supplied from C2. During the second phase, S2 and S4 are closed, and S1 and S3 are open. This action connects C1 across C2, restoring charge to C2.



**FIGURE 4-1:** *Ideal Switched Capacitor Charge Pump.*

# TCM828/TCM829

---

NOTES:

## 5.0 APPLICATIONS INFORMATION

### 5.0.1 OUTPUT VOLTAGE CONSIDERATIONS

The TCM828/TCM829 devices perform voltage conversion, but do not provide regulation. The output voltage will droop in a linear manner with respect to load current. The value of this equivalent output resistance is approximately 25Ω nominal at +25°C and VIN = +5V. VOUT is approximately –5V at light loads, and droops according to the equation below:

$$V_{DROOP} = I_{OUT} \times R_{OUT}$$

$$V_{OUT} = -(V_{IN} - V_{DROOP})$$

### 5.0.2 CHARGE PUMP EFFICIENCY

The overall power efficiency of the charge pump is affected by four factors:

1. Losses from power consumed by the internal oscillator, switch drive, etc. (which vary with input voltage, temperature and oscillator frequency).
2. I<sup>2</sup>R losses due to the on-resistance of the MOSFET switches on-board the charge pump.
3. Charge pump capacitor losses due to effective series resistance (ESR).
4. Losses that occur during charge transfer (from the commutation capacitor to the output capacitor) when a voltage difference between the two capacitors exists.

Most of the conversion losses are due to factors 2, 3 and 4 above. These losses are shown in Equation 5-1.

#### EQUATION 5-1:

$$P_{LOSS(2,3,4)} = I_{OUT}^2 \times R_{OUT}$$

$$\cong I_{OUT}^2 \times \left[ \frac{1}{(f_{OSC})C1} + 8R_{SWITCH} + 4ESR_{C1} + ESR_{C2} \right]$$

The 1/(f<sub>OSC</sub>)(C1) term in Equation 5-1 is the effective output resistance of an ideal switched capacitor circuit (Figures 5-1 and 5-2).

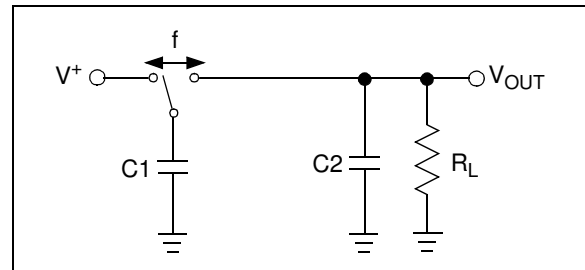
The losses in the circuit due to factor 4 above are also shown in Equation 5-2. The output voltage ripple is shown in Equation 5-3.

#### EQUATION 5-2:

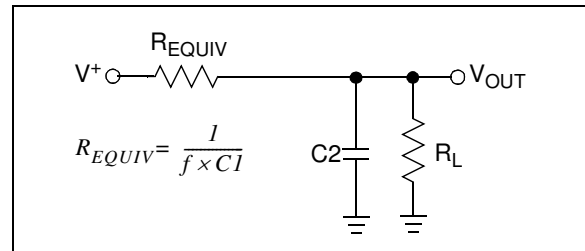
$$P_{LOSS(4)} = [(0.5)(C1)(V_{IN}^2 + V_{OUT}^2) + (0.5)(C2)(V_{RIPPLE}^2 - 2V_{OUT}V_{RIPPLE})] \times f_{OSC}$$

#### EQUATION 5-3:

$$V_{RIPPLE} = \frac{I_{OUT}}{(f_{OSC})(C2)} + 2(I_{OUT})(ESR_{C2})$$



**FIGURE 5-1:** Ideal Switched Capacitor Model.



**FIGURE 5-2:** Equivalent Output Resistance.

# TCM828/TCM829

## 5.0.3 CAPACITOR SELECTION

In order to maintain the lowest output resistance and output ripple voltage, it is recommended that low ESR capacitors be used. Additionally, larger values of C1 will lower the output resistance and larger values of C2 will reduce output ripple. (See Equation 5-1).

Table 5-1 shows various values of C1 and the corresponding output resistance values @ +25°C. It assumes a 0.1Ω ESR<sub>C1</sub> and 2Ω R<sub>SW</sub>. Table 5-2 shows the output voltage ripple for various values of C2. The V<sub>RIPPLE</sub> values assume 10 mA output load current and 0.1Ω ESR<sub>C2</sub>.

**TABLE 5-1: OUTPUT RESISTANCE VS. C1 (ESR = 0.1Ω)**

C1 (μF)	TCM828 R <sub>OUT</sub> (Ω)	TCM829 R <sub>OUT</sub> (Ω)
0.1	850	302
1	100	45
3.3	42	25
10	25	19
47	18	17
100	17	17

**TABLE 5-2: OUTPUT VOLTAGE RIPPLE VS. C2 (ESR = 0.1Ω) I<sub>OUT</sub> 10MA**

C2 (μF)	TCM828 V <sub>RIPPLE</sub> (mV)	TCM829 R <sub>OUT</sub> (Ω)
1	835	286
3.3	254	88
10	85	31
47	20	8
100	10	5

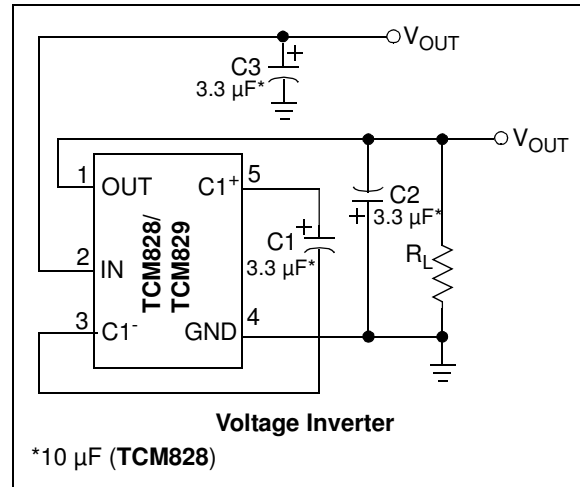
## 5.0.4 INPUT SUPPLY BYPASSING

The V<sub>IN</sub> input should be capacitively bypassed to reduce AC impedance and minimize noise effects due to the switching internal to the device. The recommended capacitor depends on the configuration of the TCM828/TCM829 devices.

If the device is loaded from OUT to GND, it is recommended that a large value capacitor (at least equal to C1) be connected from the input to GND. If the device is loaded from IN to OUT, a small (0.1 μF) capacitor is sufficient.

## 5.0.5 VOLTAGE INVERTER

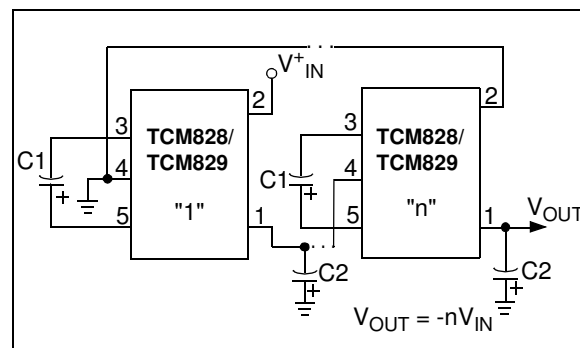
The most common application for charge pump devices is the inverter (Figure 5-3). This application uses two external capacitors – C1 and C2 (plus a power supply bypass capacitor, if necessary). The output is equal to V<sub>IN</sub> plus any voltage drops, due to loading. Refer to Table 5-1 and Table 5-1 for capacitor selection.



**FIGURE 5-3: Test Circuit.**

## 5.0.6 CASCADING DEVICES

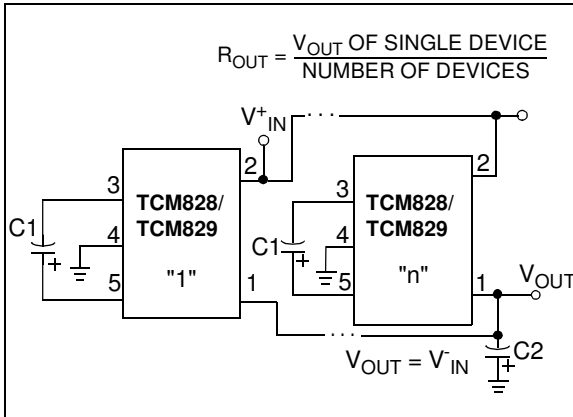
Two or more TCM828/829 devices can be cascaded to increase output voltage (Table 5-4). If the output is lightly loaded, it will be close to (-2 x V<sub>IN</sub>) but will drop at least by R<sub>OUT</sub> of the first device multiplied by the I<sub>Q</sub> of the second. It can be seen that the output resistance rises rapidly for multiple cascaded devices. For large negative voltage requirements see the TC682 or TCM680 data sheets.



**FIGURE 5-4: Cascading TCM828 or TCM829 Devices to Increase Output Voltage.**

## 5.0.7 PARALLELING DEVICES

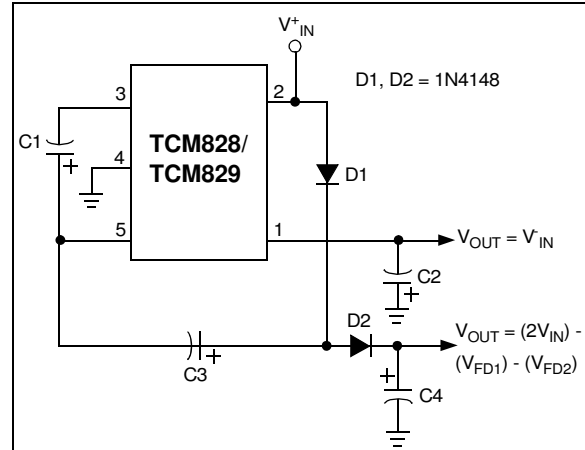
To reduce the value of  $R_{OUT}$ , multiple TCM828/TCM829 devices can be connected in parallel (Figure 5-5). The output resistance will be reduced by a factor of N, where N is the number of TCM828/TCM829 device. Each device will require its own pump capacitor (C1), but all devices may share one reservoir capacitor (C2). However, to preserve ripple performance, the value of C2 should be scaled according to the number of paralleled TCM828/TCM829 devices.



**FIGURE 5-5:** Paralleling TCM828 or TCM829 Devices to Reduce Output Resistance.

## 5.0.8 VOLTAGE DOUBLER/INVERTER

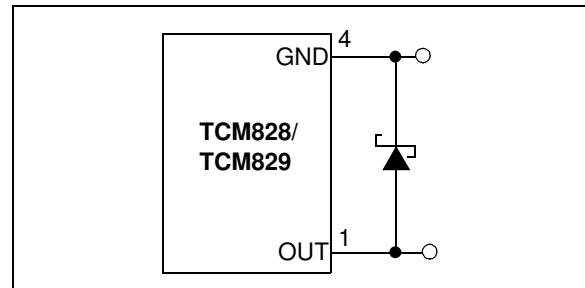
Another common application of the TCM828/TCM829 devices is shown in Figure 5-6. This circuit performs two functions in combination. C1 and C2 form the standard inverter circuit described above. C3 and C4, plus the two diodes, form the voltage doubler circuit. C1 and C3 are the pump capacitors, while C2 and C4 are the reservoir capacitors. Because both sub-circuits rely on the same switches, if either output is loaded, both will drop toward GND. Make sure that the total current drawn from both the outputs does not total more than 40 mA.



**FIGURE 5-6:** Combined Doubler and Inverter.

## 5.0.9 DIODE PROTECTION FOR HEAVY LOADS

When heavy loads require the OUT pin to sink large currents, being delivered by a positive source, diode protection may be needed. The OUT pin should not be allowed to be pulled above ground. This is accomplished by connecting a Schottky diode (1N5817) as shown in Figure 5-7.



**FIGURE 5-7:** High  $V^-$  Load Current.

## 5.0.10 LAYOUT CONSIDERATIONS

As with any switching power supply circuit, good layout practice is recommended. Mount components as close together as possible, to minimize stray inductance and capacitance. Also use a large ground plane to minimize noise leakage into other circuitry.

# TCM828/TCM829

---

NOTES:

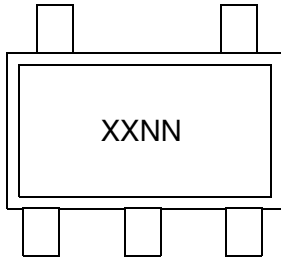


## 6.0 PACKAGING INFORMATION

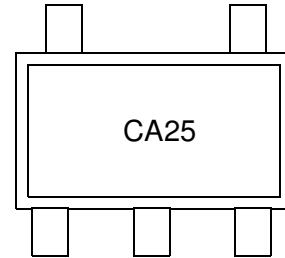
### 6.1 Package Marking Information

5-Lead SOT-23

Example:



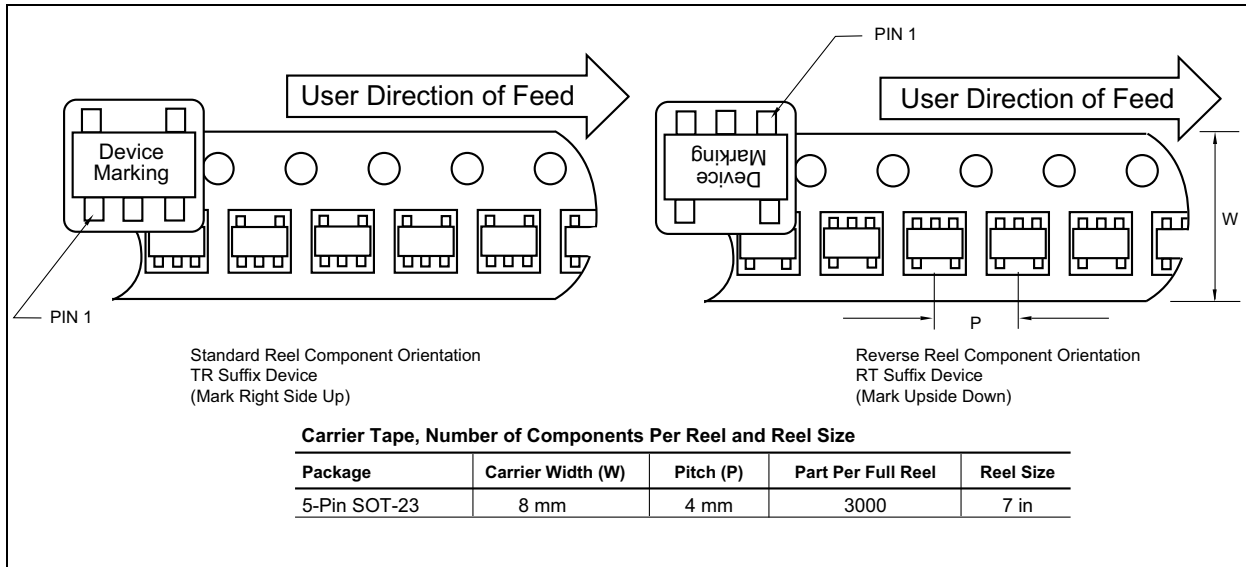
Device	Code
TCM828ECT728	CANN
TCM828VT713	CWNN
TCM829ECT713-GVAO	CBNN



<b>Legend:</b>	XX...X	Customer-specific information
	Y	Year code (last digit of calendar year)
	YY	Year code (last 2 digits of calendar year)
	WW	Week code (week of January 1 is week '01')
	NNN	Alphanumeric traceability code
	(e3)	Pb-free JEDEC designator for Matte Tin (Sn)
	*	This package is Pb-free. The Pb-free JEDEC designator (e3) can be found on the outer packaging for this package.

**Note:** In the event the full Microchip part number cannot be marked on one line, it will be carried over to the next line, thus limiting the number of available characters for customer-specific information.

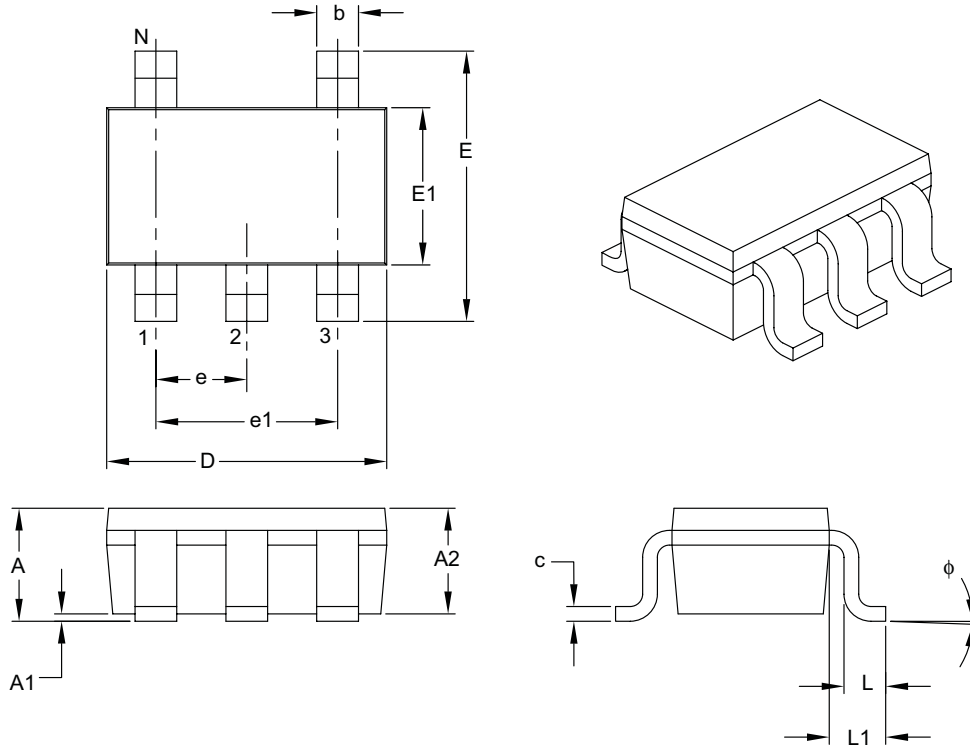
# TCM828/TCM829



**FIGURE 6-1:** Component Taping Orientation for 5-Pin SOT-23 (EIAJ SC-74A) Devices.

## Lead Plastic Small Outline Transistor (CT) [SOT-23]

**Note** For the most current package drawings please see the Microchip Packaging Specification located at <http://www.microchip.com/packaging>



Dimension Limits	Units	MILLIMETERS		
		MIN	NOM	MAX
Number of Pins	N			
Lead Pitch	e		BSC	
Outside Lead Pitch	e1		BSC	
Overall Height	A		-	
Molded Package Thickness	A2		-	
Standoff	A1		-	
Overall Width	E		-	
Molded Package Width	E1		-	
Overall Length	D		-	
Foot Length	L		-	
Footprint	L1		-	
Foot Angle	φ	°	-	°
Lead Thickness	c		-	
Lead Width	b		-	

### Notes

Dimensions D and E do not include mold flash or protrusions. Mold flash or protrusions shall not exceed 0.15 mm per side.

Dimensioning and tolerancing per ASME Y14.5M.

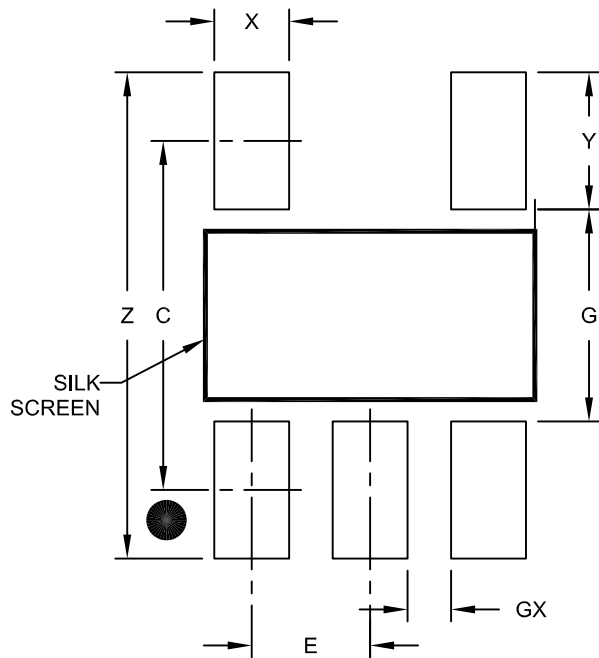
BSC: Basic Dimension. Theoretically exact value shown without tolerances.

Microchip Technology Drawing C0000000B

# TCM828/TCM829

## 5-Lead Plastic Small Outline Transistor (CT) [SOT-23]

**Note:** For the most current package drawings, please see the Microchip Packaging Specification located at <http://www.microchip.com/packaging>



RECOMMENDED LAND PATTERN

Dimension Limits	Units	MILLIMETERS		
		MIN	NOM	MAX
Contact Pitch	E	0.95 BSC		
Contact Pad Spacing	C		2.80	
Contact Pad Width (X5)	X			0.60
Contact Pad Length (X5)	Y			1.10
Distance Between Pads	G	1.70		
Distance Between Pads	GX	0.35		
Overall Width	Z			3.90

**Notes:**

1. Dimensioning and tolerancing per ASME Y14.5M

BSC: Basic Dimension. Theoretically exact value shown without tolerances.

Microchip Technology Drawing No. C04-2091A

## APPENDIX A: REVISION HISTORY

### Revision B (August 2010)

The following is the list of modifications:

1. Added new operating temperature for TCM828 (TCM828VT).
2. Reformatted the original document.
3. Updated package drawings.

### Revision A (March 2001)

- Original Release of this Document.

# TCM828/TCM829

---

NOTES:

## PRODUCT IDENTIFICATION SYSTEM

To order or obtain information, e.g., on pricing or delivery, refer to the factory or the listed sales office.

<u>PART NO.</u>	<u>X</u>	<u>/XX</u>
Device	Temperature Range	Package
Device:	TCM828: CMOS Voltage Converter. TCM829: CMOS Voltage Converter.	
Temperature Range:	E = -40 °C to +85 °C V = -40 °C to +125 °C	
Package:	CT = 5-Lead Plastic Small Outline Transistor, SOT-23.	

**Examples:**

- a) TCM828ECT728: Extended Temp., 5-LD SOT-23 Package.
- b) TCM828VT713: Various Temperature 5-LD SOT-23 Package.
- c) TCM829ECT713-GVAO: Extended Temp., 5-LD SOT-23 Package.

# TCM828/TCM829

---

NOTES:



---

**Note the following details of the code protection feature on Microchip devices:**

- Microchip products meet the specification contained in their particular Microchip Data Sheet.
- Microchip believes that its family of products is one of the most secure families of its kind on the market today, when used in the intended manner and under normal conditions.
- There are dishonest and possibly illegal methods used to breach the code protection feature. All of these methods, to our knowledge, require using the Microchip products in a manner outside the operating specifications contained in Microchip's Data Sheets. Most likely, the person doing so is engaged in theft of intellectual property.
- Microchip is willing to work with the customer who is concerned about the integrity of their code.
- Neither Microchip nor any other semiconductor manufacturer can guarantee the security of their code. Code protection does not mean that we are guaranteeing the product as “unbreakable.”

Code protection is constantly evolving. We at Microchip are committed to continuously improving the code protection features of our products. Attempts to break Microchip's code protection feature may be a violation of the Digital Millennium Copyright Act. If such acts allow unauthorized access to your software or other copyrighted work, you may have a right to sue for relief under that Act.

---

Information contained in this publication regarding device applications and the like is provided only for your convenience and may be superseded by updates. It is your responsibility to ensure that your application meets with your specifications. MICROCHIP MAKES NO REPRESENTATIONS OR WARRANTIES OF ANY KIND WHETHER EXPRESS OR IMPLIED, WRITTEN OR ORAL, STATUTORY OR OTHERWISE, RELATED TO THE INFORMATION, INCLUDING BUT NOT LIMITED TO ITS CONDITION, QUALITY, PERFORMANCE, MERCHANTABILITY OR FITNESS FOR PURPOSE. Microchip disclaims all liability arising from this information and its use. Use of Microchip devices in life support and/or safety applications is entirely at the buyer's risk, and the buyer agrees to defend, indemnify and hold harmless Microchip from any and all damages, claims, suits, or expenses resulting from such use. No licenses are conveyed, implicitly or otherwise, under any Microchip intellectual property rights.

**Trademarks**

The Microchip name and logo, the Microchip logo, dsPIC, KEELOQ, KEELOQ logo, MPLAB, PIC, PICmicro, PICSTART, PIC<sup>32</sup> logo, rPIC and UNI/O are registered trademarks of Microchip Technology Incorporated in the U.S.A. and other countries.


FilterLab, Hampshire, HI-TECH C, Linear Active Thermistor, MXDEV, MXLAB, SEEVAL and The Embedded Control Solutions Company are registered trademarks of Microchip Technology Incorporated in the U.S.A.

Analog-for-the-Digital Age, Application Maestro, CodeGuard, dsPICDEM, dsPICDEM.net, dsPICworks, dsSPEAK, ECAN, ECONOMONITOR, FanSense, HI-TIDE, In-Circuit Serial Programming, ICSP, Mindi, MiWi, MPASM, MPLAB Certified logo, MPLIB, MPLINK, mTouch, Octopus, Omniscient Code Generation, PICC, PICC-18, PICDEM, PICDEM.net, PICkit, PICTail, REAL ICE, rLAB, Select Mode, Total Endurance, TSHARC, UniWinDriver, WiperLock and ZENA are trademarks of Microchip Technology Incorporated in the U.S.A. and other countries.

SQTP is a service mark of Microchip Technology Incorporated in the U.S.A.

All other trademarks mentioned herein are property of their respective companies.

© 2010, Microchip Technology Incorporated, Printed in the U.S.A., All Rights Reserved.

 Printed on recycled paper.

ISBN: 978-1-60932-445-2

*Microchip received ISO/TS-16949:2002 certification for its worldwide headquarters, design and wafer fabrication facilities in Chandler and Tempe, Arizona; Gresham, Oregon and design centers in California and India. The Company's quality system processes and procedures are for its PIC® MCUs and dsPIC® DSCs, KEELOQ® code hopping devices, Serial EEPROMs, microperipherals, nonvolatile memory and analog products. In addition, Microchip's quality system for the design and manufacture of development systems is ISO 9001:2000 certified.*

---

**QUALITY MANAGEMENT SYSTEM  
CERTIFIED BY DNV  
== ISO/TS 16949:2002 ==**



## WORLDWIDE SALES AND SERVICE

### AMERICAS

#### Corporate Office

2355 West Chandler Blvd.  
Chandler, AZ 85224-6199  
Tel: 480-792-7200  
Fax: 480-792-7277  
Technical Support:  
<http://support.microchip.com>  
Web Address:  
[www.microchip.com](http://www.microchip.com)

#### Atlanta

Duluth, GA  
Tel: 678-957-9614  
Fax: 678-957-1455

#### Boston

Westborough, MA  
Tel: 774-760-0087  
Fax: 774-760-0088

#### Chicago

Itasca, IL  
Tel: 630-285-0071  
Fax: 630-285-0075

#### Cleveland

Independence, OH  
Tel: 216-447-0464  
Fax: 216-447-0643

#### Dallas

Addison, TX  
Tel: 972-818-7423  
Fax: 972-818-2924

#### Detroit

Farmington Hills, MI  
Tel: 248-538-2250  
Fax: 248-538-2260

#### Kokomo

Kokomo, IN  
Tel: 765-864-8360  
Fax: 765-864-8387

#### Los Angeles

Mission Viejo, CA  
Tel: 949-462-9523  
Fax: 949-462-9608

#### Santa Clara

Santa Clara, CA  
Tel: 408-961-6444  
Fax: 408-961-6445

#### Toronto

Mississauga, Ontario,  
Canada  
Tel: 905-673-0699  
Fax: 905-673-6509

### ASIA/PACIFIC

#### Asia Pacific Office

Suites 3707-14, 37th Floor  
Tower 6, The Gateway  
Harbour City, Kowloon  
Hong Kong  
Tel: 852-2401-1200  
Fax: 852-2401-3431

#### Australia - Sydney

Tel: 61-2-9868-6733  
Fax: 61-2-9868-6755

#### China - Beijing

Tel: 86-10-8528-2100  
Fax: 86-10-8528-2104

#### China - Chengdu

Tel: 86-28-8665-5511  
Fax: 86-28-8665-7889

#### China - Chongqing

Tel: 86-23-8980-9588  
Fax: 86-23-8980-9500

#### China - Hong Kong SAR

Tel: 852-2401-1200  
Fax: 852-2401-3431

#### China - Nanjing

Tel: 86-25-8473-2460  
Fax: 86-25-8473-2470

#### China - Qingdao

Tel: 86-532-8502-7355  
Fax: 86-532-8502-7205

#### China - Shanghai

Tel: 86-21-5407-5533  
Fax: 86-21-5407-5066

#### China - Shenyang

Tel: 86-24-2334-2829  
Fax: 86-24-2334-2393

#### China - Shenzhen

Tel: 86-755-8203-2660  
Fax: 86-755-8203-1760

#### China - Wuhan

Tel: 86-27-5980-5300  
Fax: 86-27-5980-5118

#### China - Xian

Tel: 86-29-8833-7252  
Fax: 86-29-8833-7256

#### China - Xiamen

Tel: 86-592-2388138  
Fax: 86-592-2388130

#### China - Zhuhai

Tel: 86-756-3210040  
Fax: 86-756-3210049

### ASIA/PACIFIC

#### India - Bangalore

Tel: 91-80-3090-4444  
Fax: 91-80-3090-4123

#### India - New Delhi

Tel: 91-11-4160-8631  
Fax: 91-11-4160-8632

#### India - Pune

Tel: 91-20-2566-1512  
Fax: 91-20-2566-1513

#### Japan - Yokohama

Tel: 81-45-471- 6166  
Fax: 81-45-471-6122

#### Korea - Daegu

Tel: 82-53-744-4301  
Fax: 82-53-744-4302

#### Korea - Seoul

Tel: 82-2-554-7200  
Fax: 82-2-558-5932 or  
82-2-558-5934

#### Malaysia - Kuala Lumpur

Tel: 60-3-6201-9857  
Fax: 60-3-6201-9859

#### Malaysia - Penang

Tel: 60-4-227-8870  
Fax: 60-4-227-4068

#### Philippines - Manila

Tel: 63-2-634-9065  
Fax: 63-2-634-9069

#### Singapore

Tel: 65-6334-8870  
Fax: 65-6334-8850

#### Taiwan - Hsin Chu

Tel: 886-3-6578-300  
Fax: 886-3-6578-370

#### Taiwan - Kaohsiung

Tel: 886-7-213-7830  
Fax: 886-7-330-9305

#### Taiwan - Taipei

Tel: 886-2-2500-6610  
Fax: 886-2-2508-0102

#### Thailand - Bangkok

Tel: 66-2-694-1351  
Fax: 66-2-694-1350

### EUROPE

#### Austria - Wels

Tel: 43-7242-2244-39  
Fax: 43-7242-2244-393

#### Denmark - Copenhagen

Tel: 45-4450-2828  
Fax: 45-4485-2829

#### France - Paris

Tel: 33-1-69-53-63-20  
Fax: 33-1-69-30-90-79

#### Germany - Munich

Tel: 49-89-627-144-0  
Fax: 49-89-627-144-44

#### Italy - Milan

Tel: 39-0331-742611  
Fax: 39-0331-466781

#### Netherlands - Drunen

Tel: 31-416-690399  
Fax: 31-416-690340

#### Spain - Madrid

Tel: 34-91-708-08-90  
Fax: 34-91-708-08-91

#### UK - Wokingham

Tel: 44-118-921-5869  
Fax: 44-118-921-5820

07/15/10