

Customer Information Sheet

DRAWING No.: H3484-42

SHEET 2 OF 2

IF IN DOUBT - ASK

(C)

NOT TO SCALE

THIRD ANGLE PROJECTION

ALL DIMENSIONS IN mm

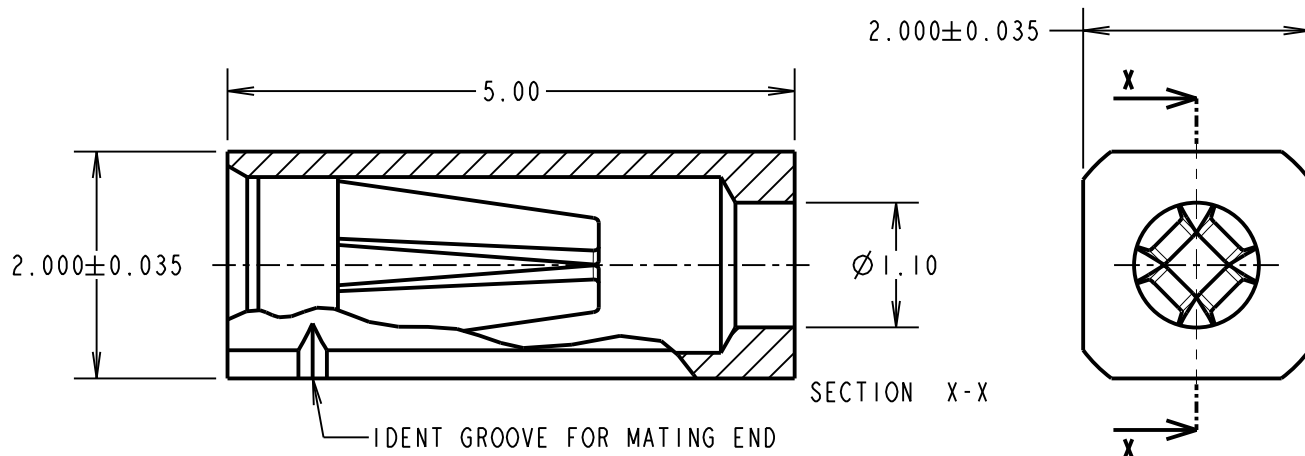

NOTES:
1. FOR TAPE AND REELED VERSION,
SEE DRAWING H3484-42R.

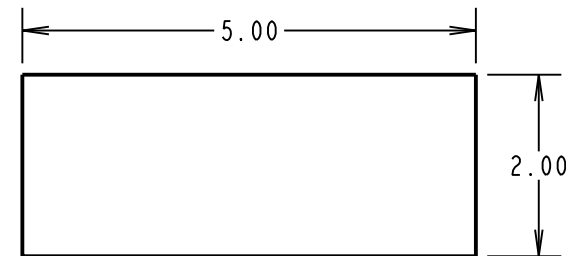

RECOMMENDED
PAD LAYOUT

SPECIFICATIONS:

MATERIALS:

SHELL = BRASS CW614N M TO BS EN 12164

CLIP = BERYLLIUM COPPER C17200 HM

FINISH:

42 = NICKEL ALL OVER,
0.10-0.15µ GOLD CLIP, 3.5-5.0µ 100% TIN SHELL

ELECTRICAL:

CURRENT RATING AT 25°C = 10 AMPS

CURRENT RATING AT 85°C = 7.5 AMP

CONTACT RESISTANCE = 10mΩ MAX

ENVIRONMENTAL:

TEMPERATURE RANGE = -55°C TO +125°C

MECHANICAL:

DURABILITY = 1000 OPERATIONS

INSERTION FORCE (Ø1.00mm GAUGE) = 9.0N MAX, 3.0N MIN.

WITHDRAWAL FORCE (Ø1.00mm GAUGE) = 3.0N MAX, 1.0N MIN

MATING PIN SIZE = Ø1.05-0.90mm

CONTACT DEPTH = 4.1mm MAX.

FOR COMPLETE MECHANICAL AND ELECTRICAL SPECIFICATION
SEE COMPONENT SPECIFICATION C009XX (LATEST ISSUE).



SB	7	13.08.14	12551
NAME	ISS.	DATE	C/NOTE
APPROVED: S.BENNETT			
CHECKED: S.FLOWER			
DRAWN: I.SANDY			
CUSTOMER REF.:			
ASSEMBLY DRG:			

HARWIN

www.harwin.com
technical@harwin.com

THIS DRAWING AND ANY
INFORMATION OR DESCRIPTIVE
MATTER SET OUT HEREON ARE
CONFIDENTIAL AND COPYRIGHT
PROPERTY OF THE HARWIN
GROUP AND MUST NOT BE
DISCLOSED, LOANED, COPIED
OR USED FOR MANUFACTURING,
TENDERING OR FOR ANY
OTHER PURPOSE WITHOUT
THEIR WRITTEN PERMISSION.

TOLERANCES

X. = ±1mm
X.X = ±0.25mm
X.XX = ±0.10mm
X.XXX = ±0.01mm

ANGLES = ±5°
UNLESS STATED

MATERIAL:

SEE ABOVE

FINISH: SEE ABOVE

S/AREA: mm²

TITLE:

Ø1.00mm SURFACE MOUNT
TEST SOCKET ASSEMBLY

DRAWING NUMBER:

H3484-42

SHT
2 OF 2