

# Customer Information Sheet

DRAWING No.: H8501-XX

SHEET 2 OF 2

IF IN DOUBT - ASK

©

NOT TO SCALE

THIRD ANGLE PROJECTION

ALL DIMENSIONS IN mm

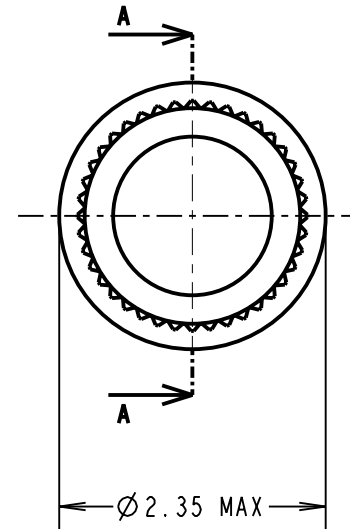
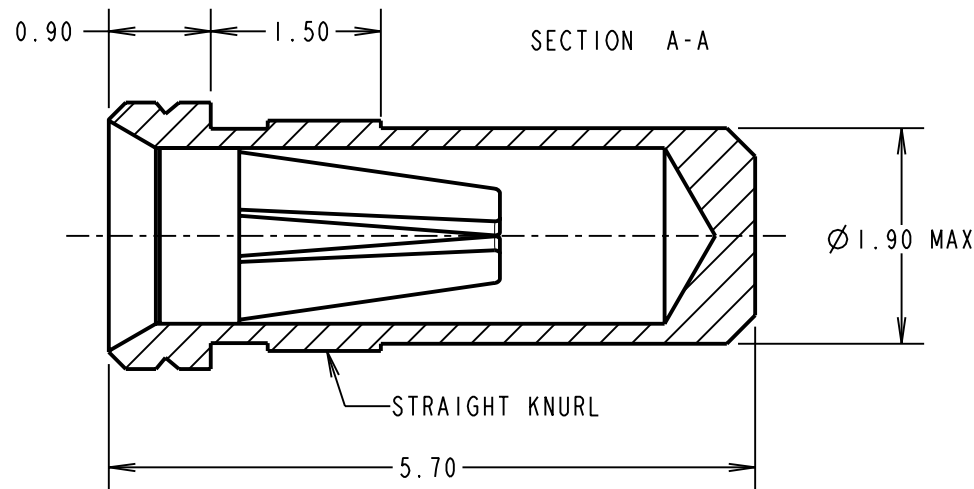

ORDER CODE:

**H8501-XX**

FINISH:

- 01 = 100% TIN SHELL, GOLD CLIP
- 05 = GOLD SHELL, GOLD CLIP
- 46 = 100% TIN SHELL, 100% TIN CLIP

**SPECIFICATION:**

**MATERIAL:**

CONTACT SHELL = BRASS  
CONTACT CLIP = BERYLLIUM COPPER

**FINISH:**

- 01 = 4 $\mu$  100% TIN SHELL, 0.15 $\mu$  GOLD CLIP
- 05 = 0.1 $\mu$  GOLD SHELL, 0.15 $\mu$  GOLD CLIP
- 46 = 4 $\mu$  100% TIN SHELL, 3 $\mu$  100% TIN CLIP

**ELECTRICAL:**

CURRENT RATING AT 25°C = 10A MAX  
CURRENT RATING AT 85°C = 7.5A MAX  
CONTACT RESISTANCE = 25 m $\Omega$  MAX

**MECHANICAL:**

INSERTION FORCE ( $\varnothing$ 0.8mm GAUGE) = 5N MAX, 1.5N MIN  
WITHDRAWAL FORCE ( $\varnothing$ 0.8mm GAUGE) = 3.0N MAX, 1.0N MIN  
**DURABILITY:**

- 01, 05 = 1000 OPERATIONS
- 46 = 100 OPERATIONS

**ENVIRONMENTAL:**

OPERATING TEMPERATURE = -55°C TO +125°C

**PACKING:**

BAG

**NOTES:**

1. FOR ELECTRICAL/MECHANICAL SPECIFICATION, SEE COMPONENT SPECIFICATION C010XX (LATEST ISSUE).
2. MAXIMUM PIN LENGTH = 4.65mm.
3. RECOMMENDED MOUNTING HOLE SIZE =  $\varnothing$ 1.96-1.91mm.
4. RECOMMENDED MATING PIN SIZE =  $\varnothing$ 0.85-0.60mm.
5. MAXIMUM CONTACT DEPTH = 3.30mm.

CP	13	17.12.09	10616
NAME	ISS.	DATE	C/NOTE
APPROVED:		C. PENROSE	
CHECKED:		R. ADDE	
DRAWN:		A. J. FILLINGHAM	
CUSTOMER REF.:			
ASSEMBLY DRG:			

**HARWIN**

HARWIN USA TEL: 603 893 5376 FAX: 603 893 5396 mis@harwin.com	HARWIN Europe (UK) TEL: 023 9231 4545 FAX: 023 9231 4590 mis@harwin.co.uk	HARWIN Asia TEL: +65 6 779 4909 FAX: +65 6 779 3868 mis@harwin.com.sg
--	--	--

THIS DRAWING AND ANY INFORMATION OR DESCRIPTIVE MATTER SET OUT HEREON ARE CONFIDENTIAL AND COPYRIGHT PROPERTY OF THE HARWIN GROUP AND MUST NOT BE DISCLOSED, LOANED, COPIED OR USED FOR MANUFACTURING, TENDERING OR FOR ANY OTHER PURPOSE WITHOUT THEIR WRITTEN PERMISSION.

**TOLERANCES**

- X. =  $\pm$ 1mm
- X.X =  $\pm$ 0.25mm
- X.XX =  $\pm$ 0.10mm
- X.XXX =  $\pm$ 0.01mm

ANGLES =  $\pm$ 5°  
UNLESS STATED

**MATERIAL:**

SEE ABOVE

FINISH: SEE ABOVE

S/AREA: mm<sup>2</sup>

**TITLE:**

$\varnothing$ 0.8mm SOCKET ASSEMBLY

DRAWING NUMBER:

**H8501-XX**

SHT  
2  
OF  
2