

Customer Information Sheet

DRAWING No.: M20-786XXXXP

SHEET 2 OF 2

IF IN DOUBT - ASK

©

NOT TO SCALE

THIRD ANGLE PROJECTION

ALL DIMENSIONS IN mm

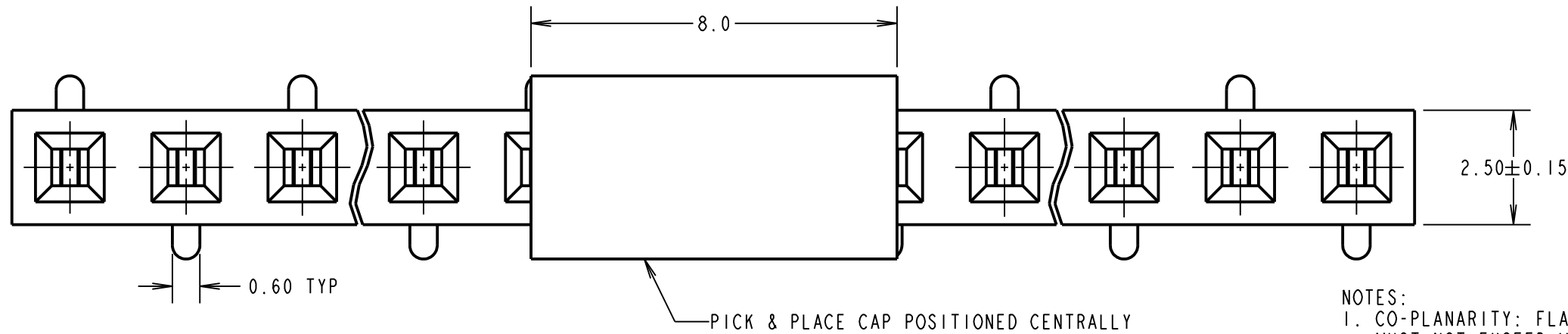

No OF CONTACTS	COPLANARITY TOLERANCE
1x02 TO 1x10	0.12mm MAX
1x11 TO 1x15	0.15mm MAX
1x16 TO 1x20	0.15mm MAX
1x21 TO 1x25	0.20mm MAX
1x26 TO 1x30	0.25mm MAX
1x31 TO 1x35	0.30mm MAX
1x36 TO 1x40	0.35mm MAX

NOTES:
1. CO-PLANARITY: FLATNESS OF SMT TAILS MUST NOT EXCEED VALUES GIVEN IN TABLE.

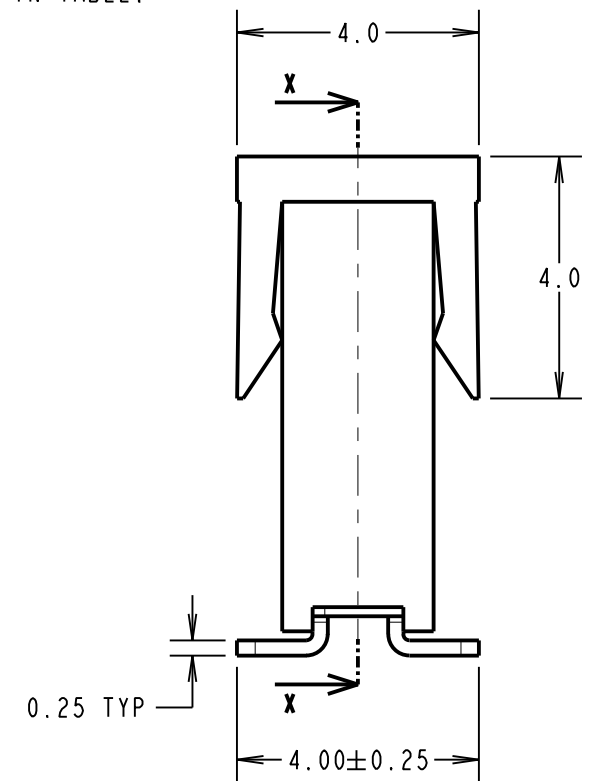
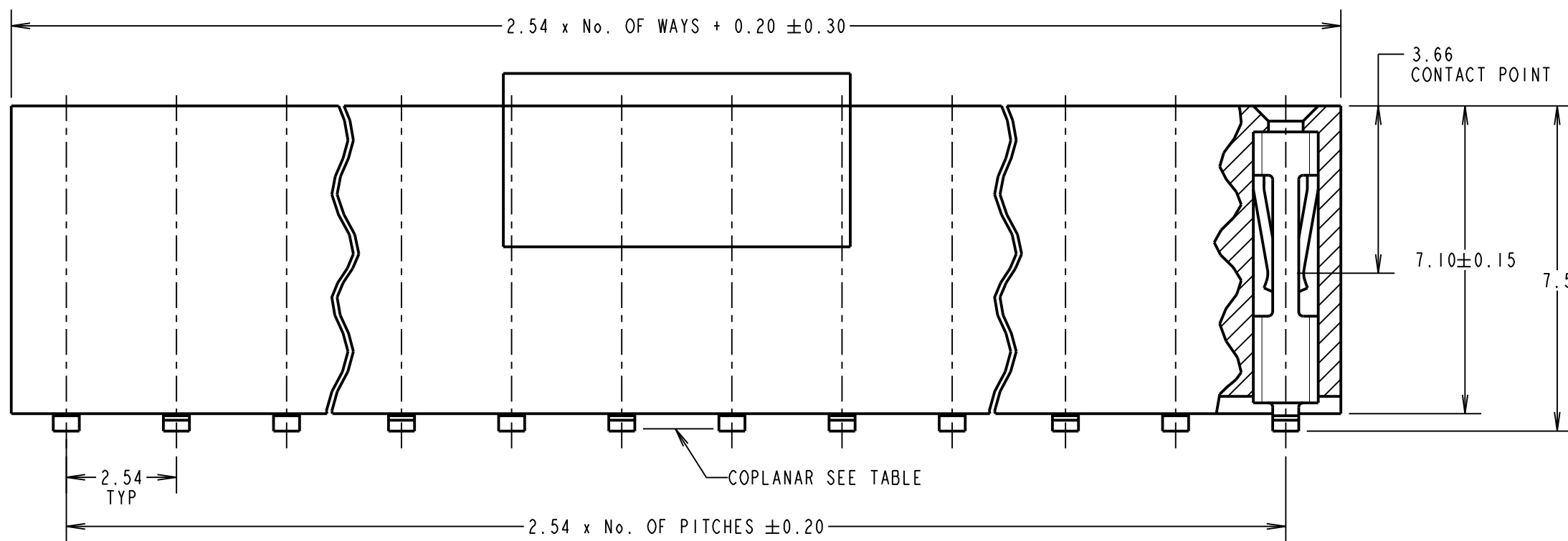

SPECIFICATION:
MATERIAL:
 MOULDING = NYLON 6T UL94V-0, BLACK
 CONTACTS = PHOSPHOR BRONZE
FINISH (COVER NICKEL):
 42 = GOLD ON CONTACT AREA, 100% TIN ON TAILS
 46 = 100% TIN
ELECTRICAL:
 CURRENT RATING = 3A
 VOLTAGE PROOF = 600V AC FOR 1 MINUTE
 CONTACT RESISTANCE = 20 MILLIOHMS MAX
 INSULATION RESISTANCE = 1,000 MEGOHMS MIN
MECHANICAL:
 INSERTION FORCE = 2.0N MAX
 WITHDRAWAL FORCE = 0.3N MIN
ENVIRONMENTAL:
 TEMPERATURE RANGE = -40° TO +105°
PACKING:
 TUBE
 FOR COMPLETE COMPONENT SPECIFICATION SEE COMPONENT SPECIFICATION COOIXX (LATEST ISSUE).

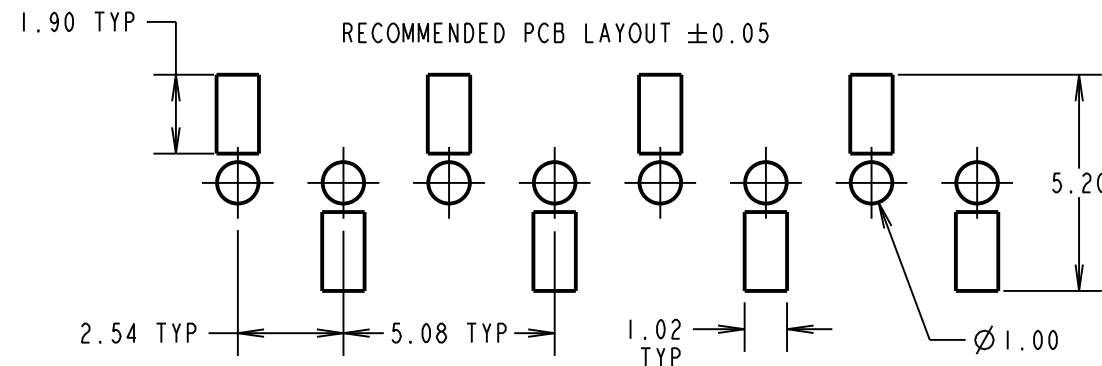

ORDER CODE:
M20-786XXXXP
 No. OF WAYS _____
 02 TO 40
 FINISH _____
 42 - SELECTIVE GOLD + 100% TIN
 46 - 100% TIN

SM	7	25.02.11	11156
NAME	ISS.	DATE	C/NOTE
APPROVED: S. MCCULLAGH			
CHECKED: R. ADDE			
DRAWN: J. BROOKES			
CUSTOMER REF.:			
ASSEMBLY DRG:			

HARWIN			THIS DRAWING AND ANY INFORMATION OR DESCRIPTIVE MATTER SET OUT HEREON ARE CONFIDENTIAL AND COPYRIGHT PROPERTY OF THE HARWIN GROUP AND MUST NOT BE DISCLOSED, LOANED, COPIED OR USED FOR MANUFACTURING, TENDERING OR FOR ANY OTHER PURPOSE WITHOUT THEIR WRITTEN PERMISSION.	TOLERANCES X. = ±1mm X.X = ±0.25mm X.XX = ±0.10mm X.XXX = ±0.01mm ANGLES = ±5° UNLESS STATED	MATERIAL: SEE ABOVE	TITLE: 2.54mm PITCH SIL VERTICAL FEMALE SMT SKT ASSY DUAL ENTRY - PICK/PLACE CAP
HARWIN USA TEL: 603 893 5376 FAX: 603 893 5396 mis@harwin.com	HARWIN Europe (UK) TEL: 023 9231 4545 FAX: 023 9231 4590 mis@harwin.co.uk	HARWIN Asia TEL: +65 6 779 4909 FAX: +65 6 779 3868 mis@harwin.com.sg		FINISH: SEE ABOVE S/AREA: mm ²	DRAWING NUMBER: M20-786XXXXP	SHT 2 OF 2