

Customer Information Sheet

DRAWING No.: M22-273XXX

SHEET 2 OF 2

IF IN DOUBT - ASK



NOT TO SCALE

THIRD ANGLE PROJECTION

ALL DIMENSIONS IN mm

ORDER CODE:
M22-273XXX

No. OF CONTACTS: _____
02 TO 20

FINISH: _____
05 = GOLD FLASH OVER NICKEL
46 = 100% TIN OVER NICKEL

RECOMMENDED PCB LAYOUT
(TOLERANCE = ± 0.05)

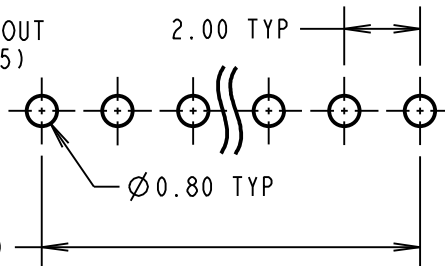

(2.00 x No. OF CONTACTS - 1)

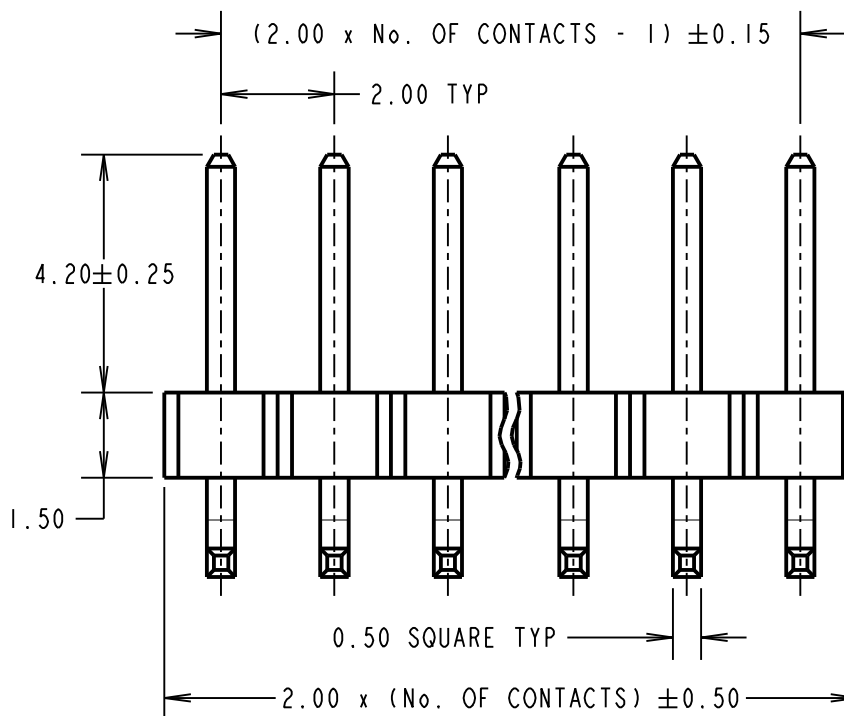
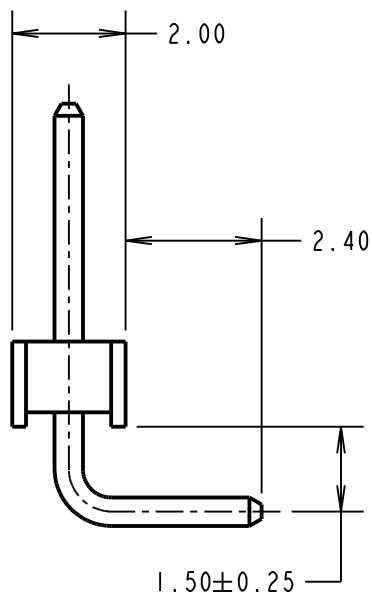

SPECIFICATIONS:

MATERIAL:

MOULDING = NYLON 6T, UL94V-0, BLACK

CONTACTS = PHOSPHOR BRONZE

FINISH:

05 = GOLD FLASH OVER NICKEL

46 = 100% TIN OVER NICKEL

ELECTRICAL:

CURRENT RATING = 2A

VOLTAGE PROOF = 500V AC FOR ONE MINUTE

CONTACT RESISTANCE = 20mΩ MAX

INSULATION RESISTANCE:

INITIAL = 1,000 MΩ MIN

MECHANICAL:

DURABILITY = 300 OPERATIONS MIN

ENVIRONMENTAL:

TEMPERATURE RANGE = -40°C TO +105°C

PACKING:

BAG

FOR COMPLETE SPECIFICATION, SEE
COMPONENT SPECIFICATION C018XX (LATEST ISSUE)

NOTES:

1. ALL TOLERANCES ARE ± 0.20 UNLESS OTHERWISE STATED.

MSP	4	15.06.15	12803
NAME	ISS.	DATE	C/NOTE
APPROVED:		M.PERREN	
CHECKED:		S.BENNETT	
DRAWN:		S.BENNETT	
CUSTOMER REF.:			
ASSEMBLY DRG:			

HARWIN

www.harwin.com
technical@harwin.com

THIS DRAWING AND ANY INFORMATION OR DESCRIPTIVE MATTER SET OUT HEREON ARE CONFIDENTIAL AND COPYRIGHT PROPERTY OF THE HARWIN GROUP AND MUST NOT BE DISCLOSED, LOANED, COPIED OR USED FOR MANUFACTURING, TENDERING OR FOR ANY OTHER PURPOSE WITHOUT THEIR WRITTEN PERMISSION.

TOLERANCES
~~X.X = ± 1 mm~~
~~X.X = ± 0.50 mm~~
~~X.XX = ± 0.10 mm~~
~~X.XXX = ± 0.01 mm~~
ANGLES = $\pm 5^\circ$
UNLESS STATED

MATERIAL:

SEE ABOVE

FINISH:

SEE ABOVE

S/AREA:

mm²

TITLE:

2.00mm PITCH SIL HORIZONTAL
PC TAIL PIN HEADER ASSEMBLY

DRAWING NUMBER:

M22-273XXX

SHT
2
OF 2