

Customer Information Sheet

DRAWING No.: M80-04100XX

SHEET 2 OF 2

IF IN DOUBT - ASK



NOT TO SCALE

THIRD ANGLE PROJECTION

ALL DIMENSIONS IN mm

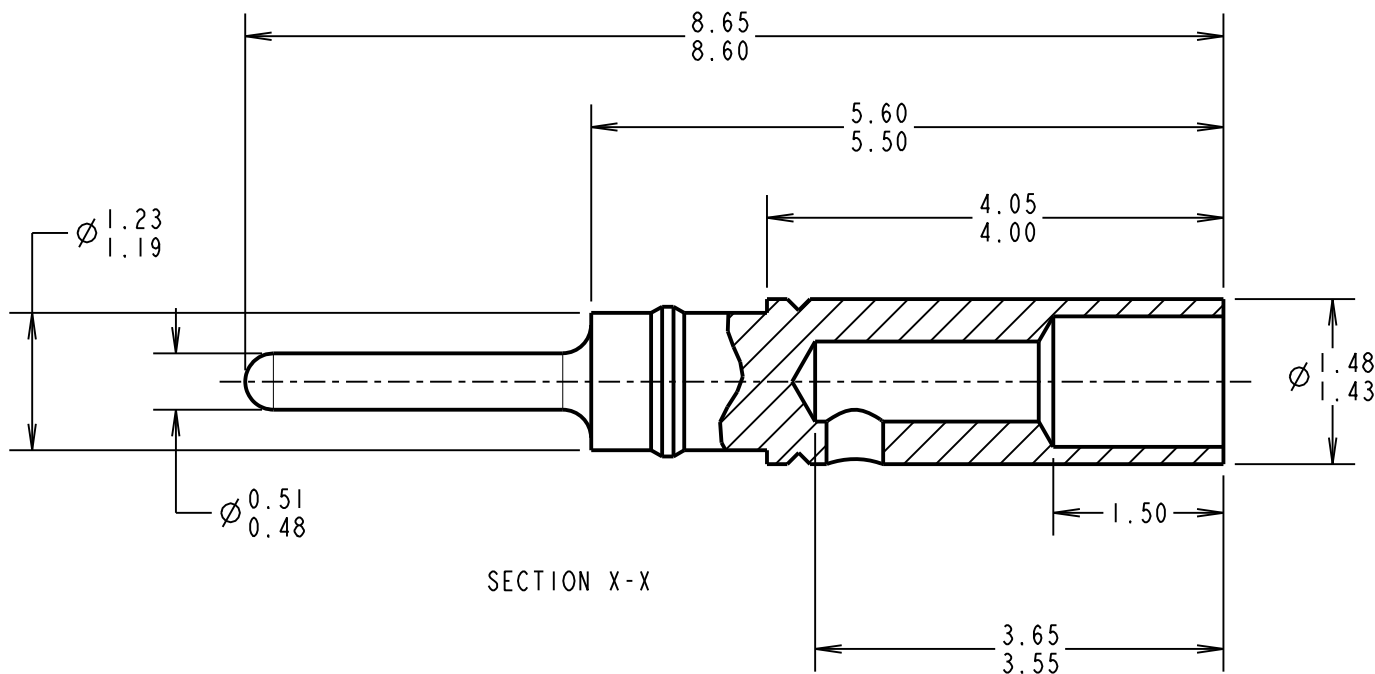

NOTES:

- FOR USE WITH 24-28 AWG BS3G210 TYPE A PTFE INSULATED EQUIPMENT WIRE, MAXIMUM DIAMETER $\varnothing 1.10$ mm.
- TO BE USED AS REPLACEMENT CONTACTS IN SMALL BORE MALE CRIMP DATAMATE ASSEMBLIES M80-812XXXX (LATCHED) AND M80-816XXXX (FRICTION LATCH).
- SEE INSTRUCTION SHEET IS-01 FOR CRIMPING INSTRUCTIONS.

ORDER CODE:
M80-0410005
 FINISH _____
 05 - 0.25-0.30 μ GOLD

WJB	14	13.03.14	12423
NAME	ISS.	DATE	C/NOTE
APPROVED: W. J. BOURNE			
CHECKED: S.BENNETT			
DRAWN: W. J. BOURNE			
CUSTOMER REF.:			
ASSEMBLY DRG:			

HARWIN

www.harwin.com
 technical@harwin.com

THIS DRAWING AND ANY INFORMATION OR DESCRIPTIVE MATTER SET OUT HEREON ARE CONFIDENTIAL AND COPYRIGHT PROPERTY OF THE HARWIN GROUP AND MUST NOT BE DISCLOSED, LOANED, COPIED OR USED FOR MANUFACTURING, TENDERING OR FOR ANY OTHER PURPOSE WITHOUT THEIR WRITTEN PERMISSION.

TOLERANCES
 X. = ± 1 mm
 X.X = ± 0.25 mm
 X.XX = ± 0.10 mm
 X.XXX = ± 0.01 mm
 ANGLES = $\pm 5^\circ$
 UNLESS STATED

MATERIAL:
 BRASS
FINISH: SEE ORDER CODE
S/AREA: mm²

TITLE:
 CRIMP PLUG CONTACT (SMALL BORE)
DRAWING NUMBER:
M80-0410005
 SHT 2 OF 2