

Customer Information Sheet

DRAWING No.: M80-827XXXXP

SHEET 2 OF 2

IF IN DOUBT - ASK

©

NOT TO SCALE

THIRD ANGLE PROJECTION

ALL DIMENSIONS IN mm

ORDER CODE:
M80-827XXXXP

TOTAL No. OF CONTACTS:
04, 06, 08, 10, 12, 14
16, 18, 20, 26, 34, 44

FINISH:
22 - SELECTIVE GOLD + TIN/LEAD
42 - SELECTIVE GOLD + 100% TIN
45 - GOLD

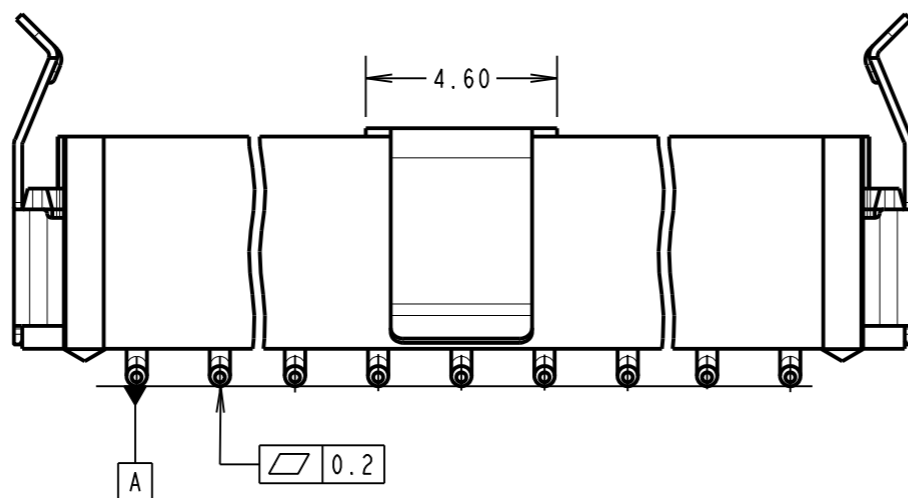
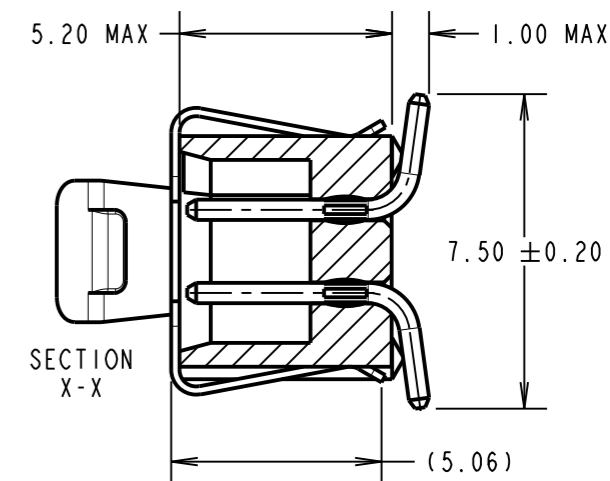
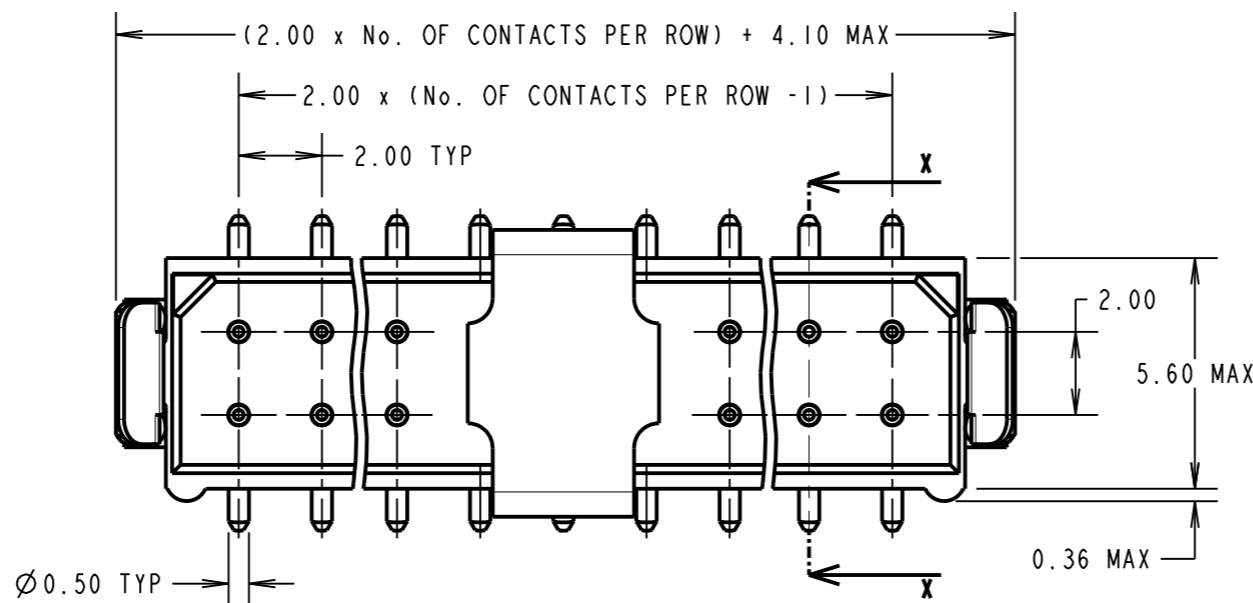

NOTES:
1. 2-OFF STRAIN RELIEF STRAPS
M80-0030006 MAY BE USED WITH
THIS CONNECTOR.

SPECIFICATIONS:

MATERIAL:
MOULDING = G-F PPS UL94V-0, BLACK
CONTACTS = PHOSPHOR BRONZE
LATCHES - BERYLLIUM COPPER
PICK/PLACE CAP = PHOSPHOR BRONZE

FINISH:
CONTACTS:
22 = 0.75µ GOLD ON CONTACT AREA,
3.0µ 90/10 TIN/LEAD ON TAILS
42 = 0.75µ GOLD ON CONTACT AREA,
3.0µ 100% TIN OVER NICKEL ON TAILS
45 = 0.75µ GOLD ALL OVER
LATCH = 1.25µ NICKEL

ELECTRICAL:
CURRENT RATING AT 25°C = 3.0A MAX
CURRENT RATING AT 85°C = 2.2A MAX
WORKING VOLTAGE = 800V AC/DC
VOLTAGE PROOF = 1200V AC/DC
CONTACT RESISTANCE (INITIAL) = 20mΩ MAX
CONTACT RESISTANCE (AFTER CONDITIONING) = 25mΩ MAX
INSULATION RESISTANCE (INITIAL) = 1,000MΩ MIN
INSULATION RESISTANCE (AFTER CONDITIONING) = 100MΩ MIN

MECHANICAL:
DURABILITY = 500 OPERATIONS
ENVIRONMENTAL:
TEMPERATURE RANGE = -55°C TO +125°C
PACKING:
TUBE

FOR COMPLETE SPECIFICATION, SEE COMPONENT SPECIFICATION C005XX (LATEST ISSUE)

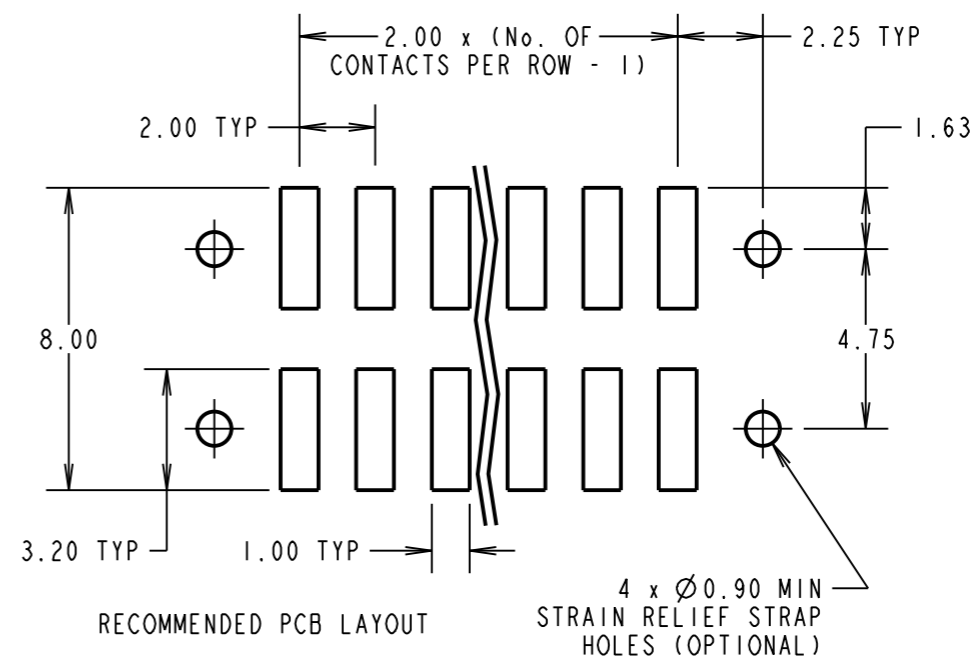

SB	8	19.03.14	12414
NAME	ISS.	DATE	C/NOTE
APPROVED: S.BENNETT			
CHECKED: M.PLESTED			
DRAWN: J. EVANS			
CUSTOMER REF.:			
ASSEMBLY DRG:			

HARWIN
www.harwin.com
technical@harwin.com

THIS DRAWING AND ANY INFORMATION OR DESCRIPTIVE MATTER SET OUT HEREON ARE CONFIDENTIAL AND COPYRIGHT PROPERTY OF THE HARWIN GROUP AND MUST NOT BE DISCLOSED, LOANED, COPIED OR USED FOR MANUFACTURING, TENDERING OR FOR ANY OTHER PURPOSE WITHOUT THEIR WRITTEN PERMISSION.

TOLERANCES
X. = ±1mm
X.X = ±0.25mm
X.XX = ±0.10mm
X.XXX = ±0.01mm
ANGLES = ±5°
UNLESS STATED

MATERIAL:
SEE ABOVE
FINISH: SEE ABOVE
S/AREA: mm²

TITLE: DATAMATE L-TEK MALE DIL VERTICAL SMT ASSY. FRICTION LATCH, P/PLACE
DRAWING NUMBER: M80-827XXXXP
SHT 2 OF 2