

Customer Information Sheet

DRAWING No.: M80-828XXXXP

SHEET 2 OF 2

IF IN DOUBT - ASK

©

NOT TO SCALE

THIRD ANGLE PROJECTION

ALL DIMENSIONS IN mm

ORDER CODE:

M80-828XXXXP

TOTAL No. OF WAYS

04, 06, 08, 10, 12
14, 16, 18, 20, 26
34, 44

FINISH

22 - SELECTIVE GOLD
+ TIN/LEAD
42 - SELECTIVE GOLD
+ 100% TIN
45 - GOLD

SPECIFICATIONS:

MATERIAL:

MOULDING = G-F PPS UL94V-0, BLACK
CONTACTS = PHOSPHOR BRONZE
LATCHES = BERYLLIUM COPPER
PICK/PLACE CAP = PHOSPHOR BRONZE

FINISH:

CONTACTS:

22 = 0.75µ GOLD ON CONTACT AREA,
3.0µ 90/10 TIN/LEAD ON TAILS
42 = 0.75µ GOLD ON CONTACT AREA,
3.0µ 100% TIN OVER NICKEL ON TAILS
45 = 0.75µ GOLD ALL OVER
LATCH = 1.25µ NICKEL

ELECTRICAL:

CURRENT RATING AT 25°C = 3.0A MAX
CURRENT RATING AT 85°C = 2.2A MAX
WORKING VOLTAGE = 800V AC/DC
VOLTAGE PROOF = 1200V AC/DC
CONTACT RESISTANCE (INITIAL) = 20 mΩ MAX
CONTACT RESISTANCE (AFTER CONDITIONING) = 25 mΩ MAX
INSULATION RESISTANCE (INITIAL) = 1,000 MΩ MIN
INSULATION RESISTANCE (AFTER CONDITIONING) = 100 MΩ MIN

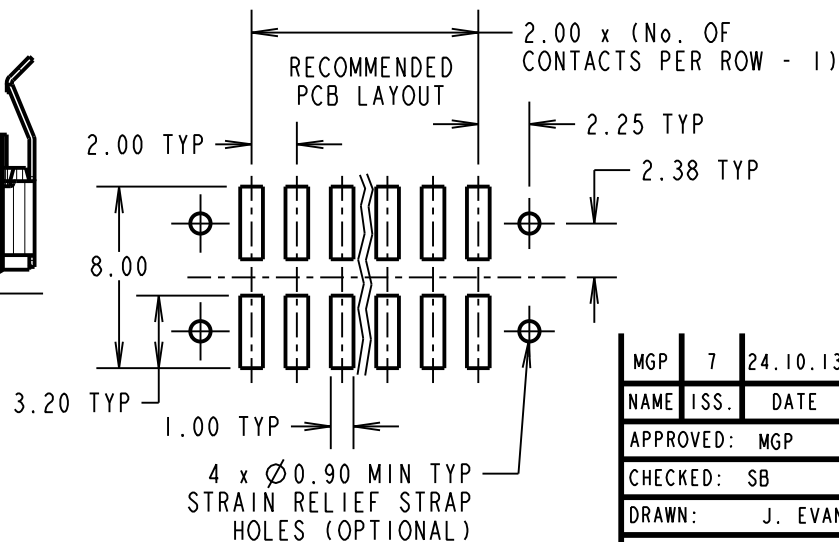
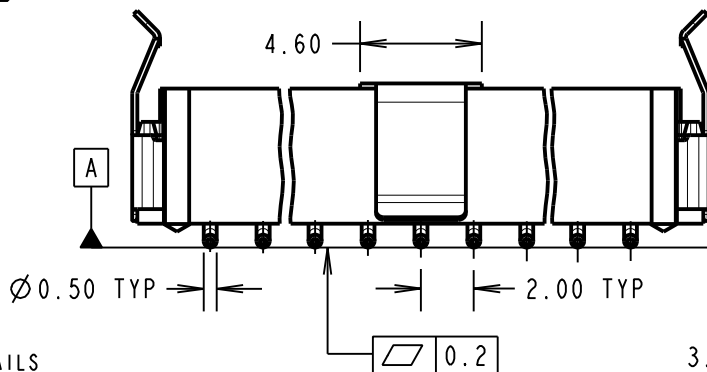
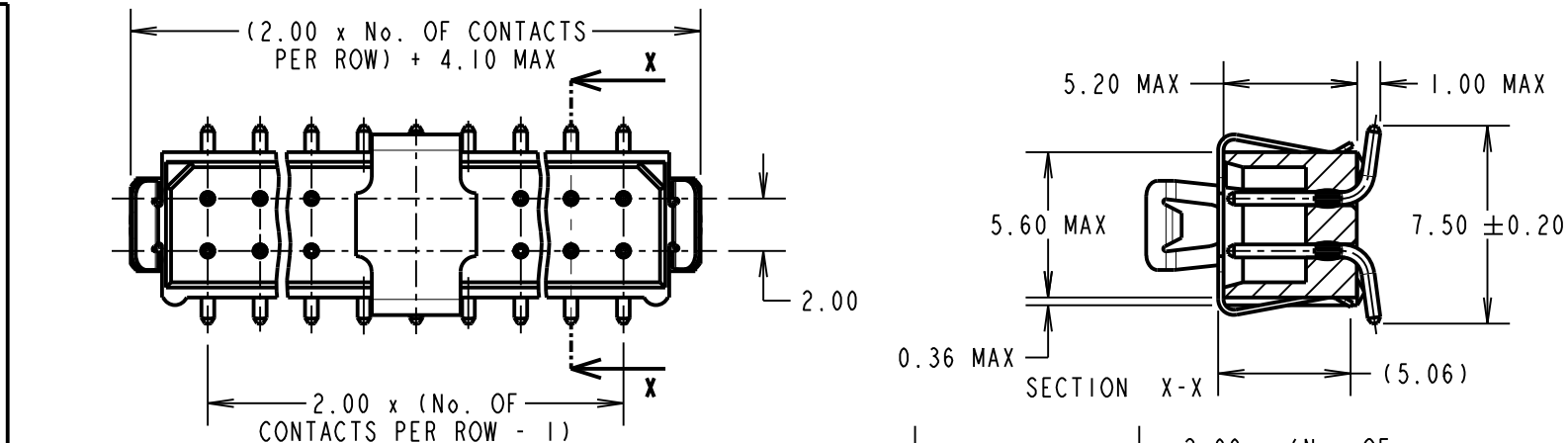

MECHANICAL:
DURABILITY = 500 OPERATIONS
ENVIRONMENTAL:
TEMPERATURE RANGE = -55°C TO +125°C
PACKING:
TUBE
FOR COMPLETE SPECIFICATION, SEE COMPONENT SPECIFICATION C005XX (LATEST ISSUE)

NOTES:

1. 2-OFF STRAIN RELIEF STRAPS
M80-0030006 MAY BE USED
WITH THIS CONNECTOR.

MGP	7	24.10.13	12232
NAME	ISS.	DATE	C/NOTE
APPROVED: MGP			
CHECKED: SB			
DRAWN:		J. EVANS	
CUSTOMER REF.:			
ASSEMBLY DRG:			

HARWIN

www.harwin.com
technical@harwin.com

THIS DRAWING AND ANY INFORMATION OR DESCRIPTIVE MATTER SET OUT HEREON ARE CONFIDENTIAL AND COPYRIGHT PROPERTY OF THE HARWIN GROUP AND MUST NOT BE DISCLOSED, LOANED, COPIED OR USED FOR MANUFACTURING, TENDERING OR FOR ANY OTHER PURPOSE WITHOUT THEIR WRITTEN PERMISSION.

TOLERANCES
X. = ±1mm
X.X = ±0.25mm
X.XX = ±0.10mm
X.XXX = ±0.01mm
ANGLES = ±5°
UNLESS STATED

MATERIAL:
SEE ABOVE
FINISH: SEE ABOVE
S/AREA: mm²

TITLE: DATAMATE L-TEK
MALE DIL VERTICAL SMT
ASSEMBLY - LATCHED, P/PLACE
DRAWING NUMBER:
M80-828XXXXP

SHT
2
OF 2