

# Customer Information Sheet

DRAWING No.: M90-702XX45

SHEET 2 OF 2

IF IN DOUBT - ASK

©

NOT TO SCALE

THIRD ANGLE PROJECTION

ALL DIMENSIONS IN mm

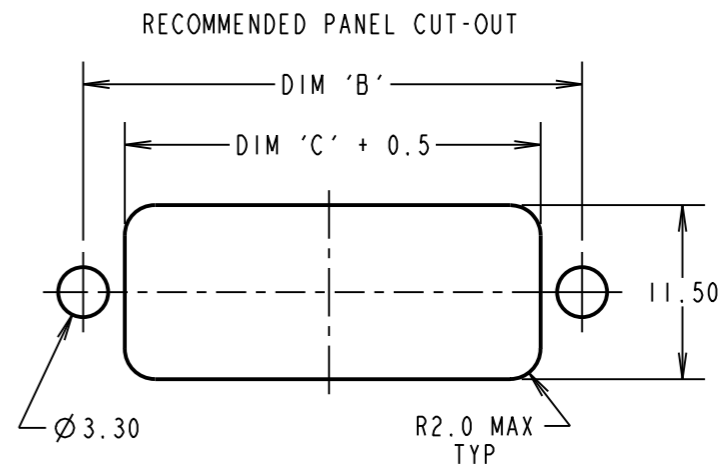
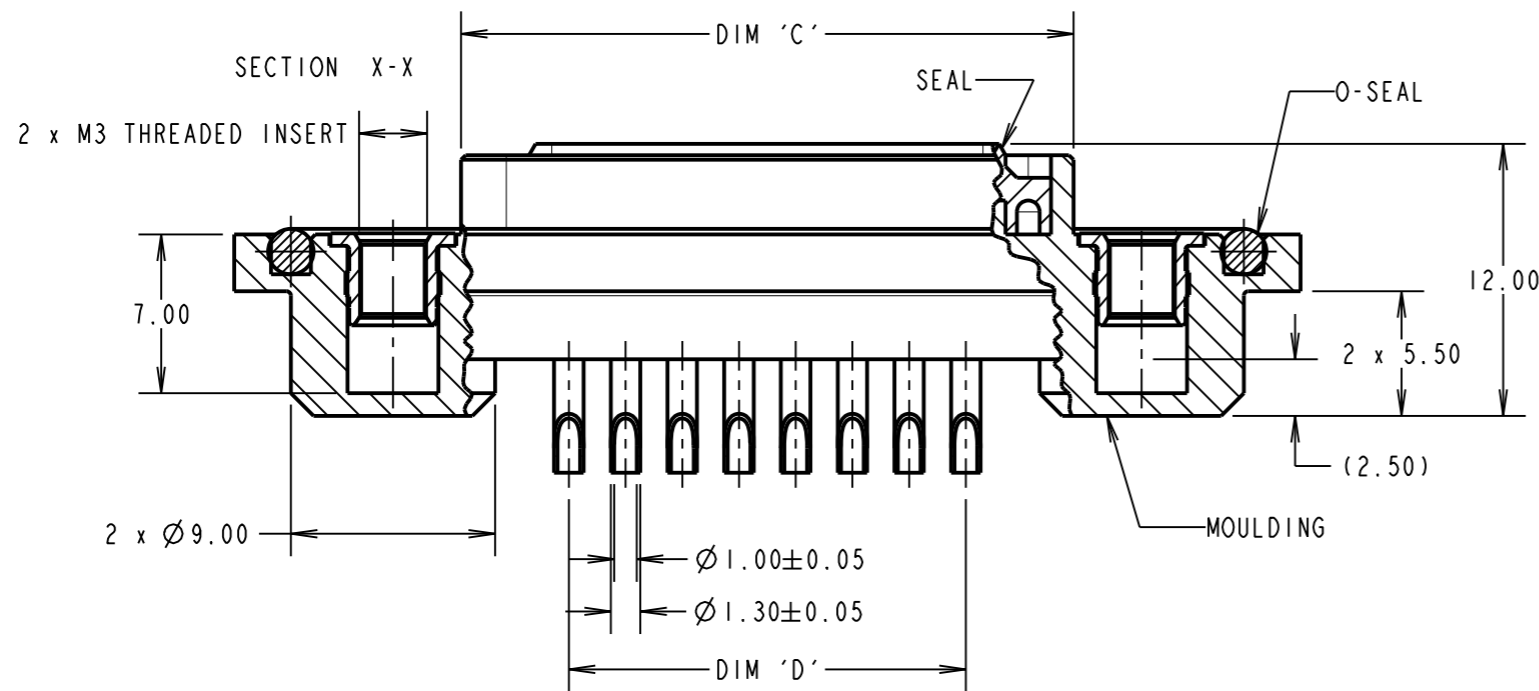
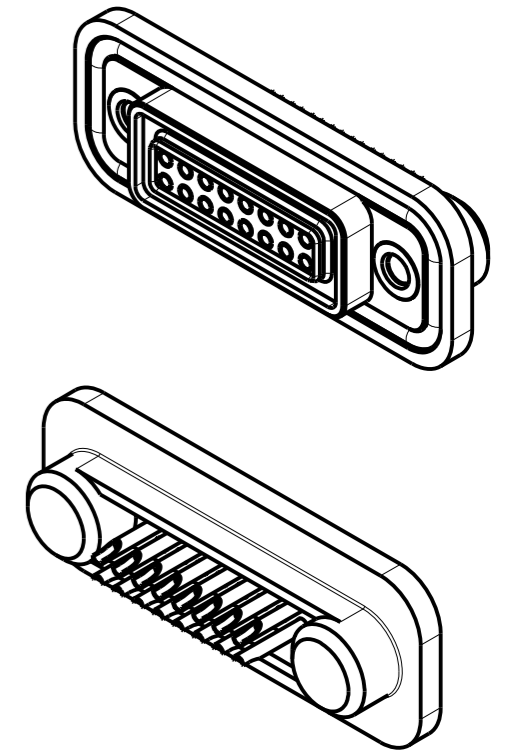
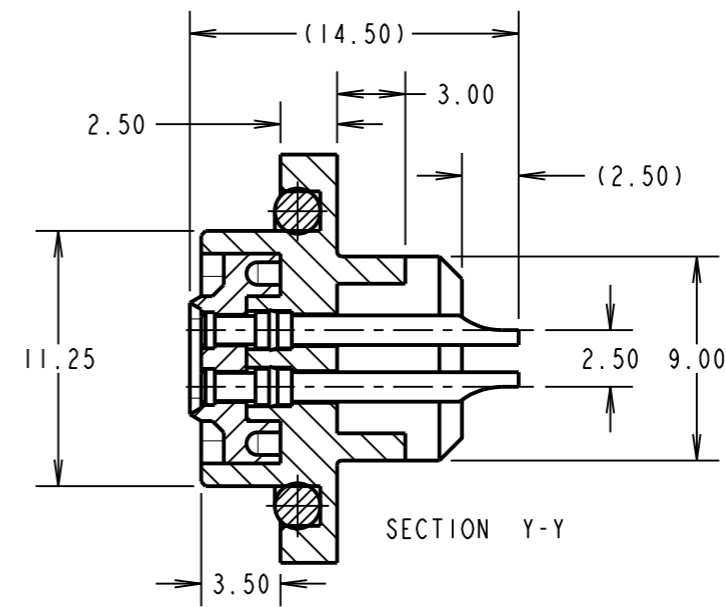
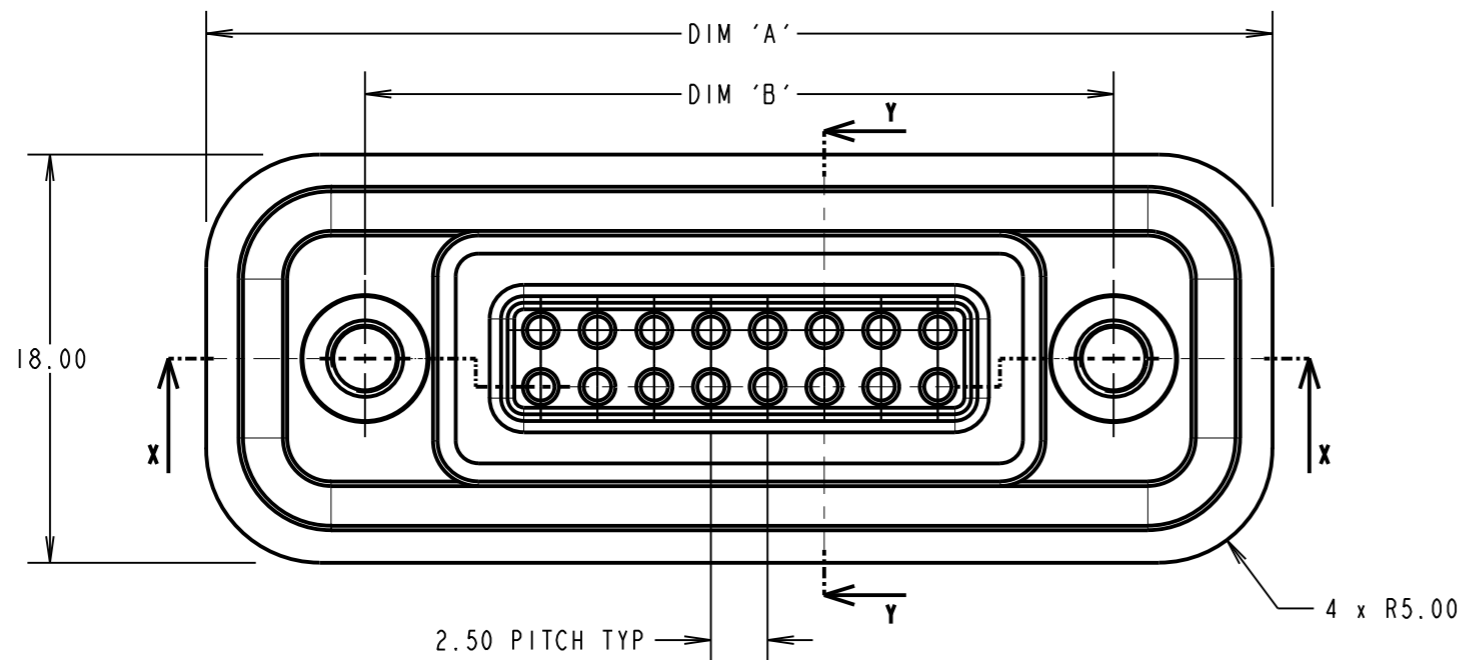

**SPECIFICATION:**

**MATERIAL:**  
 SEAL: THERMOPLASTIC ELASTOMER, 35 SHORE A, BLACK  
 O-SEAL: THERMOPLASTIC ELASTOMER, 35 SHORE A, BLACK  
 MOULDING: 30% GLASS FILLED POLYAMIDE 46, UL94V-0, BLACK  
 CONTACT: BRASS  
 THREADED INSERT: BRASS  
**FINISH:**  
 CONTACT: GOLD OVER NICKEL  
**ELECTRICAL:**  
 CONTACT RATING: 1A  
 WORKING VOLTAGE: 240V DC  
 CONTACT RESISTANCE: 10 MILLIOHMS  
 INSULATION RESISTANCE: 1000 MEGOHMS MIN AT 500V DC  
**ENVIRONMENTAL:**  
 OPERATING TEMPERATURE: -40°C TO +100°C

**NOTES:**

- DRAWING SHOWS 16-WAY CONNECTOR.
- RECOMMENDED BULKHEAD MOUNTING THICKNESS: 1.50mm.
- RECOMMENDED MOUNTING SCREWS: M3 x 6 CSK.
- SUITABLE FOR 22 AWG CABLE
- MAXIMUM TORQUE FOR M3 x 6mm CSK MOUNTING SCREWS = 80cNM  
WHEN CONNECTOR IS MOUNTED TO PANEL WITH DIAMETER 3.3 MAX FIXING HOLES.
- WHEN FULLY MATED WITH SPRING CONNECTOR, MOUNTING FLANGES WILL HAVE A GAP OF 3.5mm ±0.10mm TO ALLOW FOR PANEL THICKNESS.

SM	7	10.10.11	11489
NAME	ISS.	DATE	C/NOTE
APPROVED: S. MCCULLAGH			
CHECKED: M. G. PLESTED			
DRAWN: S.FLOWER			
CUSTOMER REF.:			
ASSEMBLY DRG:			

PART No.	No. OF WAYS	DIMENSION			
		A	B	C	D
M90-7020845	8 WAY	37.00	23.00	17.00	7.50
M90-7021645	16 WAY	47.00	33.00	27.00	17.50

**HARWIN**

www.harwin.com  
 technical@harwin.com

THIS DRAWING AND ANY INFORMATION OR DESCRIPTIVE MATTER SET OUT HEREON ARE CONFIDENTIAL AND COPYRIGHT PROPERTY OF THE HARWIN GROUP AND MUST NOT BE DISCLOSED, LOANED, COPIED OR USED FOR MANUFACTURING, TENDERING OR FOR ANY OTHER PURPOSE WITHOUT THEIR WRITTEN PERMISSION.

**TOLERANCES**  
 X. = ±1mm  
 X.X = ±0.25mm  
 X.XX = ±0.10mm  
 X.XXX = ±0.01mm  
 ANGLES = ±5°  
 UNLESS STATED

**MATERIAL:**  
 SEE SPECIFICATION  
**FINISH:**  
 S/AREA: mm<sup>2</sup>

**TITLE:**  
 FIXED CONTACT ASSEMBLY WITH 22 AWG SOLDER TAILS

**DRAWING NUMBER:**  
 M90-702XX45

SHT 2 OF 2