

Customer Information Sheet

DRAWING No.: R30-301XX02

SHEET 2 OF 2

IF IN DOUBT - ASK

©

NOT TO SCALE

THIRD ANGLE PROJECTION

ALL DIMENSIONS IN mm

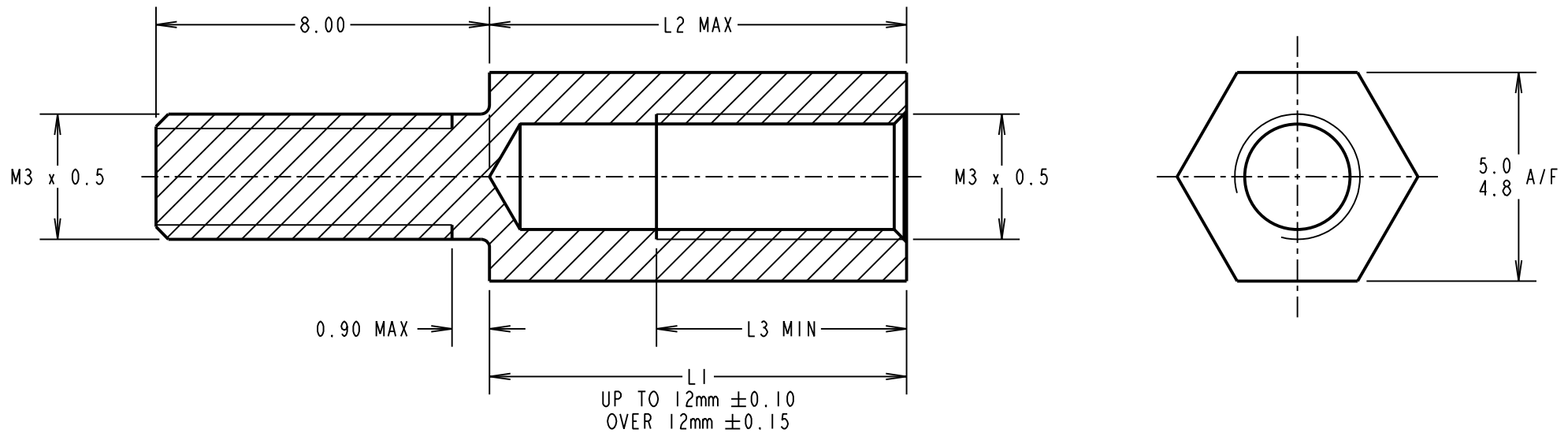

PART No.	L1	L2	L3
R30-3010402	4.00	4.0	2.50
R30-3010502	5.00	5.0	3.00
R30-3010602	6.00	6.0	4.00
R30-3010702	7.00	7.0	5.00
R30-3010802	8.00	8.0	5.00
R30-3010902	9.00	9.0	5.00
R30-3011002	10.00	10.0	5.00
R30-3011102	11.00	11.0	8.00
R30-3011202	12.00	12.0	8.00
R30-3011302	13.00	12.0	8.00
R30-3011402	14.00	12.0	8.00
R30-3011502	15.00	12.0	8.00

PART No.	L1	L2	L3
R30-3011602	16.00	12.0	8.00
R30-3011802	18.00	12.0	8.00
R30-3012002	20.00	12.0	8.00
R30-3012302	23.00	12.0	8.00
R30-3012502	25.00	12.0	8.00
R30-3012802	28.00	12.0	8.00
R30-3013002	30.00	12.0	8.00
R30-3013302	33.00	12.0	8.00
R30-3013402	34.00	12.0	8.00
R30-3013502	35.00	12.0	8.00
R30-3014002	40.00	12.0	8.00
R30-3015002	50.00	12.0	8.00

UP TO 12mm ±0.10
OVER 12mm ±0.15

ORDER CODE:

R30-301XX02

LENGTH L1 IN mm _____

TS	12	27.11.14	12692
NAME	ISS.	DATE	C/NOTE
APPROVED: T. SAUNDERS			
CHECKED: S. BENNETT			
DRAWN: WJ BOURNE			
CUSTOMER REF.:			
ASSEMBLY DRG:			

HARWIN

www.harwin.com
technical@harwin.com

THIS DRAWING AND ANY INFORMATION OR DESCRIPTIVE MATTER SET OUT HEREON ARE CONFIDENTIAL AND COPYRIGHT PROPERTY OF THE HARWIN GROUP AND MUST NOT BE DISCLOSED, LOANED, COPIED OR USED FOR MANUFACTURING, TENDERING OR FOR ANY OTHER PURPOSE WITHOUT THEIR WRITTEN PERMISSION.

TOLERANCES

X. = ±1mm
X.X = ±0.50mm
X.XX = ±0.10mm
X.XXX = ±0.01mm

ANGLES = ±5°
UNLESS STATED

MATERIAL:

BRASS CW614N M TO BS EN 12164
(CuZn39Pb3)

FINISH: NICKEL

S/AREA: mm²

TITLE:

M3 HEXAGONAL
MALE/FEMALE SPACER

DRAWING NUMBER:

R30-301XX02

SHT
2 OF 2