

# Customer Information Sheet

DRAWING No.: R30-940XX00

SHEET 2 OF 2

IF IN DOUBT - ASK

©

NOT TO SCALE

THIRD ANGLE PROJECTION

ALL DIMENSIONS IN mm

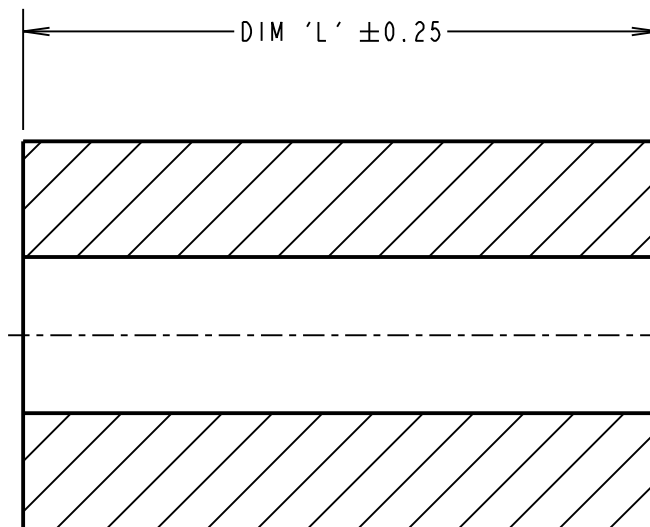

SECTION Z-Z

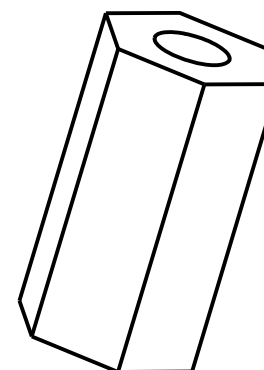
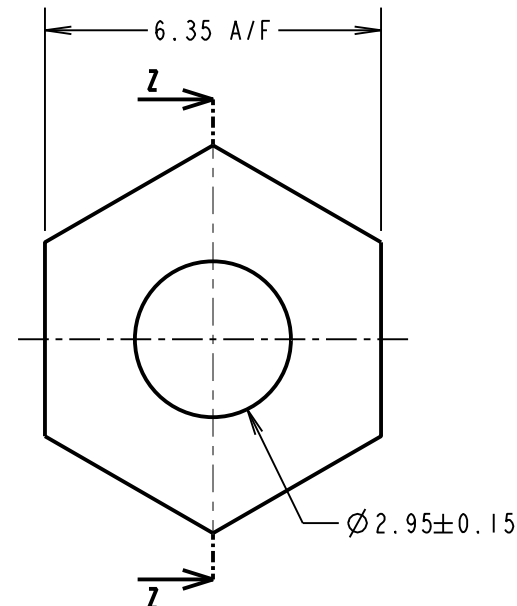

NOTES:  
1. SPACER SUITED TO M3 SELF-TAPPING SCREW.

PART No.	DIM 'L'
R30-9400300	3.00
R30-9400400	4.00
R30-9400500	5.00
R30-9400600	6.00
R30-9400700	7.00
R30-9400800	8.00
R30-9400900	9.00
R30-9401000	10.00
R30-9401100	11.00
R30-9401200	12.00
R30-9401300	13.00
R30-9401400	14.00
R30-9401500	15.00
R30-9401600	16.00
R30-9401800	18.00
R30-9402000	20.00
R30-9402500	25.00

SF	6	19.07.13	12157
NAME	ISS.	DATE	C/NOTE
APPROVED:		S.FLOWER	
CHECKED:		S.BENNETT	
DRAWN:		D.BECK	
CUSTOMER REF.:			
ASSEMBLY DRG:			

## HARWIN

www.harwin.com  
technical@harwin.com

THIS DRAWING AND ANY INFORMATION OR DESCRIPTIVE MATTER SET OUT HEREON ARE CONFIDENTIAL AND COPYRIGHT PROPERTY OF THE HARWIN GROUP AND MUST NOT BE DISCLOSED, LOANED, COPIED OR USED FOR MANUFACTURING, TENDERING OR FOR ANY OTHER PURPOSE WITHOUT THEIR WRITTEN PERMISSION.

TOLERANCES  
X. = ±1mm  
X.X = ±0.25mm  
X.XX = ±0.10mm  
X.XXX = ±0.01mm  
ANGLES = ±5°  
UNLESS STATED

MATERIAL:  
30% GLASS-FILLED PBT  
BLACK, UL94V-0  
FINISH: CLEAN  
S/AREA: mm<sup>2</sup>

TITLE:  
M3 HEXAGONAL  
THREADED SPACER  
DRAWING NUMBER:  
**R30-940XX00**

SHT  
2 OF 2