

# Customer Information Sheet

DRAWING No.: S0941-46R

SHEET 2 OF 2

IF IN DOUBT - ASK

©

NOT TO SCALE

THIRD ANGLE PROJECTION

ALL DIMENSIONS IN mm

**SPECIFICATION:**

**MATERIAL:**  
CONTACT = STAINLESS STEEL, 0.15mm THICK

**FINISH:**  
1.0µm - 3.0µm TIN OVER 0.4µm - 1.5µm NICKEL

**ELECTRICAL:**  
RESISTANCE = 100mΩ MAX

**MECHANICAL:**  
INSERTION FORCE = 9.8N MAX  
WITHDRAWAL FORCE = 0.69N MIN

**ENVIRONMENTAL:**  
OPERATING TEMPERATURE = -40°C TO +85°C  
STORAGE TEMPERATURE = -40°C TO +85°C

**SOLDERING DATA:**  
SOLDERING HEAT RESISTANCE = 250°C FOR 5 SECONDS

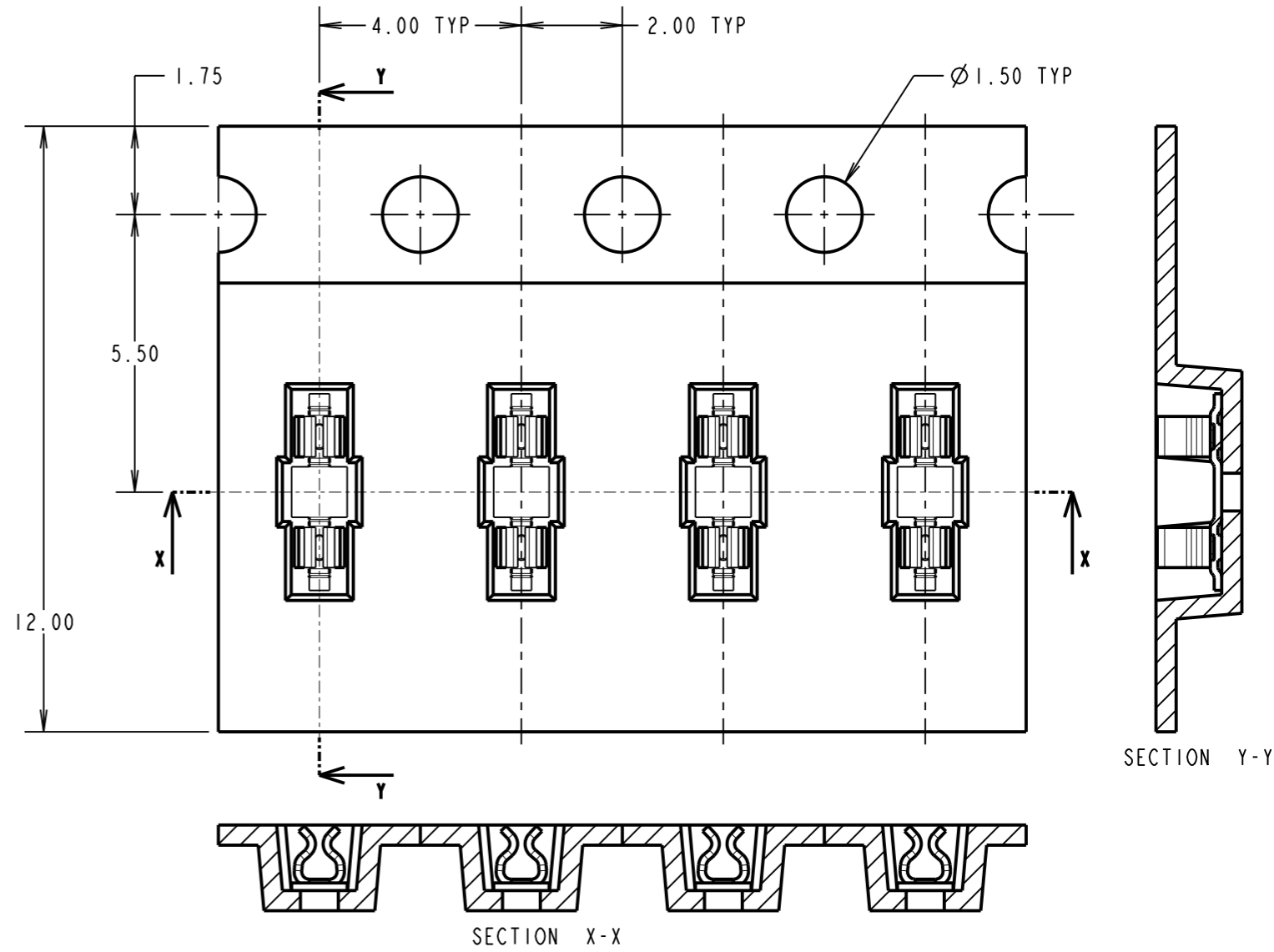
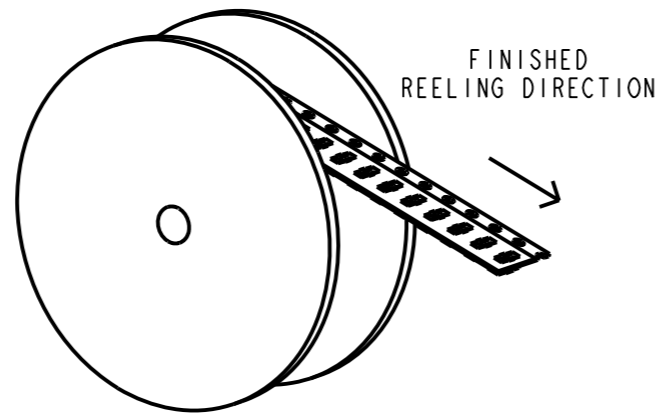

**NOTES:**  
1. FOR USE WITH 0.15 - 0.20mm THICK SHIELD CANS.  
2. QUANTITY PER REEL = 10,000.

RECOMMENDED PCB LAYOUT  
(TOLERANCE = ±0.05)

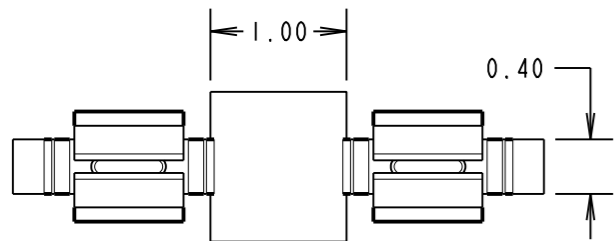
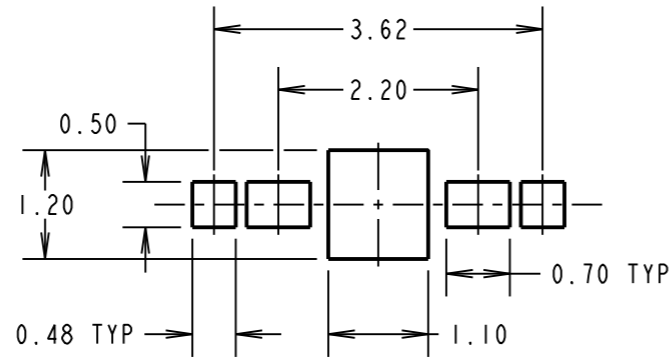

COMPONENT DETAILS

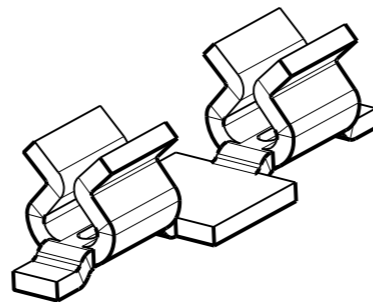
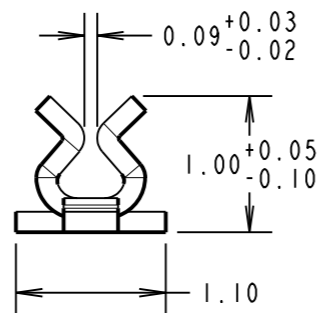
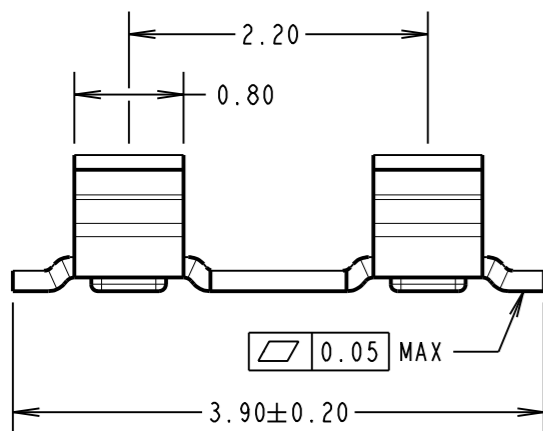

REEL DETAILS

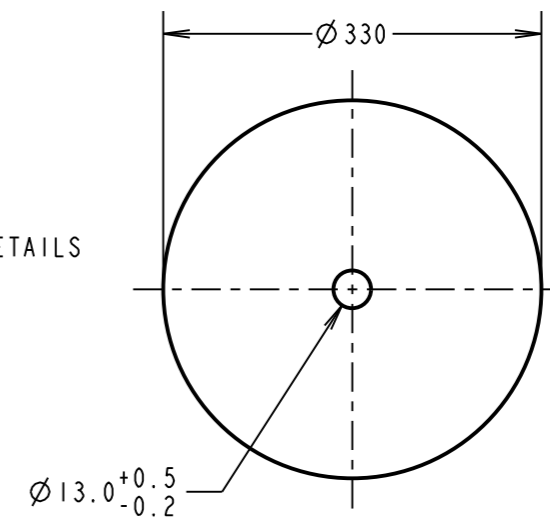

SB	1	14.04.15	-----
NAME	ISS.	DATE	C/NOTE
APPROVED:		S.BENNETT	
CHECKED:		M.PLESTED	
DRAWN:		S.BENNETT	
CUSTOMER REF.:			
ASSEMBLY DRG:			

**HARWIN**

www.harwin.com  
technical@harwin.com

THIS DRAWING AND ANY INFORMATION OR DESCRIPTIVE MATTER SET OUT HEREON ARE CONFIDENTIAL AND COPYRIGHT PROPERTY OF THE HARWIN GROUP AND MUST NOT BE DISCLOSED, LOANED, COPIED OR USED FOR MANUFACTURING, TENDERING OR FOR ANY OTHER PURPOSE WITHOUT THEIR WRITTEN PERMISSION.

**TOLERANCES**  
X. = ±1mm  
X.X = ±0.50mm  
X.XX = ±0.10mm  
X.XXX = ±0.01mm  
ANGLES = ±5°  
UNLESS STATED

**MATERIAL:**  
SEE ABOVE

**FINISH:**  
SEE ABOVE

**S/AREA:**  
mm<sup>2</sup>

**TITLE:**  
SMT RFI SHIELD CLIP  
IN TAPE AND REEL

**DRAWING NUMBER:**  
S0941-46R

SHT 2 OF 2