

Customer Information Sheet

DRAWING No.: W2630-00

IF IN DOUBT - ASK

©

NOT TO SCALE

THIRD ANGLE PROJECTION

ALL DIMENSIONS IN mm

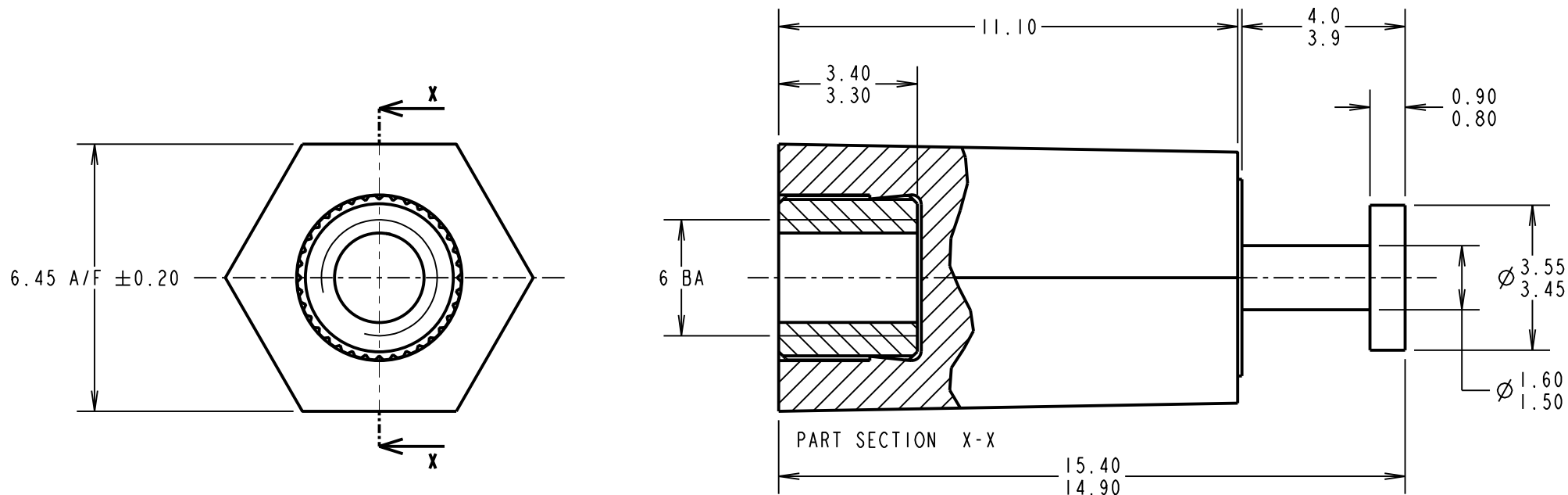

SPECIFICATIONS:

MATERIAL:

INSULATOR = POLYAMIDE 46, BLACK

INSERTS = BRASS

FINISH:

BOTTOM THREAD INSERT = 1.25µ NICKEL

SINGLE TURRET INSERT = 7.6µ 100% TIN OVER 2.4µ NICKEL

ELECTRICAL:

CURRENT RATING = 10A MAX

VOLTAGE PROOF = 10kV MIN

ENVIRONMENTAL:

OPERATING TEMPERATURE = -55°C TO +125°C

SM	8	08.02.11	11115
NAME	ISS.	DATE	C/NOTE
APPROVED: S. MCCULLAGH			
CHECKED: M. G. PLESTED			
DRAWN: K. SHIER			
CUSTOMER REF.:			
ASSEMBLY DRG:			

HARWIN

www.harwin.com
technical@harwin.com

THIS DRAWING AND ANY INFORMATION OR DESCRIPTIVE MATTER SET OUT HEREON ARE CONFIDENTIAL AND COPYRIGHT PROPERTY OF THE HARWIN GROUP AND MUST NOT BE DISCLOSED, LOANED, COPIED OR USED FOR MANUFACTURING, TENDERING OR FOR ANY OTHER PURPOSE WITHOUT THEIR WRITTEN PERMISSION.

TOLERANCES

X. = ±1mm
X.X = ±0.25mm
X.XX = ±0.10mm
X.XXX = ±0.01mm
ANGLES = ±5°
UNLESS STATED

MATERIAL:

SEE ABOVE

FINISH: SEE ABOVE

S/AREA: mm²

TITLE:

INSULATED TERMINAL
SINGLE TURRET

DRAWING NUMBER:

W2630-00

SHT
2 OF 2