

Ultra Low Profile Power Resistors

WDBR Series

- Ultra low profile thick-film on steel
- 500W to 7kW peak power
- Single fixing heatsink mountable
- Ideal for dynamic braking, inrush limit and snubber circuits
- Choice of flying lead, push-on or solder terminations
- Low inductance design
- High isolation, even after failsafe overload fusing
- RoHS compliant, non-flammable construction

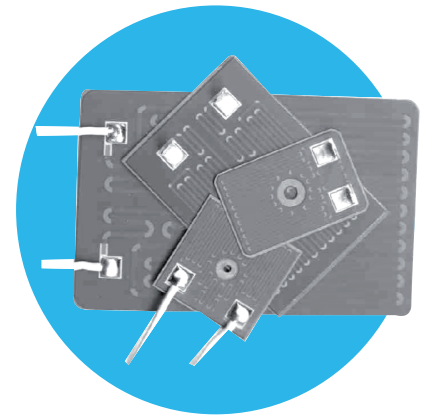

All Pb-free parts comply with EU Directive 2011/65/EU (RoHS2)

Electrical Data

		WDBR1/2	WDBR1	WDBR2	WDBR3	WDBR5	WDBR7
Resistance range	ohms	12, 15, 20, 22, 25, 47, 50, 100	12, 15, 20, 22, 25, 47, 50, 100, 150				
Resistance tolerance	%	10					
Pulse power rating ¹	kW	0.5	1.5	2.0	3.5	5.0	7.0
Power rating on heatsink ²	W	160	180	200	260	270	280
Power rating on fan-cooled heatsink ³	W	300	700	780	900	1000	1490
TCR	ppm/°C	< +600					
Maximum element temperature	°C	365					
Ambient temperature range (heatsink)	°C	-55 to +200					
Dielectric withstand ⁴	V (dc/ac peak)	2500					
Inductance (typical)	µH	<3		<4	<5	<6	

Notes:

1. For details of pulse condition see Fig. 1 in Performance Data.
2. Mounted on a 0.53°C/W heatsink with no forced air cooling, air temperature 25°C.
3. Mounted on a 0.53°C/W heatsink with 5m/s forced air cooling, air temperature 25°C.
4. Based on 100% production test, duration 2s minimum

Physical Data

Dimensions in mm, weight without terminations in g								
	L ±0.1	W ±0.1	t ±0.1	∅D nom	a nom	b nom	c nom	Wt. nom
WDBR1/2	31.9	28.1	0.9	2.2	7.5	3.1	4.3	6.5
WDBR1	49.3	35.9		3.2	3.2	11.2	6.2	12.6
WDBR2	61	40.6		4.7	13.0	5.8	17.1	
WDBR3	101.6	70		5.3	13.5	22.0	10.2	50.8
WDBR5	122	70	1.5	14.0	23.8	7.4	60.7	
WDBR7	152.4	101.6		15.0	51.3	9.2	181.8	

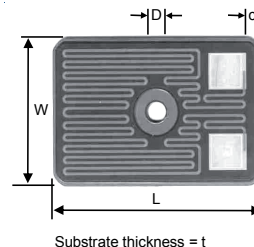

Fixing hole is located centrally except on WDBR1/2 where the dimension from the edge by the terminations to the mounting hole centre is 16.68mm.

In addition to the central fixing hole, WDBR7 has two corner holes. These are present for manufacturing purposes only and should not be used as fixing holes.

Construction

A high integrity dielectric layer is applied to a machined stainless steel substrate. Thick-film conductor and resistor patterns are printed and fired, then protected with a high temperature overglaze. The termination pads are tinned with solder and optional terminals or leads are soldered on.

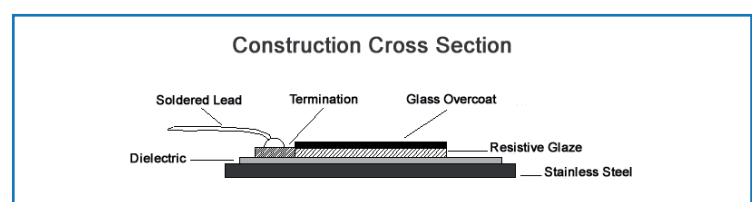

General Note

TT Electronics reserves the right to make changes in product specification without notice or liability. All information is subject to TT Electronics' own data and is considered accurate at time of going to print.

WDBR Series

Terminations

The following termination options are available

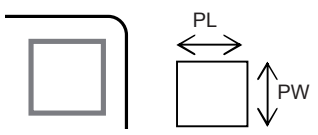
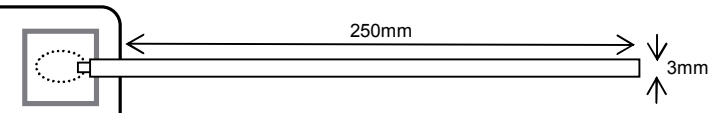
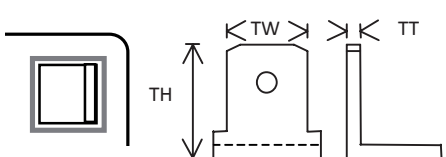
Option	Code	Nominal Dimensions (mm)													
Solder pad only ¹	I		<table border="1"> <tr> <td>WDBR Size</td> <td>½</td> <td>1, 2, 3, 5 & 7</td> </tr> <tr> <td>Pad Length, PL</td> <td>7.5</td> <td>9.0</td> </tr> <tr> <td>Pad Width, PW</td> <td>4.5</td> <td>9.0</td> </tr> </table>	WDBR Size	½	1, 2, 3, 5 & 7	Pad Length, PL	7.5	9.0	Pad Width, PW	4.5	9.0			
			WDBR Size	½	1, 2, 3, 5 & 7										
Pad Length, PL	7.5	9.0													
Pad Width, PW	4.5	9.0													
Flying leads UL3134/5 40A, 600V	L														
Push-on connectors	T		<table border="1"> <tr> <td>WDBR Size</td> <td>½</td> <td>1, 2, 3, 5 & 7</td> </tr> <tr> <td>Terminal Height, TH</td> <td>6.8</td> <td>11</td> </tr> <tr> <td>Terminal Width, TW</td> <td>2.8</td> <td>6.3</td> </tr> <tr> <td>Terminal Thickness, TT</td> <td>0.8</td> <td>0.8</td> </tr> </table>	WDBR Size	½	1, 2, 3, 5 & 7	Terminal Height, TH	6.8	11	Terminal Width, TW	2.8	6.3	Terminal Thickness, TT	0.8	0.8
			WDBR Size	½	1, 2, 3, 5 & 7										
Terminal Height, TH	6.8	11													
Terminal Width, TW	2.8	6.3													
Terminal Thickness, TT	0.8	0.8													

Notes:

1. Two options exist for solder type. The standard is SnAg (96SC) which is Pb-free and the second (HT) is high temperature HMP alloy which is Pb-bearing. Both are RoHS compliant, but the second relies on the RoHS exemption for high temperature solders and is targeted at specialist high temperature applications.

Thermal Performance

	ΔR%	Maximum
Pulsed load at full pulse power rating 50,000 cycles (see Fig 1) Mounted on a 0.53°C/W heatsink with 5m/s forced air cooling, air temperature 25°C.		5
Derating at heatsink temperatures >160°C		See Fig. 2

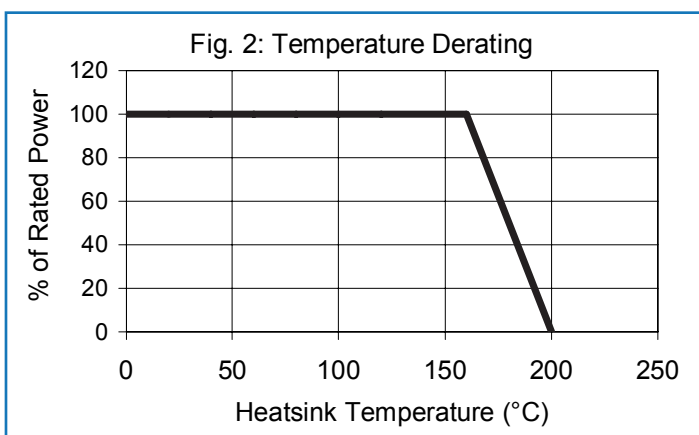
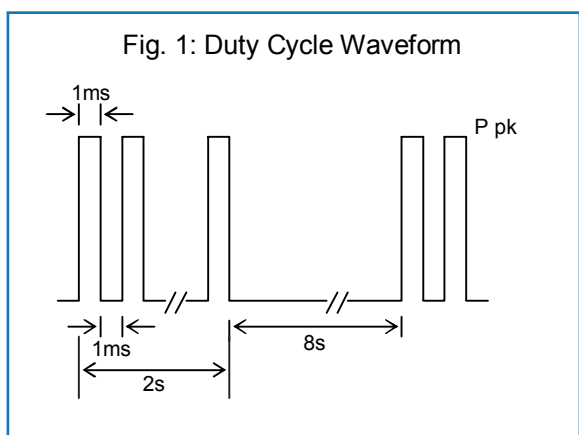

General Note

TT Electronics reserves the right to make changes in product specification without notice or liability. All information is subject to TT Electronics' own data and is considered accurate at time of going to print.

WDBR Series

Application Notes

A heatsink with thermal resistance $\leq 0.53^{\circ}\text{C}/\text{W}$ will enable the component to operate at its continuous power rating. Thermal grease (e.g. Dow Corning DC340) should be used and the heatsink should have a surface finish of $<6.3\mu\text{m}$ with flatness of $<0.05\text{mm}$. The resistor should be mounted using an appropriate bolt as listed in the table below. This should be tightened so as to bring the whole area of the steel substrate into intimate contact with the heatsink. The unmounted part is slightly bowed so that the centre is above the edges. Inadequate tightening will leave the centre out of contact with the heatsink, whilst over tightening can cause the edges to rise. The tightening torque required will depend on the fixings and heatsink used, but typical figures are given for guidance. WDBR resistors will fail safe (open circuit) under overload fault conditions and still maintain a 1kV dielectric withstand.

	Bolt Size	Typical Tightening Torque (Nm)
WDBR1/2	M2	0.6
WDBR1	M3	2
WDBR2	M5	2.5
WDBR3	M5	2.5
WDBR5	M5	3.5
WDBR7	M5	4

WDBR resistors may be customised in various ways including:

- Alternative shapes and dimensions up to 406mm x 406mm
- Integration of temperature measurement elements
- Alternative ohmic values, tolerance & TCR
- Increased dielectric withstand voltage
- Custom braking resistors with UL approval

For a full Applications Note for dynamic braking see http://www.welwyn-tt.com/pdf/application_notes/WDBR.pdf

Overload Conditions

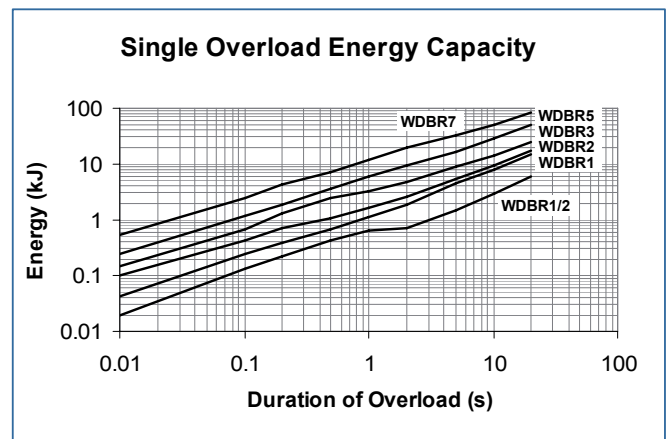
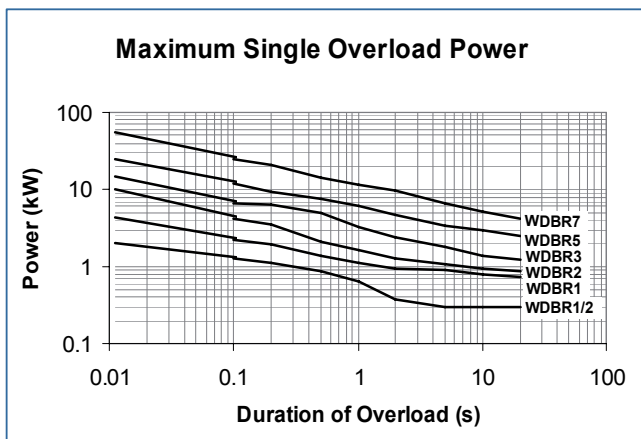

Maximum peak current (A)

Value (ohms)	12	15	20	22	25	47	50	100	150
WDBR1/2	15.2	15.2	7.6	7.6	7.6	7.6	7.6	7.6	
WDBR1	21.6	21.6	21.6	8.3	8.3	8.3	8.3	8.3	8.3
WDBR2	20.3	20.3	7.6	7.6	7.6	7.6	7.6	7.6	7.6
WDBR3	25.4	25.4	25.4	25.4	11.4	11.4	11.4	11.4	11.4
WDBR5	25.4	25.4	25.4	25.4	25.4	10.2	10.2	10.2	10.2
WDBR7	44.5	44.5	44.5	44.5	44.5	20.3	20.3	20.3	20.3

General Note

TT Electronics reserves the right to make changes in product specification without notice or liability.

All information is subject to TT Electronics' own data and is considered accurate at time of going to print.

WDBR Series

Ordering Procedure

Example: WDBR2 at 100 ohms and 10% tolerance with standard solder, flying leads and packed in a box of 40 pieces:

WDBR2-100RKLW

Type _____

Solder Option _____

	96SC	Standard
HT	HMP	High temperature

Value (use IEC62 code) _____

Tolerance (use IEC62 code) _____

K	10%
---	-----

Termination _____

I	Solder pad only
L	Flying leads
T	Push-on connectors

Packing _____

W	WDBR1/2I	Bulk	180/box	Standard
	WDBR1/2T		64/box	
	WDBR1/2L, WDBR1L, WDBR2L, WDBR3I, WDBR3T, WDBR5I, WDBR5T		40/box	
	WDBR1I, WDBR2I		100/box	
	WDBR1T, WDBR2T		80/box	
	WDBR3L, WDBR5L, WDBR7 all terminations		20/box	

General Note

TT Electronics reserves the right to make changes in product specification without notice or liability. All information is subject to TT Electronics' own data and is considered accurate at time of going to print.