

MS-Series

CIRCUIT BREAKER

Designed and tested to operate flawlessly in the harshest of environments, the MS-Series sealed toggle circuit breaker is ideally suited for COTS (commercial off the shelf) military applications. Our space saving envelope meets IP68 requirements and features a durable metal and sealed mounting bushing with MIL-PRF-39019F ingress protection when mounted in a panel.

This class-leading, affordable circuit breaker was designed in accordance with the requirements of MIL-PRF-55629 and MIL STD 202, making it the best choice for those applications where shock, vibration, moisture resistance, salt spray and thermal shock are of the utmost consideration. The MS-Series' compact size and reliability make it ideal for crucial communication equipment and other mission critical components.

1-3 poles; 0.02-30 amps; 65VDC, 240VAC, 120/240VAC; UL, cUL recognized & TUV pending.

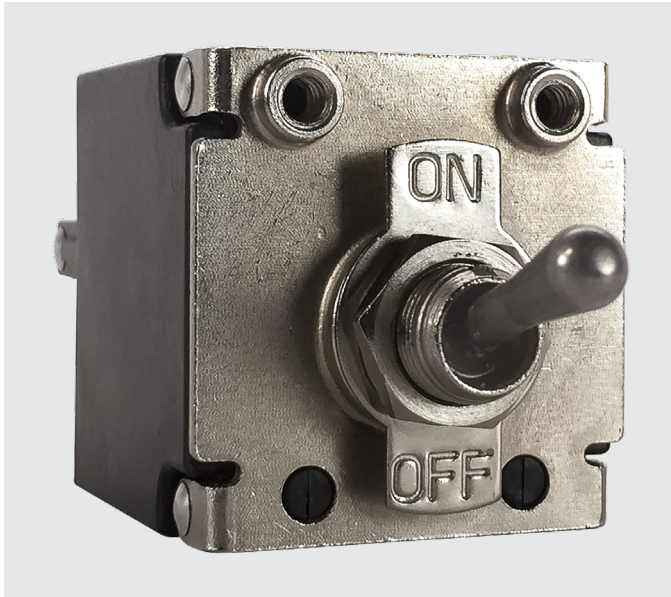

Resources:

[Download 3D CAD Files](#)



[Watch Product Video](#)



Product Highlights:

- ♦ Sealed Toggle Actuator
- ♦ MIL-PRF-39019F Ingress Protection
- ♦ MIL-PRF-55629 and MIL STD 202 Compliant
- ♦ Compact Design

Typical Applications:

- ♦ COTS Military
 - Communication Equipment
- ♦ Off Highway Equipment
 - Construction, Mining & Agriculture
- ♦ Generators & Power Supplies
- ♦ Harsh Environment Applications



Carling Technologies™

Innovative Designs. Powerful Solutions.

Carling Technologies, Inc.
60 Johnson Avenue, Plainville, CT 06062
Email: sales@carlingtech.com
Application Support: team2@carlingtech.com
Phone: 860.793.9281 Fax: 860.793.9231

www.carlingtech.com

MS-Series

DESIGN FEATURES

SEALS

IP68 Designed and tested to comply with MIL-PRF-39019F Ingress Protection

COMPACT SIZE

Max performance in compact size: 0.20-30 Amps; 65 VDC, 240 VAC 120/240 VAC

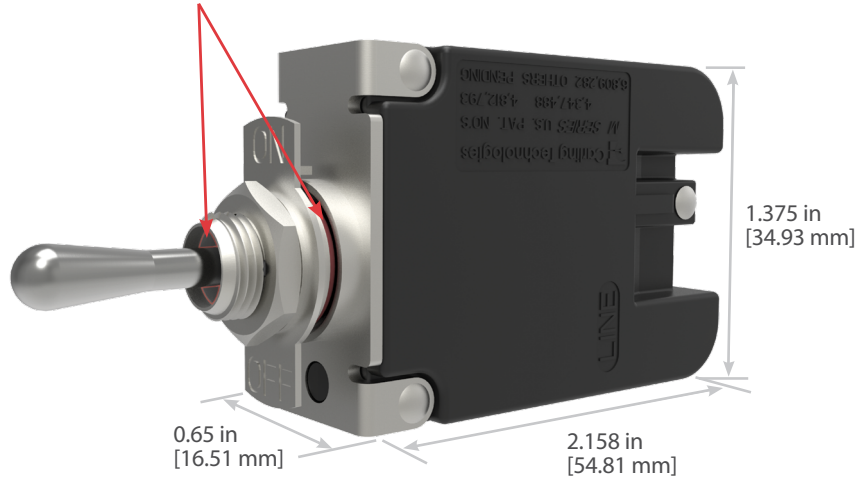

TERMINAL BARRIERS

Meet UL 1077 Spacing Requirements

OPTIONAL AUXILIARY SWITCH

Provides Breaker Status Indication

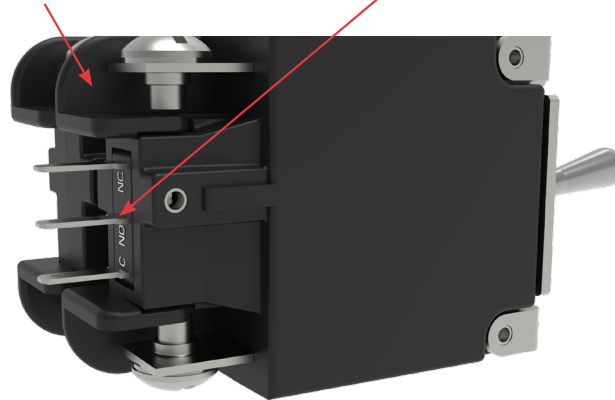

Electrical Table

Table A: Lists UL & cUL Configuration & Performance Capabilities

MS-SERIES TABLE A: COMPONENT SUPPLEMENTARY PROTECTORS							
Circuit Configuration	Voltage			Current Rating		Short Circuit Capacity (Amps) ¹	
	Max Rating	Frequency	Phase	General Purpose Amps	Poles Breaking	UL / cUL	
						U1	U3
Series	65	DC	---	0.02 - 30	1	3000	300
	240	50 / 60	1	0.02 - 30	1, 2	2000	300
	120 / 240	50 / 60	1	0.02 - 30	2 or 3	2000	300

Notes:

¹ Short Circuit Current Rating (SC) Codes — The short-circuit current rating, followed by a letter and number designating the test conditions and any calibration following the short-circuit test as defined below:

U - Indicates that the short circuit test was performed without a series fuse

1 - Indicates that a re-calibration was not performed as part of the short circuit testing

3 - Indicates that the protector has proven to be suitable for further use after the short circuit test

Re-calibration, dielectric strength and voltage withstand tests were performed after the short circuit testing

Electrical

Current Ratings .02 - 30 Amps
 Voltage Rating 65VDC, 240VAC, 120/240VAC
 Dielectric Strength Withstand 1500VAC, 50/60Hz for one minute
 Insulation Resistance Minimum of 100 Megohms @ 500VDC
 Operating Frequency 50/60 Hz, DC
 Overload 50 operations
 Interrupt Capacity See Table A
 Auxiliary Switch Silver contacts: Resistive. 5A/125VAC, 3A/32VDC, 7A/28VDC, 0.5A/50VDC lamp load. Gold plated contacts: Resistive. 0.1A/125VAC, 0.1A/32VDC
 Endurance 10,000 make and break operations @ 6 per minute, at rated current & voltage, Per MIL-PRF-55629

Impedance

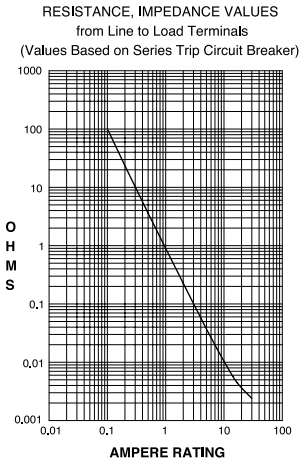

CURRENT (AMPS)	TOLERANCE (%)
0.20 - 30.0	25%

Physical

Number of Poles 1-3 poles
 Terminals 0.25" Quick Connect, 0.25" Solder Lug, #8-32 or M4 Screw. Auxiliary Switch Terminals: 0.110" Tab QC 3/8-32 UNEF-2A thread 6/32 UNC-2B thread multi-pole only
 Mounting Toggle
 Actuator Maximum operating force in either direction:
 Actuation Force One-pole breaker – 4 pounds
 Two-pole breaker – 7 pounds
 Three-pole breaker – 10 pounds
 Appearance All surfaces above panel do not reflect light
 Weight Approximately 1.8 oz (50g) per pole

Mechanical

Trip Free Trips on short circuit, overload, even when actuator is forcibly held in the "On" position.
 Trip Indication The operating toggle moves positively to the "OFF" position when an overload or short circuit causes the circuit breaker to trip.

Environmental

Designed in accordance with requirements of MIL-STD-202G as following:

Shock Withstands 100 G's, 6ms saw tooth while carrying rated current per MIL-STD-202G Method 213, Test Condition I. Instantaneous and ultra-short curves tested at 80% of rated current.
 Vibration Withstands 0.060" excursion from 10-55 Hz, and 10 G's 55-500Hz, at rated current per MIL-STD-202G Method 204, Test Condition A. Instantaneous and ultra-short curves tested at 80% of rated current.
 Salt Atmosphere MIL-STD-202G Method 101E, Condition A (90-95% RH@ 5% NaCl Solution, 96 hours.)
 Moisture Resistance MIL-STD-202G Method 106, 10-24 Hour Cycles, 25 - 65C, 80-100% RH
 Thermal Shock MIL-STD-202G Method 107, Condition A, 5 cycles; -55C to +25C to +85C to +25C
 Operating Temperature -40 °C to +85 °C
 High & Low Temperature Per MIL-PRF-55629, Section 3.12 & 4.8.8. -40 to 85 C
 Panel Seal Per MIL-PRF-55629, Section 3.24 & 4.8.20. When mounted to a panel, the portion above the panel shall withstand 15 PSI air pressure without leakage for 30 minutes in both directions
 Chemical Resistance Only the outside surface of the case and the handles may be cleaned with detergents or alcohol. Organic (hydro-carbon based) solvents are not recommended because they attack plastics. Caution should be taken when solvents are used to clean and remove flux from terminals. Lubricants should not be introduced into the toggle/bushing openings.
 Fluxes Only non-corrosive fluxes are used for soldering and/or brazing.
 Other Materials used in this product are non-nutrient to fungus growth. Materials are selected to prevent electrolytic corrosion between adjacent components.

Agency Certifications

UL1077, cUL C22.2 No. 235-04
 IEC60934 pending

*Manufacturer reserves the right to change product specification without prior notice.

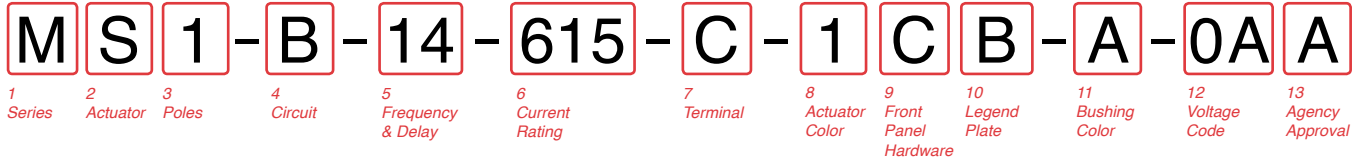

1 SERIES
M

2 ACTUATOR
S Sealed Toggle

3 POLES
1 One **2** Two **3** Three

4 CIRCUIT
A Switch Only (no coil)^{1,2}
B Series Trip (current)
M Series Trip (current) Aux switch .110 QC x 0.20 QC (silver contacts)
9 Series Trip (current) Aux switch .110 QC x 0.20 QC (gold contacts)

5 FREQUENCY & DELAY

03 DC, 50/60 Hz, Switch Only ¹	32 DC, 50/60 Hz Short
10 DC, Instantaneous	34 DC, 50/60 Hz Medium
12 DC, Short	62 50/60 Hz Short, Hi-Inrush ⁴
14 DC, Medium	64 50/60 Hz Medium, Hi-Inrush ⁴
20 50/60 Hz Instantaneous	72 DC, Short, High-Inrush ⁴
22 50/60 Hz Short	74 DC, Medium, High-Inrush ⁴
24 50/60 Hz Medium	92 DC, 50/60 Hz Short, Hi-Inrush ⁴
30 DC, 50/60 Hz Instantaneous	94 DC, 50/60 Hz Medium, In-rush ⁴

6 CURRENT RATING (AMPERES)

CODE	AMPERES	CODE	AMPERES	CODE	AMPERES
020	0.020	225	0.250	420	2.000
025	0.025	230	0.300	522	2.250
030	0.030	235	0.350	425	2.500
035	0.035	240	0.400	527	2.750
040	0.040	245	0.450	430	3.000
045	0.045	250	0.500	435	3.500
050	0.050	255	0.550	440	4.000
055	0.055	260	0.600	445	4.500
060	0.060	265	0.650	450	5.000
065	0.065	270	0.700	455	5.500
070	0.070	275	0.750	460	6.000
075	0.075	280	0.800	465	6.500
080	0.080	285	0.850	470	7.000
085	0.085	290	0.900	475	7.500
090	0.090	295	0.950	480	8.000
095	0.095	410	1.000	485	8.500
210	0.100	512	1.250	490	9.000
215	0.215	415	1.500	495	9.500
220	0.200	517	1.750	610	10.00

7 TERMINAL
1 Push-On 0.250 Tab (QC)
2 Screw 8-32 (Upturned Lugs)
3 Screw 8-32 (Bus Type)
C Screw Terminal M4 (Upturned Lugs)
E Screw Terminal M4 (Bus Type)
L Solder Lug

8 ACTUATOR & MARKING COLOR
1 Dull Metallic

9 FRONT PANEL HARDWARE
A No Outer Panel Hardware
B Hex Nut, Nickel Plated
C Hex Nut, Nickel Plated with Locking Ring
F Panel Dress Nut, Nickel Plated
G Panel Dress Nut, Nickel Plated with Locking Ring

10 LEGEND PLATE
A No Legend Plate
B On-Off Vertical
C On-Off Horizontal
D I-O Vertical
E I-O Horizontal
F Dual Vertical
G Dual Horizontal

11 BUSHING COLOR
A Nickel Plated / Multipole Version

12 VOLTAGE CODE
0A 65 VDC
0D 240 VAC
0C 120/240 VAC³
0N 65 VDC / 120/240 VAC³
17 65 VDC / 240 VAC

13 AGENCY APPROVAL
A Without approvals
B UL Recognized
C UL & cUL Recognized

Notes:
 1 Series code "A" only available with delay code "03"
 2 Only available with agency approvals when tied to a protected pole
 3 Requires a 2 or 3 pole device
 4 Only available without agency approvals (Approval Code A)

Form & Fit

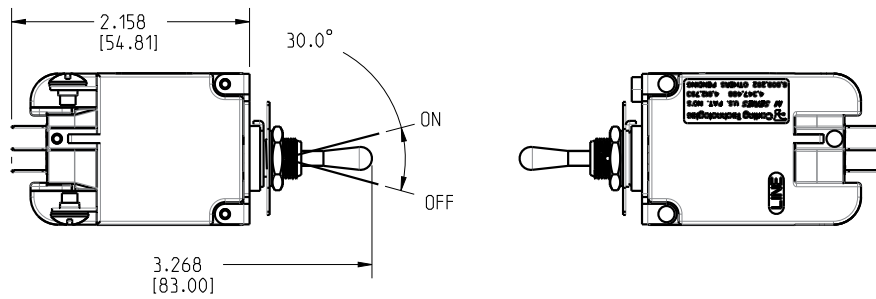
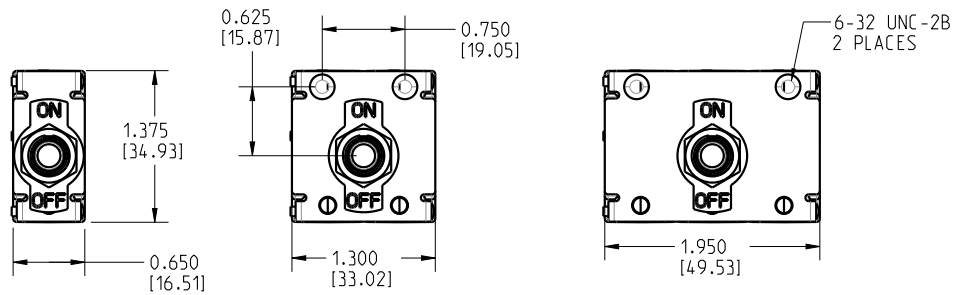

.375-32 UNEF-2A THREAD

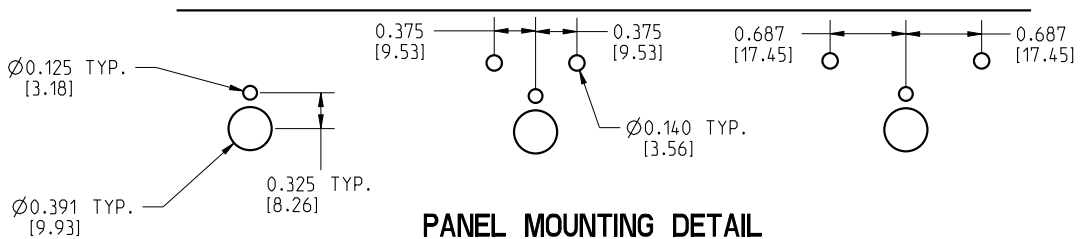
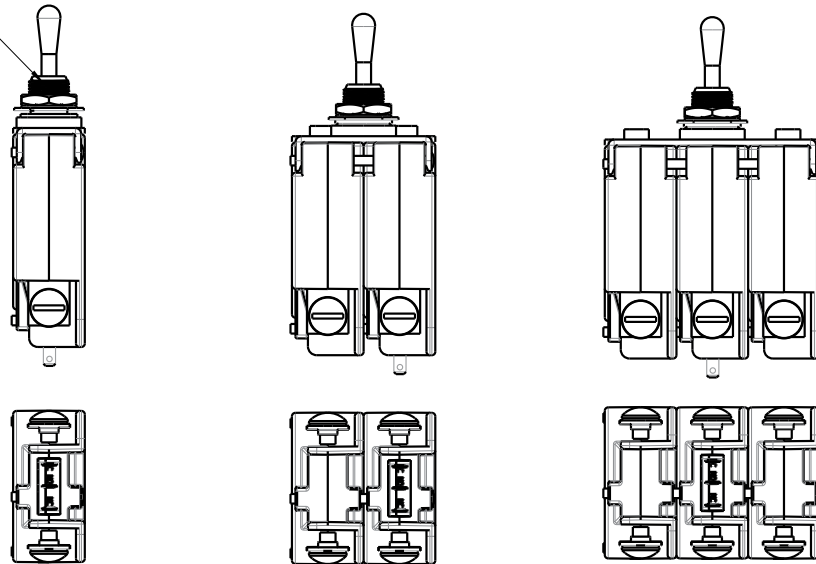

**PANEL MOUNTING DETAIL
PANEL THICKNESS 0.125" TO 0.156"**

- Notes:
 1 All dimensions are in inches [millimeters].
 2 Tolerance ± 0.020 [51] unless otherwise specified.

Delay Curve

Dual Rated AC/DC

Instantaneous

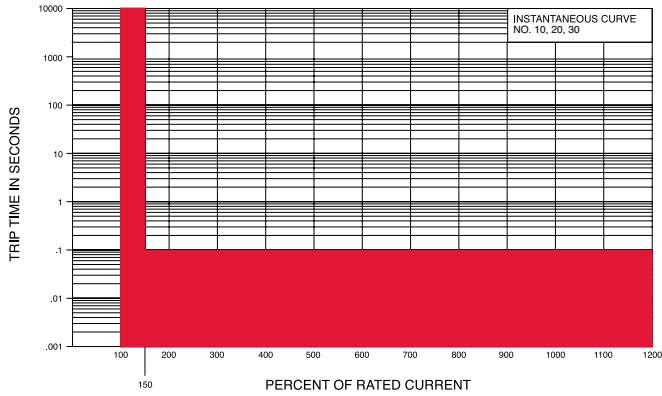

Short

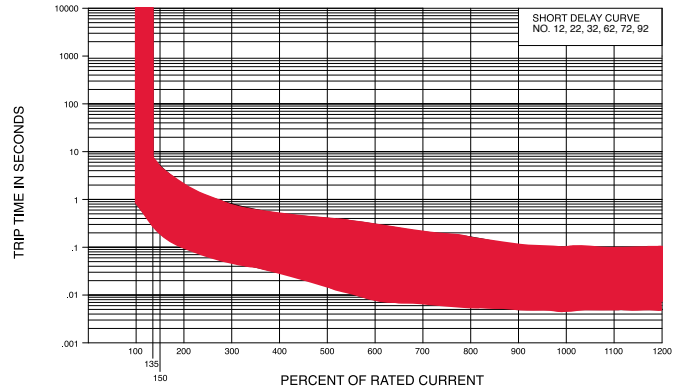

Medium

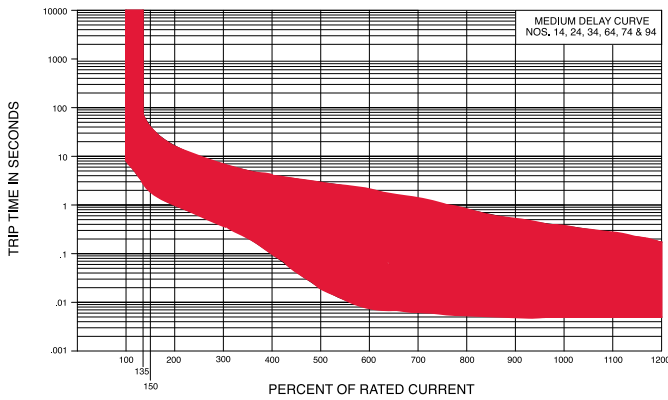

Authorized Sales Representatives

Click on the group name on the map below to find your local representative or visit www.carlingtech.com/findarep.

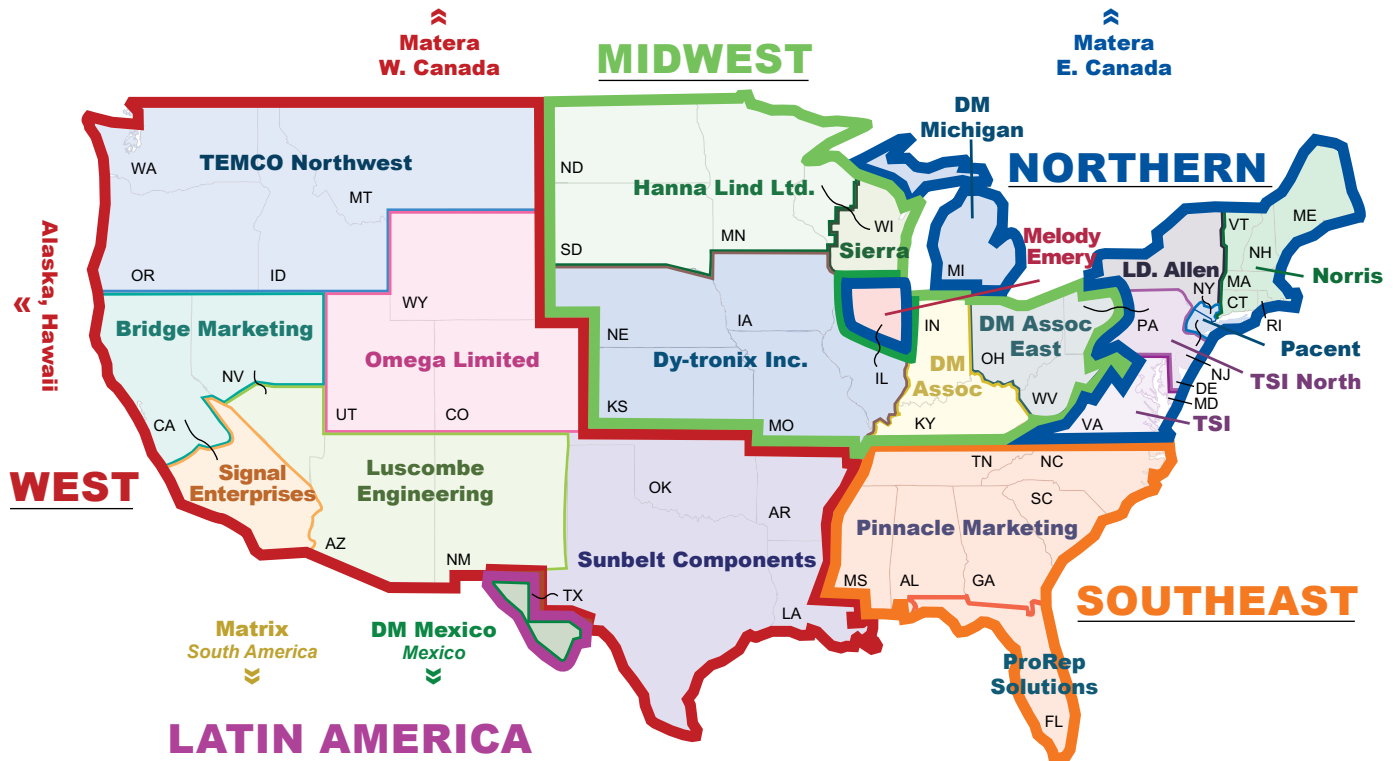

Americas



Europe
Middle East
Africa



Asia-Pacific
Oceania

About Carling

Founded in 1920, Carling Technologies is a leading manufacturer of electrical and electronic switches and assemblies, circuit breakers, electronic controls, power distribution units, and multiplexed power distribution systems. With four ISO registered manufacturing facilities and technical sales offices worldwide, Carling Technologies Sales, Service and Engineering teams do much more than manufacture electrical components, they engineer powerful solutions! To learn more about Carling please visit www.carlingtech.com/company-profile.

To view all of Carling's environmental, quality, health & safety certifications please visit www.carlingtech.com/environmental-certifications

Worldwide Headquarters

Carling Technologies, Inc.
60 Johnson Avenue, Plainville, CT 06062
Phone: 860.793.9281 **Fax:** 860.793.9231
Email: sales@carlingtech.com

Northern Region Sales Office: nrsm@carlingtech.com
Southeast Region Sales Office: sersm@carlingtech.com
Midwest Region Sales Office: mrrsm@carlingtech.com
West Region Sales Office: wrsm@carlingtech.com
Latin America Sales Office: larsm@carlingtech.com

Asia-Pacific Headquarters

Carling Technologies, Asia-Pacific Ltd.,
Kowloon, Hong Kong
Phone: Int + 852-2737-2277 **Fax:** Int + 852-2736-9332
Email: sales@carlingtech.com.hk

Shenzhen, China: shenzhen@carlingtech.com
Shanghai, China: shanghai@carlingtech.com
Pune, India: india@carlingtech.com
Kaohsiung, Taiwan: taiwan@carlingtech.com
Yokohama, Japan: japan@carlingtech.com

Europe | Middle East | Africa Headquarters

Carling Technologies LTD
4 Airport Business Park, Exeter Airport,
Clyst Honiton, Exeter, Devon, EX5 2UL, UK
Phone: Int + 44 1392.364422 **Fax:** Int + 44 1392.364477
Email: ltd.sales@carlingtech.com

Germany: gmbh@carlingtech.com
France: sas@carlingtech.com



Carling Technologies™

Innovative Designs. Powerful Solutions.