

# IRLS3036PbF IRLSL3036PbF

HEXFET® Power MOSFET

## Applications

- DC Motor Drive
- High Efficiency Synchronous Rectification in SMPS
- Uninterruptible Power Supply
- High Speed Power Switching
- Hard Switched and High Frequency Circuits

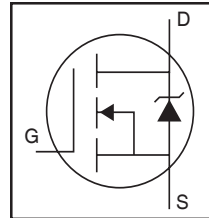

|                         |      |               |
|-------------------------|------|---------------|
| $V_{DSS}$               |      | <b>60V</b>    |
| $R_{DS(on)}$            | typ. | <b>1.9mΩ</b>  |
|                         | max. | <b>2.4mΩ</b>  |
| $I_D$ (Silicon Limited) |      | <b>270A</b> ① |
| $I_D$ (Package Limited) |      | <b>195A</b>   |

## Benefits

- Optimized for Logic Level Drive
- Very Low  $R_{DS(ON)}$  at 4.5V  $V_{GS}$
- Superior  $R^*Q$  at 4.5V  $V_{GS}$
- Improved Gate, Avalanche and Dynamic  $dV/dt$  Ruggedness
- Fully Characterized Capacitance and Avalanche SOA
- Enhanced body diode  $dV/dt$  and  $dI/dt$  Capability
- Lead-Free

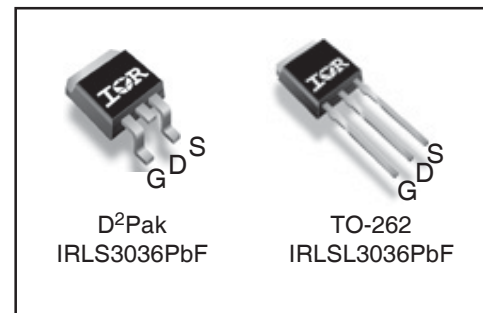

|          |          |          |
|----------|----------|----------|
| <b>G</b> | <b>D</b> | <b>S</b> |
| Gate     | Drain    | Source   |

## Absolute Maximum Ratings

| Symbol                            | Parameter  | Max.         | Units |
|-----------------------------------|--|--------------|-------|
| $I_D$ @ $T_C = 25^\circ\text{C}$  | Continuous Drain Current, $V_{GS}$ @ 10V (Silicon Limited) | 270 ①        | A     |
| $I_D$ @ $T_C = 100^\circ\text{C}$ | Continuous Drain Current, $V_{GS}$ @ 10V (Silicon Limited) | 190 ①        |       |
| $I_D$ @ $T_C = 25^\circ\text{C}$  | Continuous Drain Current, $V_{GS}$ @ 10V (Package Limited) | 195          |       |
| $I_{DM}$                          | Pulsed Drain Current ②                                     | 1100         |       |
| $P_D$ @ $T_C = 25^\circ\text{C}$  | Maximum Power Dissipation                                  | 380          | W     |
|                                   | Linear Derating Factor                                     | 2.5          | W/°C  |
| $V_{GS}$                          | Gate-to-Source Voltage                                     | ±16          | V     |
| $dv/dt$                           | Peak Diode Recovery ④                                      | 8.0          | V/ns  |
| $T_J$                             | Operating Junction and                                     | -55 to + 175 | °C    |
| $T_{STG}$                         | Storage Temperature Range                                  |              |       |
|                                   | Soldering Temperature, for 10 seconds<br>(1.6mm from case) | 300          |       |

## Avalanche Characteristics

|                              |                                 |                           |    |
|------------------------------|---------------------------------|---------------------------|----|
| $E_{AS}$ (Thermally limited) | Single Pulse Avalanche Energy ③ | 290                       | mJ |
| $I_{AR}$                     | Avalanche Current ②             | See Fig. 14, 15, 22a, 22b | A  |
| $E_{AR}$                     | Repetitive Avalanche Energy ⑩   |                           | mJ |

## Thermal Resistance

| Symbol          | Parameter                                       | Typ. | Max. | Units |
|-----------------|---|------|------|-------|
| $R_{\theta JC}$ | Junction-to-Case ⑨ ⑪                            | —    | 0.40 | °C/W  |
| $R_{\theta JA}$ | Junction-to-Ambient (PCB Mount, steady state) ⑩ | —    | 40   |       |

Static @  $T_J = 25^\circ\text{C}$  (unless otherwise specified)

| Symbol                          | Parameter                            | Min. | Typ.  | Max. | Units               | Conditions   |
|---------------------------------|--------------------------------------|------|-------|------|---------------------|--|
| $V_{(BR)DSS}$                   | Drain-to-Source Breakdown Voltage    | 60   | —     | —    | V                   | $V_{GS} = 0V, I_D = 250\mu A$                        |
| $\Delta V_{(BR)DSS}/\Delta T_J$ | Breakdown Voltage Temp. Coefficient  | —    | 0.061 | —    | V/ $^\circ\text{C}$ | Reference to $25^\circ\text{C}, I_D = 5mA$ ②         |
| $R_{DS(on)}$                    | Static Drain-to-Source On-Resistance | —    | 1.9   | 2.4  | m $\Omega$          | $V_{GS} = 10V, I_D = 165A$ ③                         |
|                                 |                                      | —    | 2.2   | 2.8  |                     | $V_{GS} = 4.5V, I_D = 140A$ ③                        |
| $V_{GS(th)}$                    | Gate Threshold Voltage               | 1.0  | —     | 2.5  | V                   | $V_{DS} = V_{GS}, I_D = 250\mu A$                    |
| $I_{DSS}$                       | Drain-to-Source Leakage Current      | —    | —     | 20   | $\mu A$             | $V_{DS} = 60V, V_{GS} = 0V$                          |
|                                 |                                      | —    | —     | 250  |                     | $V_{DS} = 60V, V_{GS} = 0V, T_J = 125^\circ\text{C}$ |
| $I_{GSS}$                       | Gate-to-Source Forward Leakage       | —    | —     | 100  | nA                  | $V_{GS} = 16V$                                       |
|                                 | Gate-to-Source Reverse Leakage       | —    | —     | -100 |                     | $V_{GS} = -16V$                                      |
| $R_{G(int)}$                    | Internal Gate Resistance             | —    | 2.0   | —    | $\Omega$            |  |

Dynamic @  $T_J = 25^\circ\text{C}$  (unless otherwise specified)

| Symbol               | Parameter                                       | Min. | Typ.  | Max. | Units | Conditions                                   |
|----------------------|---|------|-------|------|-------|--|
| gfs                  | Forward Transconductance                        | 340  | —     | —    | S     | $V_{DS} = 10V, I_D = 165A$                   |
| $Q_g$                | Total Gate Charge                               | —    | 91    | 140  | nC    | $I_D = 165A$                                 |
| $Q_{gs}$             | Gate-to-Source Charge                           | —    | 31    | —    |       | $V_{DS} = 30V$                               |
| $Q_{gd}$             | Gate-to-Drain ("Miller") Charge                 | —    | 51    | —    |       | $V_{GS} = 4.5V$ ⑤                            |
| $Q_{sync}$           | Total Gate Charge Sync. ( $Q_g - Q_{gd}$ )      | —    | 40    | —    |       | $I_D = 165A, V_{DS} = 0V, V_{GS} = 4.5V$     |
| $t_{d(on)}$          | Turn-On Delay Time                              | —    | 66    | —    | ns    | $V_{DD} = 39V$                               |
| $t_r$                | Rise Time                                       | —    | 220   | —    |       | $I_D = 165A$                                 |
| $t_{d(off)}$         | Turn-Off Delay Time                             | —    | 110   | —    |       | $R_G = 2.1\Omega$                            |
| $t_f$                | Fall Time                                       | —    | 110   | —    |       | $V_{GS} = 4.5V$ ⑤                            |
| $C_{iss}$            | Input Capacitance                               | —    | 11210 | —    | pF    | $V_{GS} = 0V$                                |
| $C_{oss}$            | Output Capacitance                              | —    | 1020  | —    |       | $V_{DS} = 50V$                               |
| $C_{riss}$           | Reverse Transfer Capacitance                    | —    | 500   | —    |       | $f = 1.0MHz$                                 |
| $C_{oss\ eff. (ER)}$ | Effective Output Capacitance (Energy Related) ⑦ | —    | 1430  | —    |       | $V_{GS} = 0V, V_{DS} = 0V \text{ to } 48V$ ⑦ |
| $C_{oss\ eff. (TR)}$ | Effective Output Capacitance (Time Related) ⑥   | —    | 1880  | —    |       | $V_{GS} = 0V, V_{DS} = 0V \text{ to } 48V$ ⑥ |

## Diode Characteristics

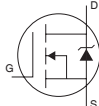
| Symbol    | Parameter                                 | Min.   | Typ. | Max. | Units | Conditions   |
|-----------|---|--|------|------|-------|--|
| $I_S$     | Continuous Source Current<br>(Body Diode) | —  | —    | 270  | A     | MOSFET symbol showing the integral reverse p-n junction diode.  |
| $I_{SM}$  | Pulsed Source Current<br>(Body Diode) ③   | —  | —    | 1100 |       |  |
| $V_{SD}$  | Diode Forward Voltage                     | —  | —    | 1.3  | V     | $T_J = 25^\circ\text{C}, I_S = 165A, V_{GS} = 0V$ ⑤  |
| $t_{rr}$  | Reverse Recovery Time                     | —  | 62   | —    | ns    | $T_J = 25^\circ\text{C}$ $V_R = 51V,$  |
|           |   | —  | 66   | —    |       | $T_J = 125^\circ\text{C}$ $I_F = 165A$   |
| $Q_{rr}$  | Reverse Recovery Charge                   | —  | 310  | —    | nC    | $T_J = 25^\circ\text{C}$ $di/dt = 100A/\mu s$ ⑤  |
|           |   | —  | 360  | —    |       | $T_J = 125^\circ\text{C}$  |
| $I_{RRM}$ | Reverse Recovery Current                  | —  | 4.4  | —    | A     | $T_J = 25^\circ\text{C}$   |
| $t_{on}$  | Forward Turn-On Time                      | Intrinsic turn-on time is negligible (turn-on is dominated by LS+LD) |      |      |       |  |

## Notes:

- ① Calculated continuous current based on maximum allowable junction temperature Bond wire current limit is 195A. Note that current limitation arising from heating of the device leads may occur with some lead mounting arrangements.
- ② Repetitive rating; pulse width limited by max. junction temperature.
- ③ Limited by  $T_{Jmax}$ , starting  $T_J = 25^\circ\text{C}$ ,  $L = 0.021mH$   
 $R_G = 25\Omega, I_{AS} = 165A, V_{GS} = 10V$ . Part not recommended for use above this value.
- ④  $I_{SD} \leq 165A, di/dt \leq 430A/\mu s, V_{DD} \leq V_{(BR)DSS}, T_J \leq 175^\circ\text{C}$ .
- ⑤ Pulse width  $\leq 400\mu s$ ; duty cycle  $\leq 2\%$ .
- ⑥  $C_{oss\ eff. (TR)}$  is a fixed capacitance that gives the same charging time as  $C_{oss}$  while  $V_{DS}$  is rising from 0 to 80%  $V_{DSS}$ .
- ⑦  $C_{oss\ eff. (ER)}$  is a fixed capacitance that gives the same energy as  $C_{oss}$  while  $V_{DS}$  is rising from 0 to 80%  $V_{DSS}$ .
- ⑧ When mounted on 1" square PCB (FR-4 or G-10 Material). For recommended footprint and soldering techniques refer to application note #AN-994.
- ⑨  $R_{\theta j}$  is measured at  $T_J$  approximately  $90^\circ\text{C}$ .
- ⑩ Limited by  $T_{Jmax}$ , see Fig. 14, 15, 22a, 22b for typical repetitive avalanche performance.
- ⑪  $R_{\theta JC}$  value shown is at time zero.

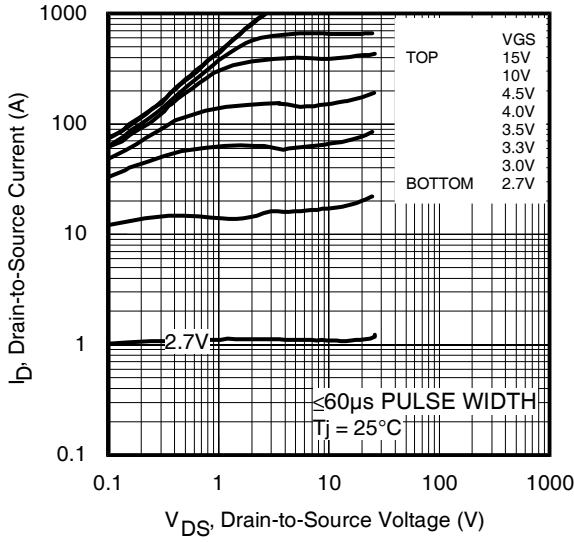

Fig 1. Typical Output Characteristics

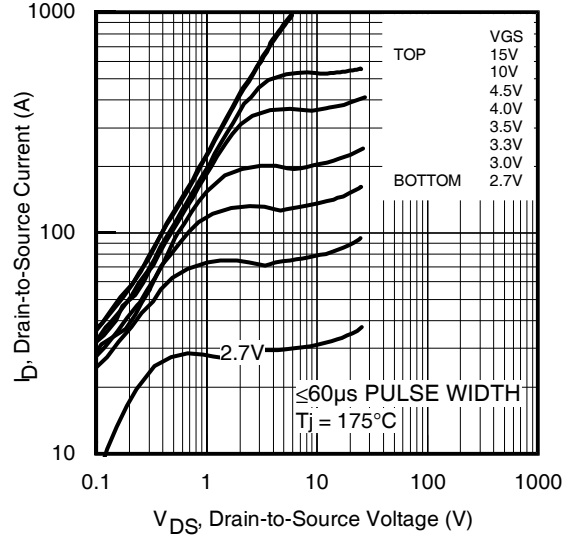

Fig 2. Typical Output Characteristics

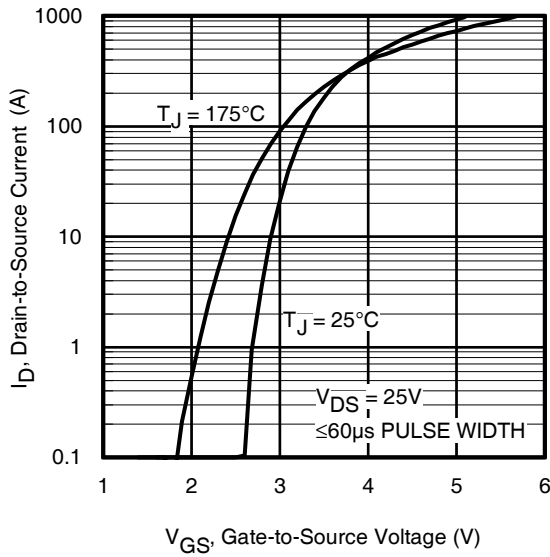

Fig 3. Typical Transfer Characteristics

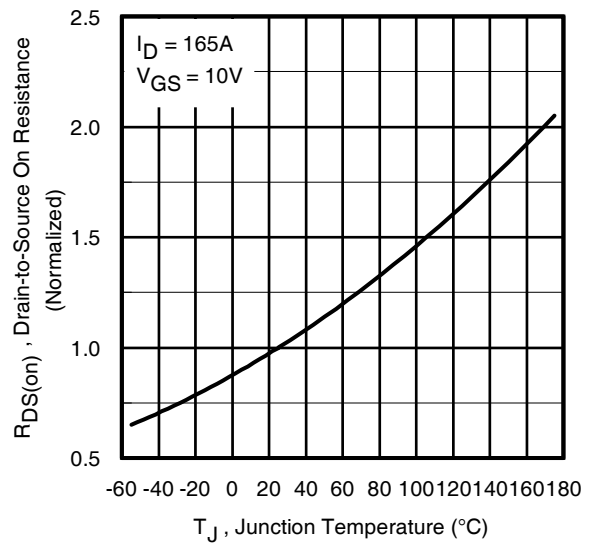

Fig 4. Normalized On-Resistance vs. Temperature

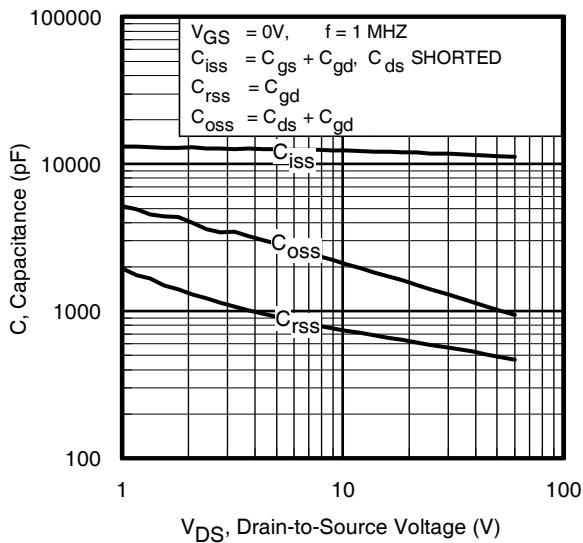

Fig 5. Typical Capacitance vs. Drain-to-Source Voltage

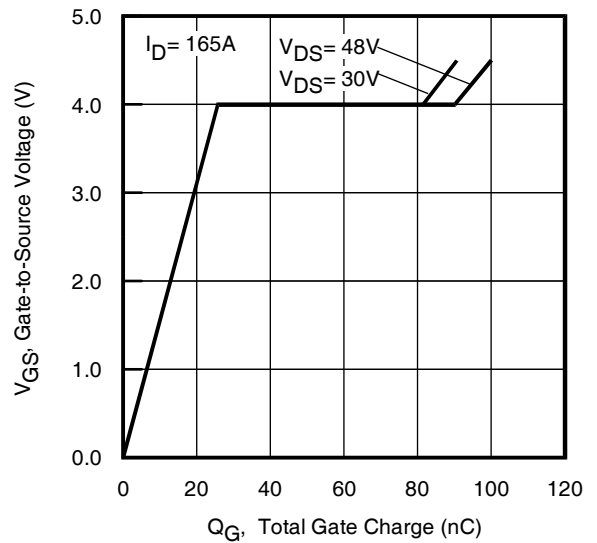

Fig 6. Typical Gate Charge vs. Gate-to-Source Voltage

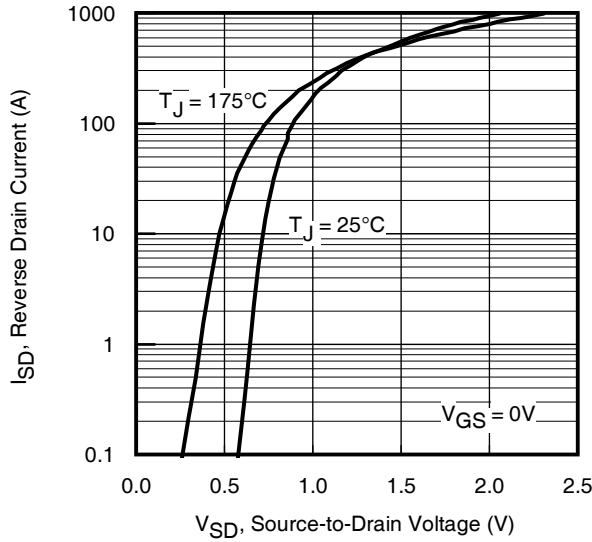

Fig 7. Typical Source-Drain Diode Forward Voltage

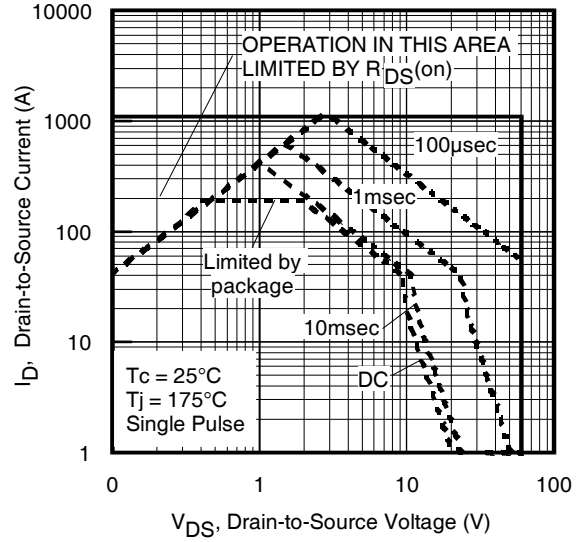

Fig 8. Maximum Safe Operating Area

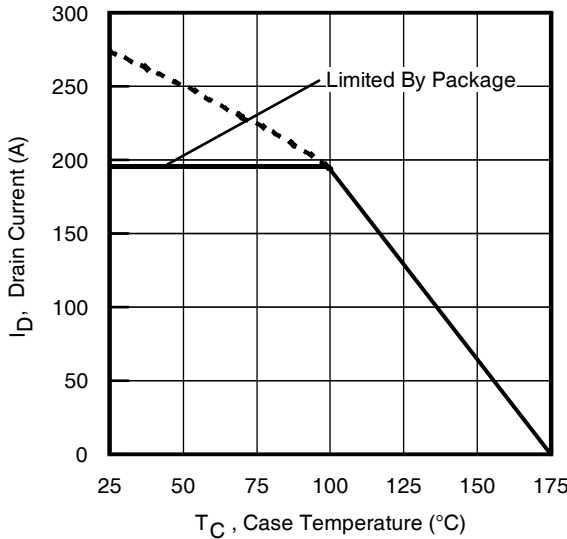

Fig 9. Maximum Drain Current vs. Case Temperature

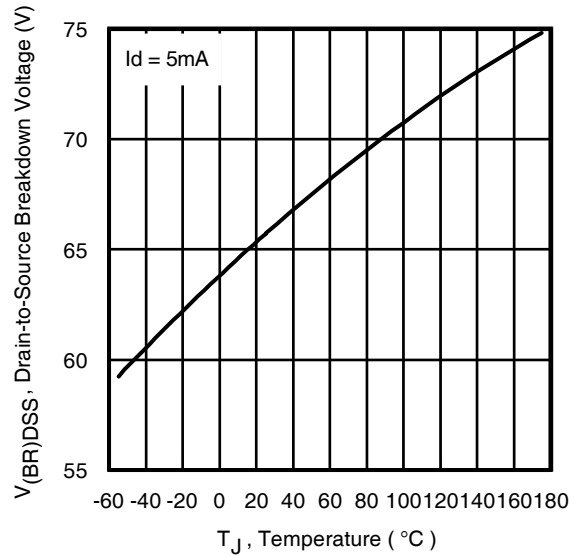

Fig 10. Drain-to-Source Breakdown Voltage

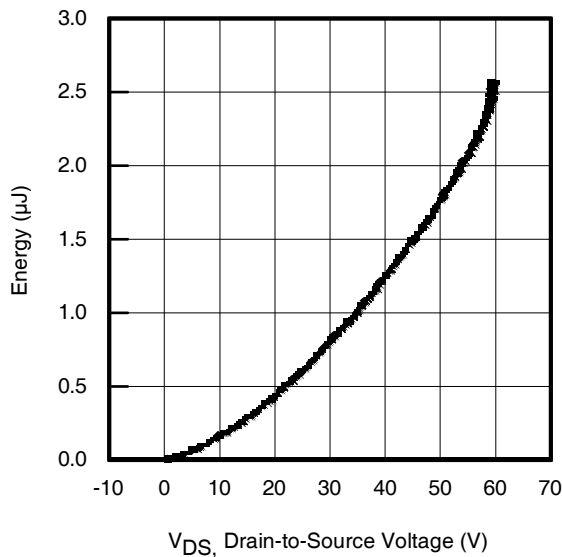

Fig 11. Typical  $C_{OSS}$  Stored Energy

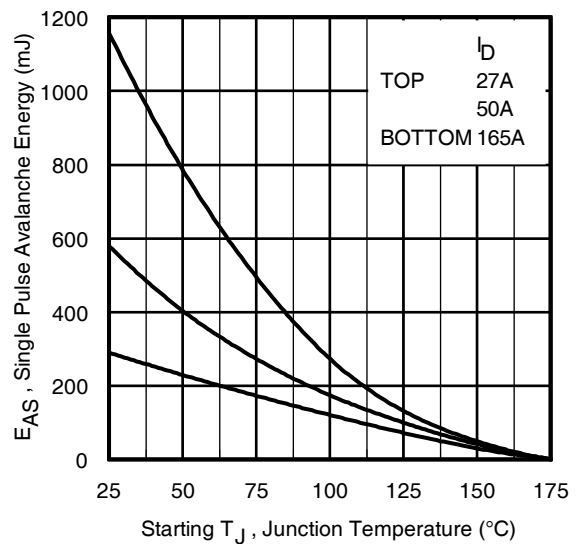

Fig 12. Maximum Avalanche Energy vs. Drain Current

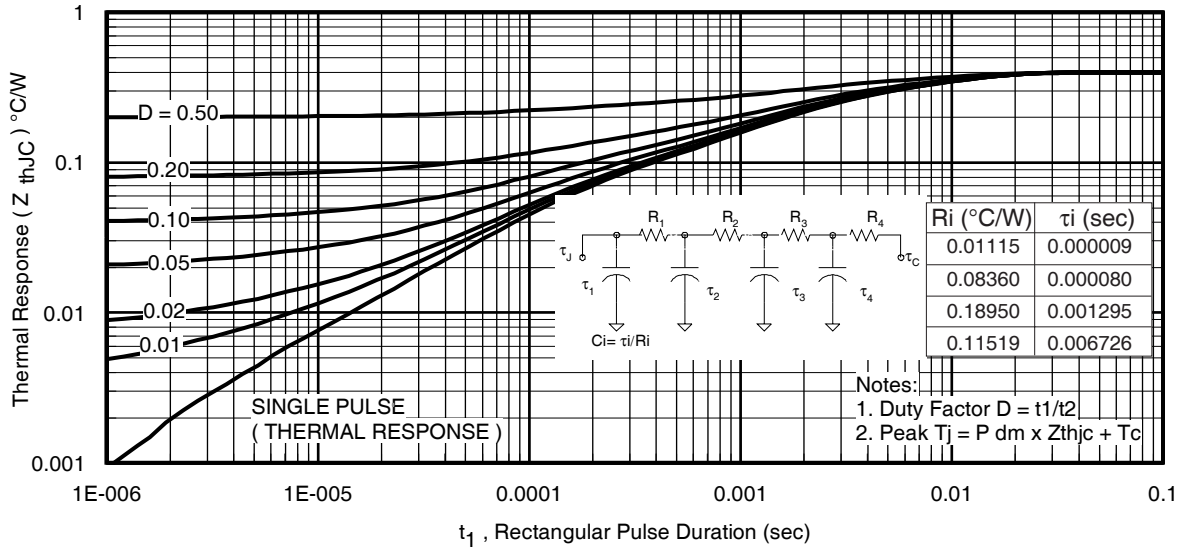

Fig 13. Maximum Effective Transient Thermal Impedance, Junction-to-Case

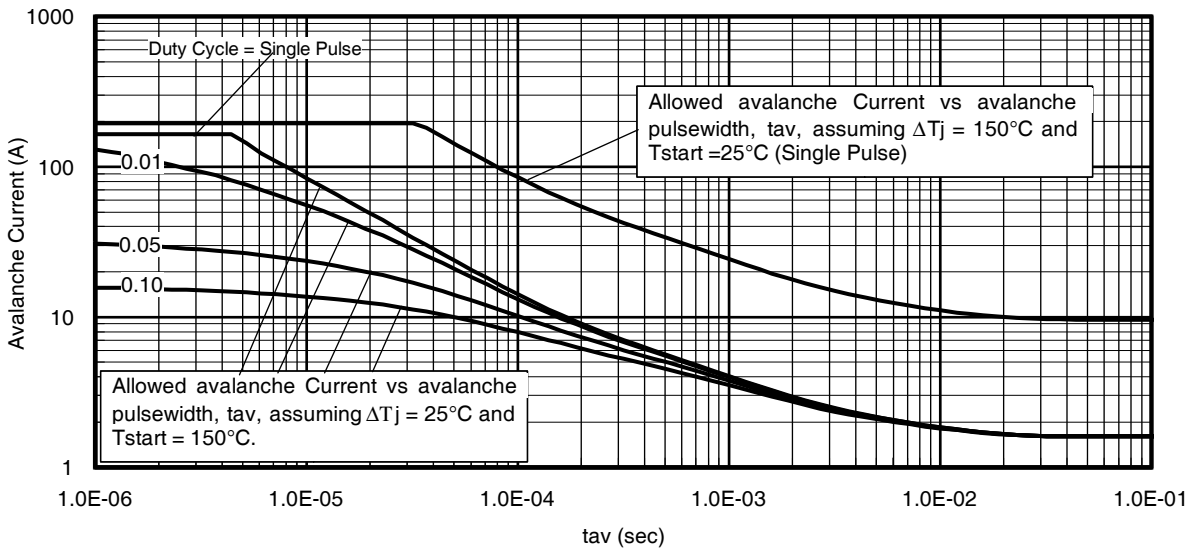

Fig 14. Typical Avalanche Current vs. Pulsewidth

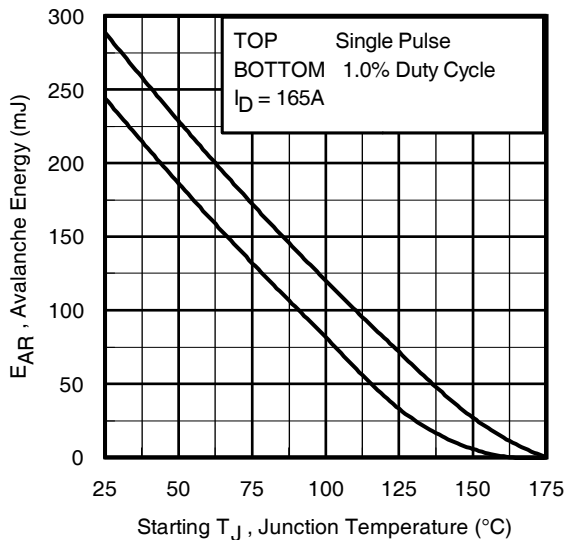

Fig 15. Maximum Avalanche Energy vs. Temperature

**Notes on Repetitive Avalanche Curves, Figures 14, 15:**  
(For further info, see AN-1005 at [www.irf.com](http://www.irf.com))

1. Avalanche failures assumption:  
Purely a thermal phenomenon and failure occurs at a temperature far in excess of  $T_{jmax}$ . This is validated for every part type.
2. Safe operation in Avalanche is allowed as long as  $T_{jmax}$  is not exceeded.
3. Equation below based on circuit and waveforms shown in Figures 16a, 16b.
4.  $P_{D(ave)}$  = Average power dissipation per single avalanche pulse.
5. BV = Rated breakdown voltage (1.3 factor accounts for voltage increase during avalanche).
6.  $I_{av}$  = Allowable avalanche current.
7.  $\Delta T$  = Allowable rise in junction temperature, not to exceed  $T_{jmax}$  (assumed as 25°C in Figure 14, 15).  
 $t_{av}$  = Average time in avalanche.  
 $D$  = Duty cycle in avalanche =  $t_{av} \cdot f$   
 $Z_{thJC}(D, t_{av})$  = Transient thermal resistance, see Figures 13)

$$P_{D(ave)} = 1/2 (1.3 \cdot BV \cdot I_{av}) = \Delta T / Z_{thJC}$$

$$I_{av} = 2\Delta T / [1.3 \cdot BV \cdot Z_{th}]$$

$$E_{AS(AR)} = P_{D(ave)} \cdot t_{av}$$

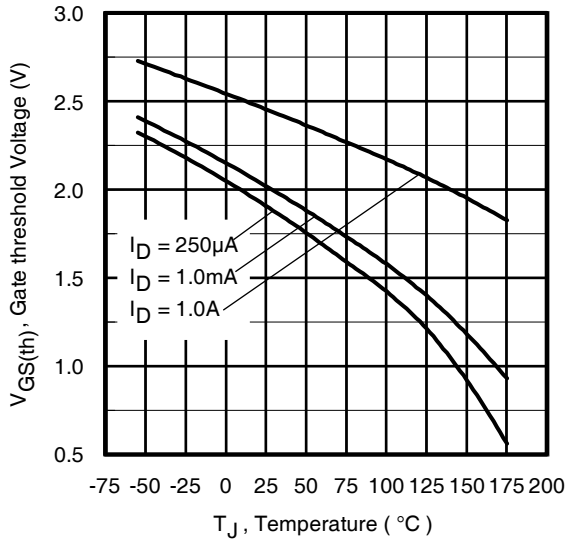

Fig 16. Threshold Voltage vs. Temperature

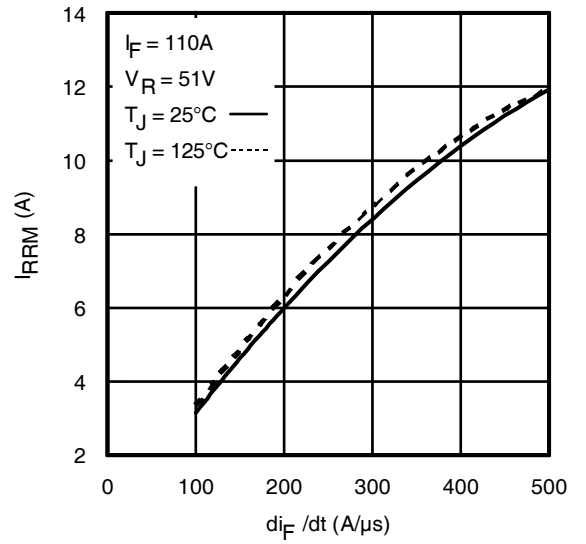

Fig. 17 - Typical Recovery Current vs.  $di_F/dt$

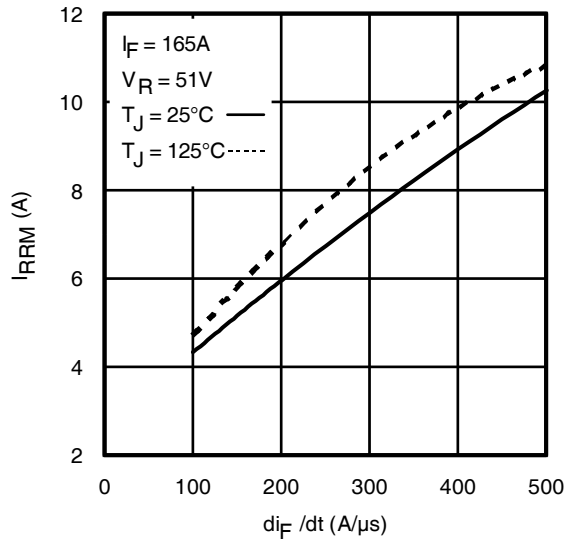

Fig. 18 - Typical Recovery Current vs.  $di_F/dt$

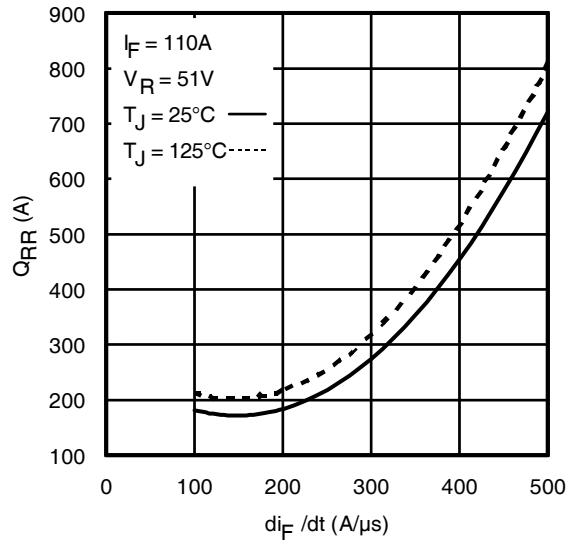

Fig. 19 - Typical Stored Charge vs.  $di_F/dt$

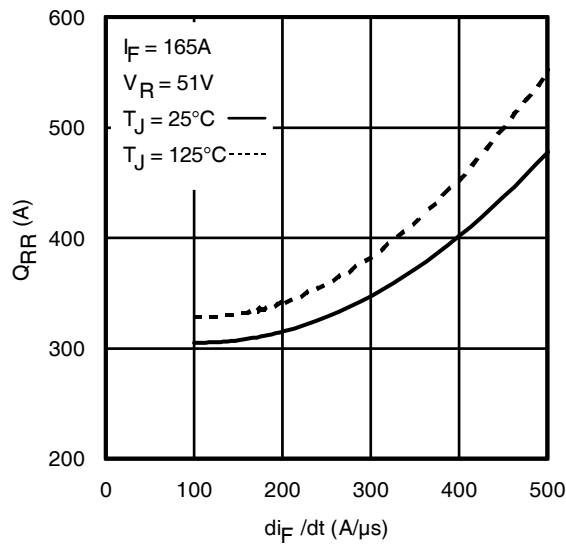
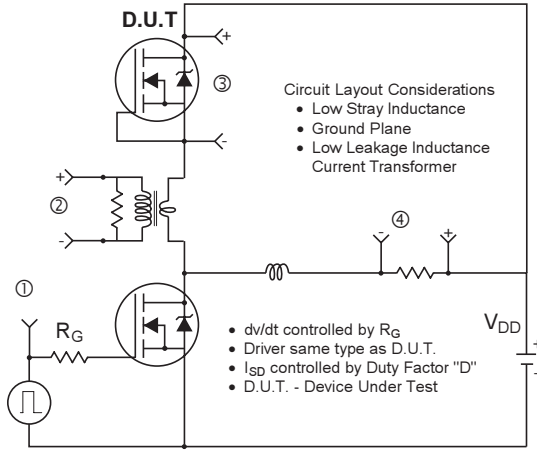
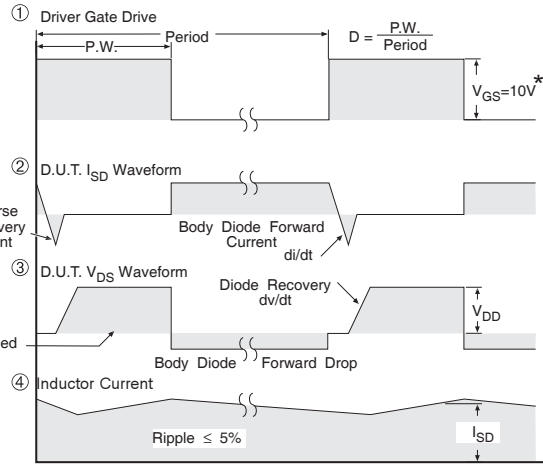

Fig. 20 - Typical Stored Charge vs.  $di_F/dt$



**Fig 21. Peak Diode Recovery dv/dt Test Circuit for N-Channel HEXFET® Power MOSFETs**



\*  $V_{GS} = 5V$  for Logic Level Devices

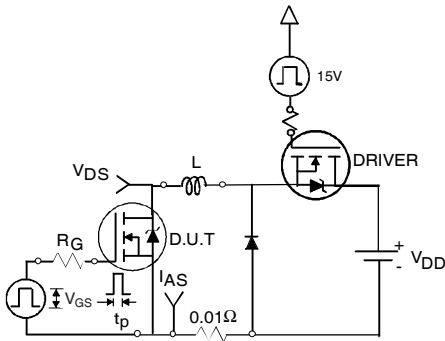

**Fig 22a. Unclamped Inductive Test Circuit**



**Fig 22b. Unclamped Inductive Waveforms**

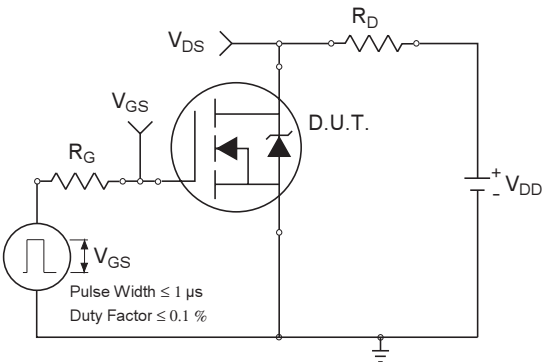

**Fig 23a. Switching Time Test Circuit**

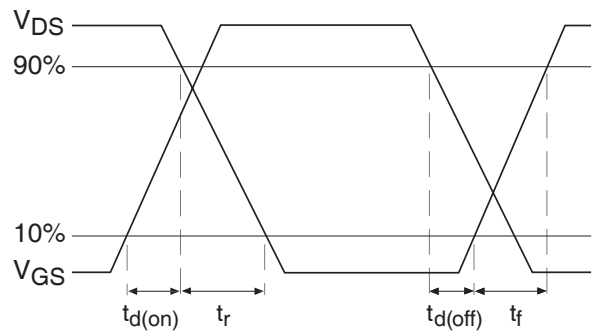

**Fig 23b. Switching Time Waveforms**

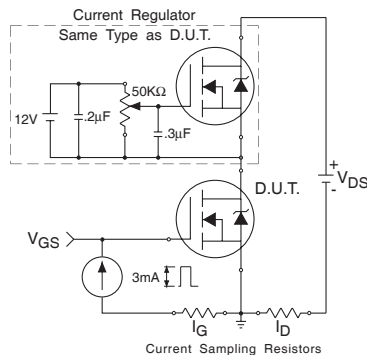

**Fig 24a. Gate Charge Test Circuit**

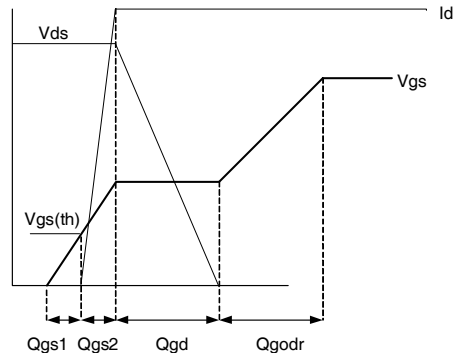
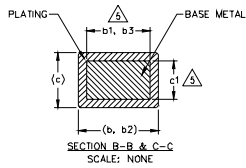
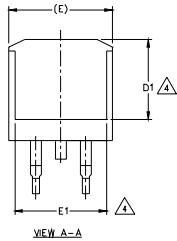
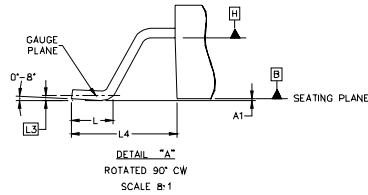
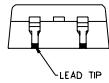
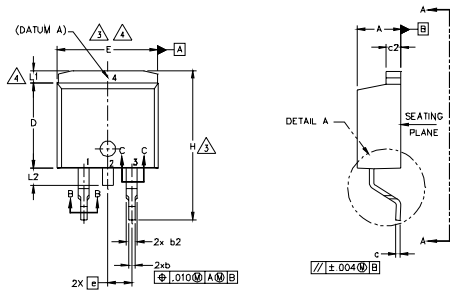

**Fig 24b. Gate Charge Waveform**

# IRLS/SL3036PbF

## D<sup>2</sup>Pak (TO-263AB) Package Outline

Dimensions are shown in millimeters (inches)



### LEAD ASSIGNMENTS

#### DIODES

- 1.- ANODE (TWO DIE) / OPEN (ONE DIE)
- 2.- CATHODE
- 3.- ANODE

#### HEXFET

- 1.- GATE
- 2.- DRAIN
- 3.- SOURCE

#### IGBTs, CoPACK

- 1.- GATE
- 2.- COLLECTOR
- 3.- EMITTER

| SYMBOL | DIMENSIONS  |       |          |      | NOTES |
|--------|-------------|-------|----------|------|-------|
|        | MILLIMETERS |       | INCHES   |      |       |
|        | MIN.        | MAX.  | MIN.     | MAX. |       |
| A      | 4.06        | 4.83  | .160     | .190 | 5     |
| A1     | 0.00        | 0.254 | .000     | .010 |       |
| b      | 0.51        | 0.99  | .020     | .039 |       |
| b1     | 0.51        | 0.89  | .020     | .035 |       |
| b2     | 1.14        | 1.78  | .045     | .070 |       |
| b3     | 1.14        | 1.73  | .045     | .068 |       |
| c      | 0.38        | 0.74  | .015     | .029 |       |
| c1     | 0.38        | 0.58  | .015     | .023 |       |
| c2     | 1.14        | 1.65  | .045     | .065 |       |
| D      | 8.38        | 9.65  | .330     | .380 |       |
| D1     | 6.86        | -     | .270     | -    |       |
| E      | 9.65        | 10.67 | .380     | .420 |       |
| E1     | 6.22        | -     | .245     | -    |       |
| e      | 2.54 BSC    |       | .100 BSC |      |       |
| H      | 14.61       | 15.88 | .575     | .625 | 4     |
| L      | 1.78        | 2.79  | .070     | .110 |       |
| L1     | -           | 1.65  | -        | .066 |       |
| L2     | -           | 1.78  | -        | .070 |       |
| L3     | 0.25 BSC    |       | .010 BSC |      |       |
| L4     | 4.78        | 5.28  | .188     | .208 |       |

### NOTES:

1. DIMENSIONING AND TOLERANCING PER ASME Y14.5M-1994
2. DIMENSIONS ARE SHOWN IN MILLIMETERS [INCHES].
3. DIMENSION D & E DO NOT INCLUDE MOLD FLASH. MOLD FLASH SHALL NOT EXCEED 0.127 [0.005"] PER SIDE. THESE DIMENSIONS ARE MEASURED AT THE OUTMOST EXTREMES OF THE PLASTIC BODY AT DATUM H.
4. THERMAL PAD CONTOUR OPTIONAL WITHIN DIMENSION E, L1, D1 & E1.
5. DIMENSION b1 AND c1 APPLY TO BASE METAL ONLY.
6. DATUM A & B TO BE DETERMINED AT DATUM PLANE H.
7. CONTROLLING DIMENSION: INCH.
8. OUTLINE CONFORMS TO JEDEC OUTLINE TO-263AB.

## D<sup>2</sup>Pak (TO-263AB) Part Marking Information

EXAMPLE: THIS IS AN IRF530S WITH  
LOT CODE 8024  
ASSEMBLED ON WW 02, 2000  
IN THE ASSEMBLY LINE "L"

Note: "P" in assembly line position  
indicates "Lead - Free"

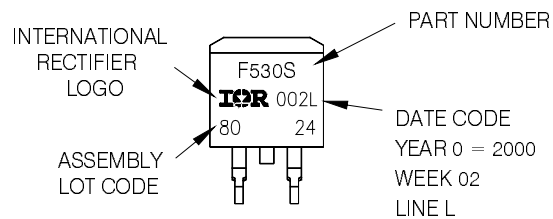

OR

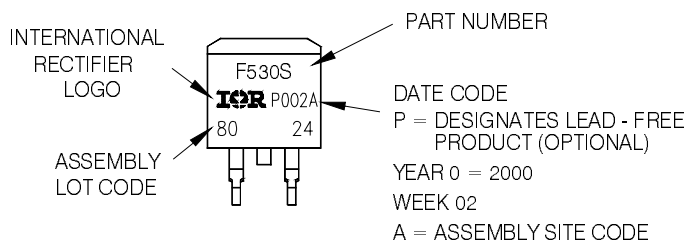

Note: For the most current drawing please refer to IR website at <http://www.irf.com/package/>



## TO-262 Package Outline

Dimensions are shown in millimeters (inches)

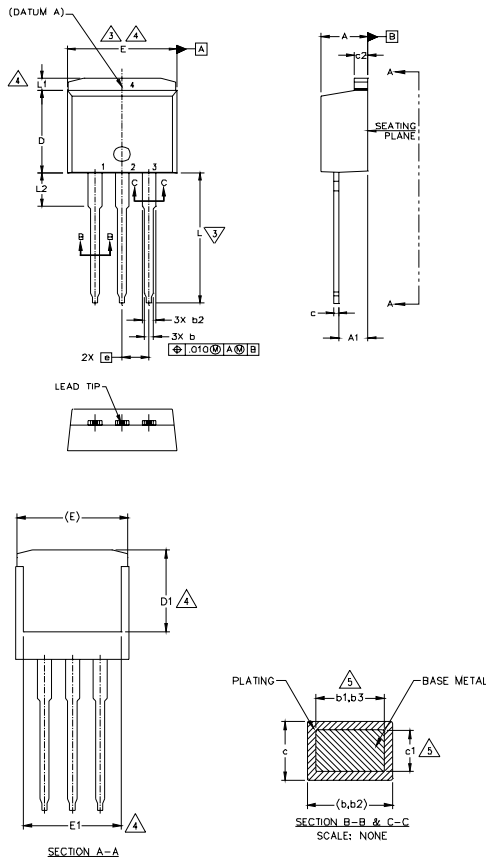

| SYMBOL | DIMENSIONS  |       |          |      | NOTES |
|--------|-------------|-------|----------|------|-------|
|        | MILLIMETERS |       | INCHES   |      |       |
|        | MIN.        | MAX.  | MIN.     | MAX. |       |
| A      | 4.06        | 4.83  | .160     | .190 |       |
| A1     | 2.03        | 3.02  | .080     | .119 |       |
| b      | 0.51        | 0.99  | .020     | .039 |       |
| b1     | 0.51        | 0.89  | .020     | .035 | 5     |
| b2     | 1.14        | 1.78  | .045     | .070 |       |
| b3     | 1.14        | 1.73  | .045     | .068 | 5     |
| c      | 0.38        | 0.74  | .015     | .029 |       |
| c1     | 0.38        | 0.58  | .015     | .023 | 5     |
| c2     | 1.14        | 1.65  | .045     | .065 |       |
| D      | 8.38        | 9.65  | .330     | .380 | 3     |
| D1     | 6.86        | —     | .270     | —    | 4     |
| E      | 9.65        | 10.67 | .380     | .420 | 3,4   |
| E1     | 6.22        | —     | .245     | —    | 4     |
| e      | 2.54 BSC    |       | .100 BSC |      |       |
| L      | 13.46       | 14.10 | .530     | .555 |       |
| L1     | —           | 1.65  | —        | .065 | 4     |
| L2     | 3.56        | 3.71  | .140     | .146 |       |

- NOTES:
1. DIMENSIONING AND TOLERANCING PER ASME Y14.5M-1994
  2. DIMENSIONS ARE SHOWN IN MILLIMETERS (INCHES)
  3. DIMENSION D & E DO NOT INCLUDE MOLD FLASH. MOLD FLASH SHALL NOT EXCEED 0.127 [0.005] PER SIDE. THESE DIMENSIONS ARE MEASURED AT THE OUTMOST EXTREMES OF THE PLASTIC BODY.
  4. TERMINAL PAD CONTOUR OPTIONAL WITHIN DIMENSION L, L1, D1 & E1.
  5. DIMENSION b1 AND c1 APPLY TO BASE METAL ONLY.
  6. CONTROLLING DIMENSION: INCH.
  7. - OUTLINE CONFORMS TO JEDEC TO-262 EXCEPT A1(max.), b1(min.) AND D1(min.) WHERE DIMENSIONS DERIVED THE ACTUAL PACKAGE OUTLINE.

**LEAD ASSIGNMENTS**

- IGBTs, GpPACs**
- 1 - GATE
  - 2 - COLLECTOR
  - 3 - EMITTER
  - 4 - COLLECTOR

**DIODES**

- |            |                                   |
|------------|-----------------------------------|
| 1 - GATE   | 1 - ANODE (NO DI) / OPEN (ONE DI) |
| 2 - DRAIN  | 2, 4 - CATHODE                    |
| 3 - SOURCE | 3 - ANODE                         |
| 4 - DRAIN  |                                   |

## TO-262 Part Marking Information

EXAMPLE: THIS IS AN IRL3103L  
LOT CODE 1789  
ASSEMBLED ON WW 19, 1997  
IN THE ASSEMBLY LINE "C"

Note: "p" in assembly line position indicates "Lead - Free"

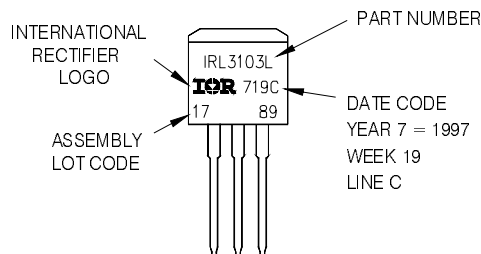

OR

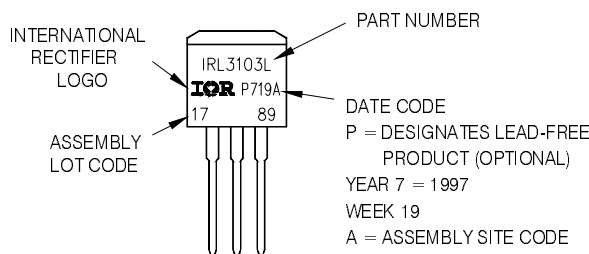

Note: For the most current drawing please refer to IR website at <http://www.irf.com/package/>

# IRLS/SL3036PbF

## D<sup>2</sup>Pak (TO-263AB) Tape & Reel Information

Dimensions are shown in millimeters (inches)

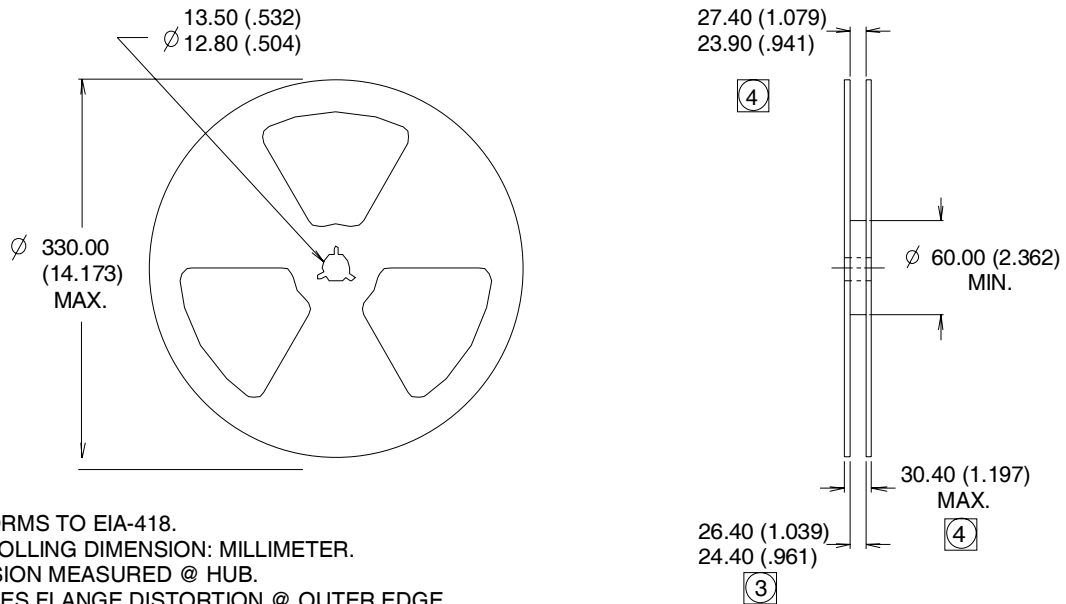
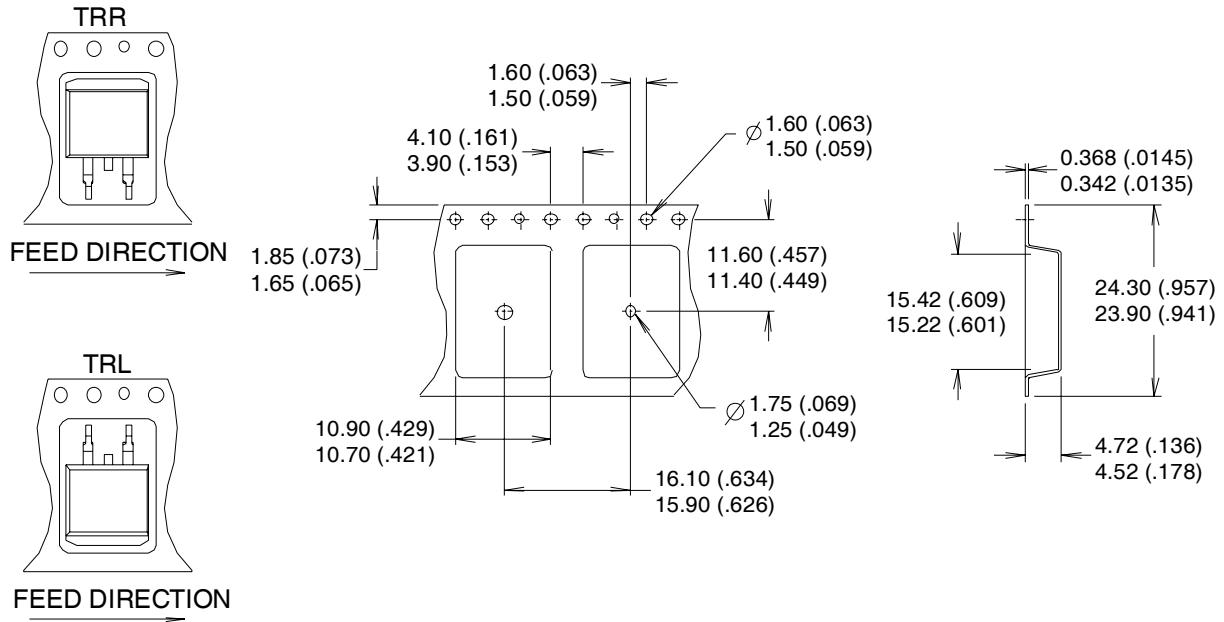

Note: For the most current drawing please refer to IR website at <http://www.irf.com/package/>

Data and specifications subject to change without notice.  
This product has been designed and qualified for the Industrial market.  
Qualification Standards can be found on IR's Web site.