

ORDERING INFORMATION

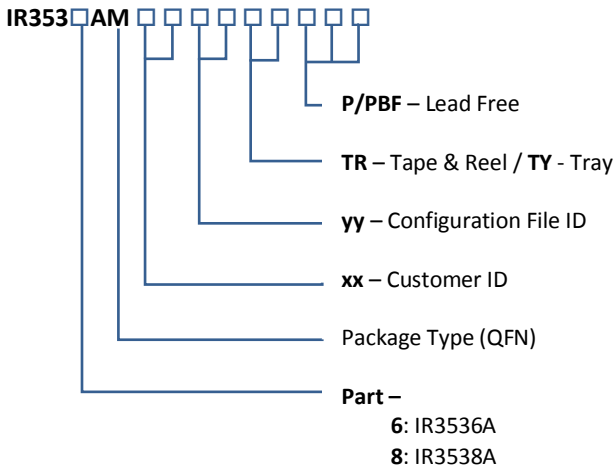

Package	Packing Qty	Part Number	Programming
QFN	TR=3000	IR3536AMTRPBF	Default
	TY=2600	IR3536AMTYPBF	
QFN	TR=3000	IR3538AMTRPBF	Default
	TY=2600	IR3538AMTYPBF	
QFN	TR=3000	IR3536AMxxyyTRP¹	Customer Configuration
QFN	TR=3000	IR3538AMxxyyTRP¹	Customer Configuration

Notes:

1. Customer Specific Configuration File, where xx = Customer ID and yy = Configuration File (Codes assigned by IR Marketing).

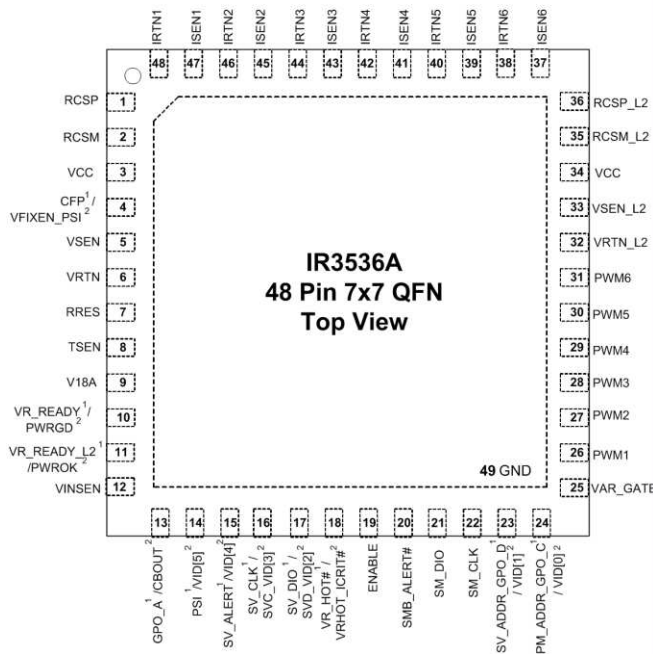

Figure 3: IR3536A Package Top View, Enlarged

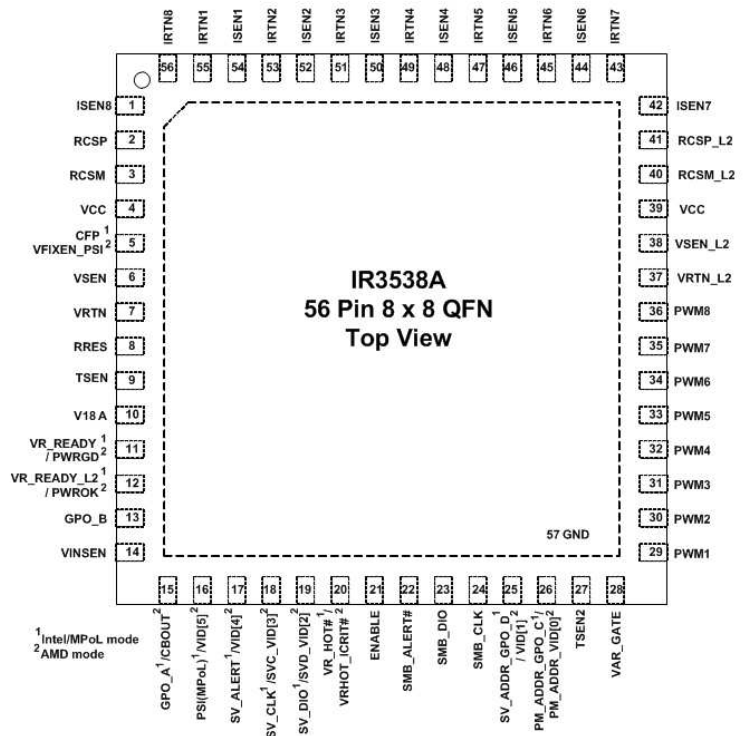

Figure 4: IR3538A Package Top View, Enlarged

TYPICAL APPLICATIONS BLOCK DIAGRAMS

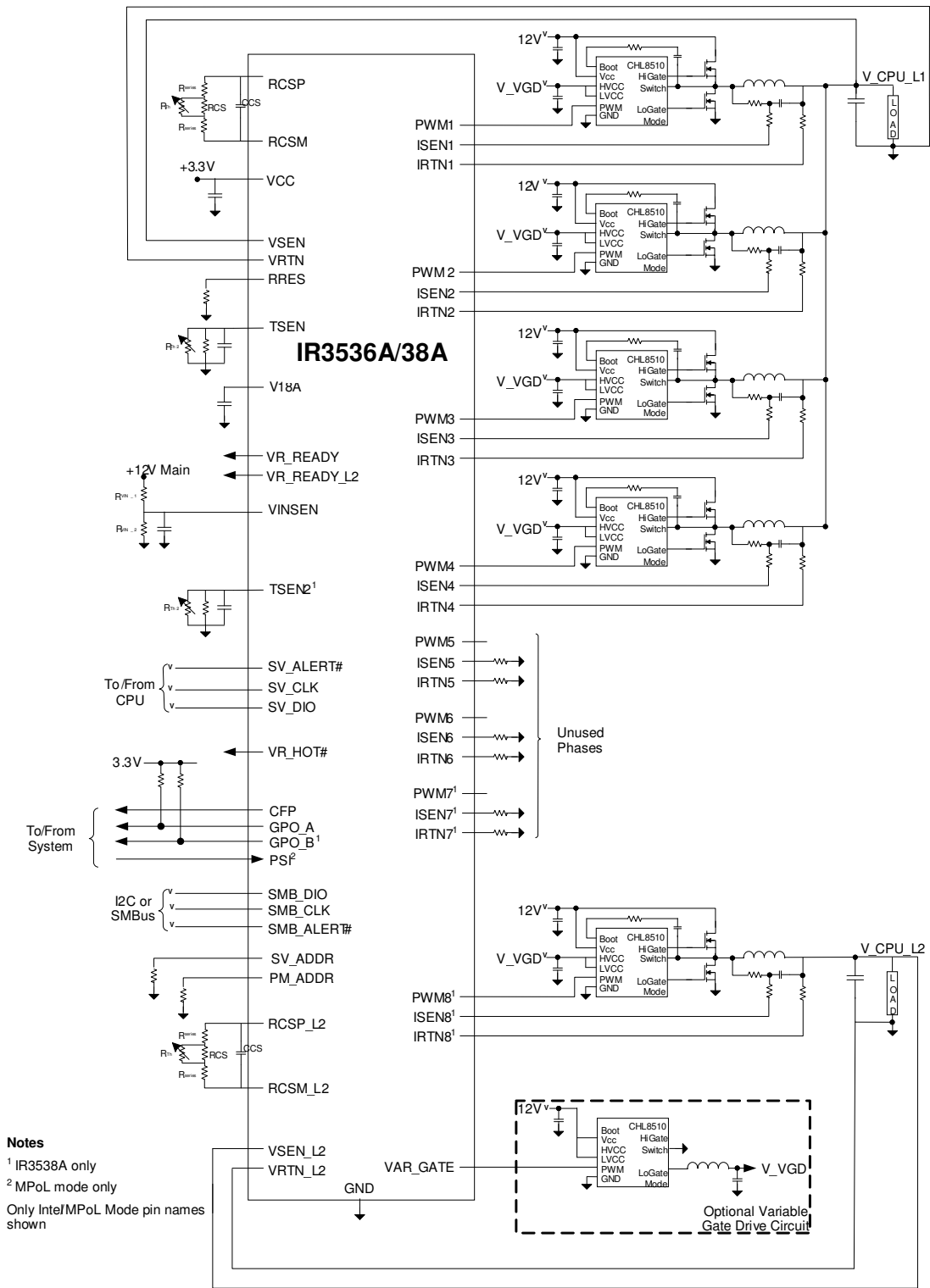

Figure 6: Dual-Loop VRD using IR3536A / IR3538A Controller and CHL8510 MOSFET drivers in 4+1, Intel Mode configuration

Data and specifications subject to change without notice.
This product will be designed and qualified for the Consumer market.
Qualification Standards can be found on IR's Web site.

International
IR Rectifier

IR WORLD HEADQUARTERS: 233 Kansas St., El Segundo, California 90245, USA Tel: (310) 252-710TAC Fax: (310) 252-7903

Visit us at www.irf.com for sales contact information.

www.irf.com