

FEATURES

- Ideal for Server Memory applications using +5V
- Fixed 5V Gate Drive
- Large drivers designed to drive 3nF in $\leq 15\text{ns}$ with +5V drive
 - Low-side driver – 2A source/4A sink
 - High-side driver – 2A source/2A sink
 - Transitions times & Propagation delays $\leq 15\text{ns}$
- Integrated bootstrap diode
- Capable of high switching frequencies from 200kHz up to greater than 1MHz
- Compatible with IR’s patented Active Tri-Level (ATL) PWM for fastest response to transient overshoot
- Non-overlap and under voltage protection
- Thermally enhanced 10-pin DFN package
- Lead free RoHS compliant package
- Low Quiescent power to optimize efficiency

APPLICATIONS

- Multiphase synchronous buck converter for Server CPUs and DDR Memory VR solutions
- High efficiency and compact VRM
- Optimized for Sleep state S3 systems using +5VSB
- Notebook Computer and Graphics VR solutions

DESCRIPTION

The CHL8505 MOSFET is a high-efficiency gate driver which can switch both high-side and low-side N-channel external MOSFETs in a synchronous buck converter. It is intended for use with IR Digital PWM controllers to provide a total voltage regulator (VR) solution for today’s advanced computing applications.

The CHL8505 driver is capable of rapidly switching large MOSFETs with low R_{dson} and large input capacitance used in high-efficiency designs. It is uniquely designed to operate from a 5V source such as a system 5V or 5V standby voltages in sleep states.

The CHL8505 has a unique circuit which improves drive strength to the external MOSFETs even with just 5V supplied at the VDRV pin. This insures faster switching comparable to drivers designed for +12V drive operation. The integrated boot diode reduces external component count. The CHL8505 also features an adaptive non-overlap control for shoot-through protection.

The CHL8505 is configured to drive both the high and low-side switches from the patented IR fast Active Tri-Level (ATL) PWM signal, which will optimize the turn off time of individual phases, optimizing transient performance.

BASIC APPLICATION

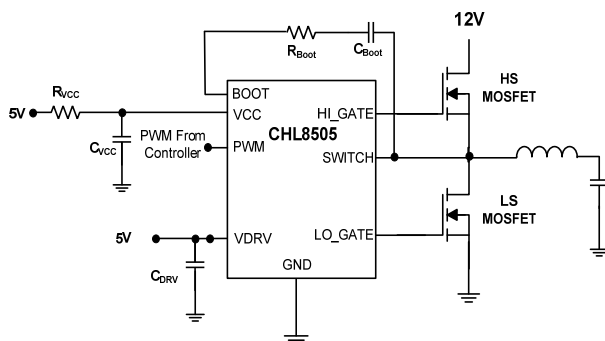

Figure 1: CHL8505 Basic Application Circuit

PIN DIAGRAM

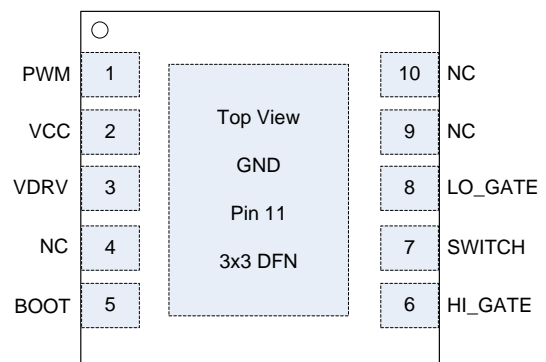
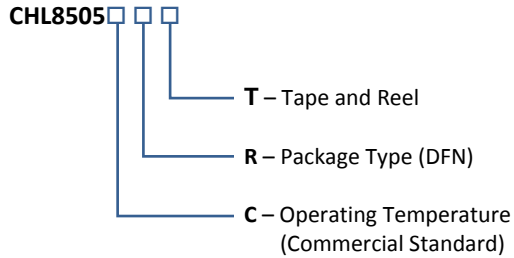

Figure 2: CHL8505 Package Top View

ORDERING INFORMATION



Package	Tape & Reel Qty	Part Number
DFN	3000	CHL8505CRT

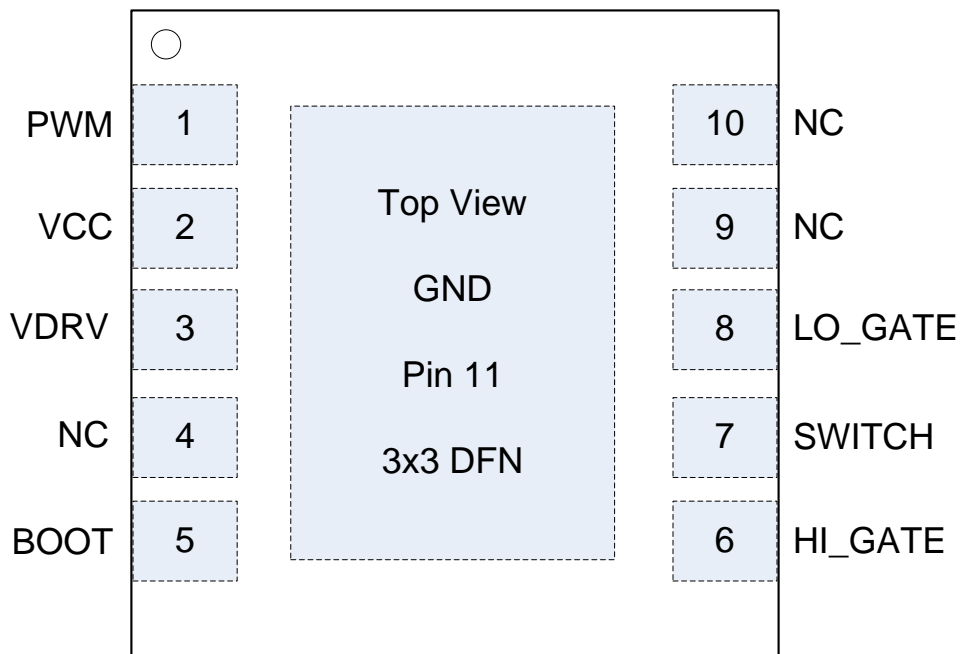

Figure 3: CHL8505 Pin Diagram Enlarged