

IRS4426/IRS4427/IRS4428 DUAL LOW SIDE DRIVER

Features

- Gate drive supply range from 6 V to 20 V
- CMOS Schmitt-triggered inputs
- 3.3V and 5V logic compatible
- Two independent gate drivers
- Matched propagation delay for both channels
- Outputs in phase with inputs
- Leadfree, RoHS compliant

Typical Applications

- General Purpose Dual Low Side Driver
- DC-DC converters

Product Summary

Topology	General Driver
V_{OUT}	6V - 20V
I_{o+} & I_{o-} (typical)	2.3A & 3.3A
t_{on} & t_{off} (typical)	50ns & 50ns

Package Type



Typical Connection Diagram

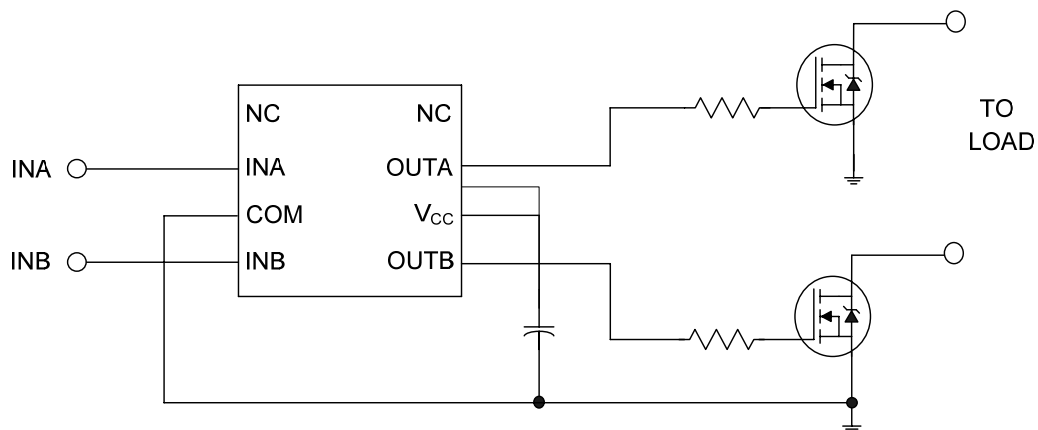

(Refer to Lead Assignments for correct pin configuration). This/These diagram(s) show electrical connections only. Please refer to our Application Notes and Design Tips for proper circuit board layout.

Table of Contents	Page
Typical connection diagram	1
Description	3
Qualification Information	4
Absolute Maximum Ratings	5
Recommended Operating Conditions	5
Static Electrical Characteristics	6
Dynamic Electrical Characteristics	7
Functional Block Diagram	8
Input/Output Pin Equivalent Circuit Diagram	10
Lead Definitions	11
Lead Assignments	11
Application Information and Additional Details	12
Package Details: SOIC8	14
Package Details: SOIC8, Tape and Reel	15
Part Marking Information	16
Ordering Information	17

Description

The IRS4426/IRS4427/IRS4428 are low voltage, high speed power MOSFET and IGBT drivers. Proprietary latch immune CMOS technologies enable ruggedized monolithic construction. The logic input is compatible with standard CMOS or LSTTL output. The output drivers feature a high pulse current buffer stage designed for minimum driver cross-conduction. Propagation delays between two channels are matched.

Qualification Information[†]

Qualification Level		Industrial ^{††}
		Comments: This family of ICs has passed JEDEC's Industrial qualification. IR's Consumer qualification level is granted by extension of the higher Industrial level.
Moisture Sensitivity Level		MSL2 ^{†††} 260°C (per IPC/JEDEC J-STD-020)
ESD	Machine Model	Class B (per JEDEC standard JESD22-A115)
	Human Body Model	Class 3A (per EIA/JEDEC standard EIA/JESD22-A114)
IC Latch-Up Test		Class I, Level A (per JESD78)
RoHS Compliant		Yes

† Qualification standards can be found at International Rectifier's web site <http://www.irf.com/>

†† Higher qualification ratings may be available should the user have such requirements. Please contact your International Rectifier sales representative for further information.

††† Higher MSL ratings may be available for the specific package types listed here. Please contact your International Rectifier sales representative for further information.

Absolute Maximum Ratings

Absolute Maximum Ratings indicate sustained limits beyond which damage to the device may occur. All voltage parameters are absolute voltages referenced to COM. The thermal resistance and power dissipation ratings are measured under board mounted and still air conditions.

Symbol	Definition	Min	Max	Units
V_{CC}	Fixed supply voltage	-0.3	25	V
V_O	Output voltage	-0.3	$V_{CC} + 0.3$	
V_{IN}	Logic input voltage	-0.3	$V_{CC} + 0.3$	
P_D	Package power dissipation @ $T_A \leq 25^\circ\text{C}$	—	0.625	W
R_{thJA}	Thermal resistance, junction to ambient	—	200	$^\circ\text{C}/\text{W}$
T_J	Junction temperature	—	150	$^\circ\text{C}$
T_S	Storage temperature	-55	150	
T_L	Lead temperature (soldering, 10 seconds)	—	300	

Recommended Operating Conditions

For proper operation, the device should be used within the recommended conditions. All voltage parameters are absolute voltages referenced to COM unless otherwise stated in the table. The offset rating is tested with supply of $V_{CC} = 15\text{V}$.

Symbol	Definition	Min	Max	Units
V_{CC}	Fixed supply voltage	6	20	V
V_O	Output voltage	0	V_{CC}	
V_{IN}	Logic input voltage	0	V_{CC}	
T_A	Ambient temperature	-40	125	$^\circ\text{C}$

Static Electrical Characteristics

$V_{CC} = 15V$, $T_A = 25^\circ C$ unless otherwise specified. The V_{IN} and I_{IN} parameters are referenced to COM and are applicable to input leads: INA and INB. The V_O and I_O parameters are referenced to COM and are applicable to the output leads: OUTA and OUTB.

Symbol	Definition	Min	Typ	Max	Units	Test Conditions
V_{IH}	Logic "0" input voltage (OUTA = LO, OUTB = LO) (IRS4426)	2.5	—	—	V	
	Logic "1" input voltage (OUTA=HI,OUTB=HI) (IRS4427)					
	Logic "0" input voltage (OUTA=LO), Logic "1" input voltage (OUTB=HI) (IRS4428)					
V_{IL}	Logic "1" input voltage (OUTA = HI, OUTB = HI) (IRS4426)	—	—	0.8	V	
	Logic "0" input voltage (OUTA=LO,OUTB=LO) (IRS4427)					
	Logic "1" input voltage (OUTA=HI), Logic "0" input voltage (OUTB=LO) (IRS4428)					
V_{OH}	High level output voltage, $V_{BIAS} - V_O$	—	—	1.4		$I_O = 0\text{ mA}$
V_{OL}	Low level output voltage, V_O	—	—	0.15		$I_O = 20\text{ mA}$
I_{IN+}	Logic "1" input bias current	—	5	15	μA	$V_{IN} = 0V$ (IRS4426) $V_{IN} = 5V$ (IRS4427) $V_{INA} = 0V$ (IRS4428) $V_{INB} = 5V$ (IRS4428)
I_{IN-}	Logic "0" input bias current	-30	-10	—		$V_{IN} = 5V$ (IRS4426) $V_{IN} = 0V$ (IRS4427) $V_{INA} = 5V$ (IRS4428) $V_{INB} = 0V$ (IRS4428)
I_{QCC}	Quiescent V_{CC} supply current	—	100	200		$V_{IN} = 0V$ or $5V$
I_{O+}	Output high short circuit pulsed current	—	2.3	—	A	$V_O = 0V$, $V_{IN} = COM$ (IRS4426) $V_O = 0V$, $V_{IN} = 5V$ (IRS4427) $V_O = 0V$, $V_{INA} = COM$ (IRS4428) $V_O = 0V$, $V_{INB} = 5V$ (IRS4428)
I_{O-}	Output low short circuit pulsed current	—	3.3	—		$V_O = 15V$, $V_{IN} = 5V$ (IRS4426) $V_O = 15V$, $V_{IN} = COM$ (IRS4427) $V_O = 15V$, $V_{INA} = 5V$ (IRS4428) $V_O = 15V$, $V_{INB} = COM$ (IRS4428)

Dynamic Electrical Characteristics

$V_{CC} = 15V$, $T_A = 25^\circ C$, and $C_L = 1000pF$ unless otherwise specified.

Symbol	Definition	Min	Typ	Max	Units	Test Conditions
t_{on}	Turn-on propagation delay	—	50	95	ns	Figure 2
t_{off}	Turn-off propagation delay	—	50	95		
t_r	Turn-on rise time	—	25	55		
t_f	Turn-off fall time	—	25	55		

Functional Block Diagram

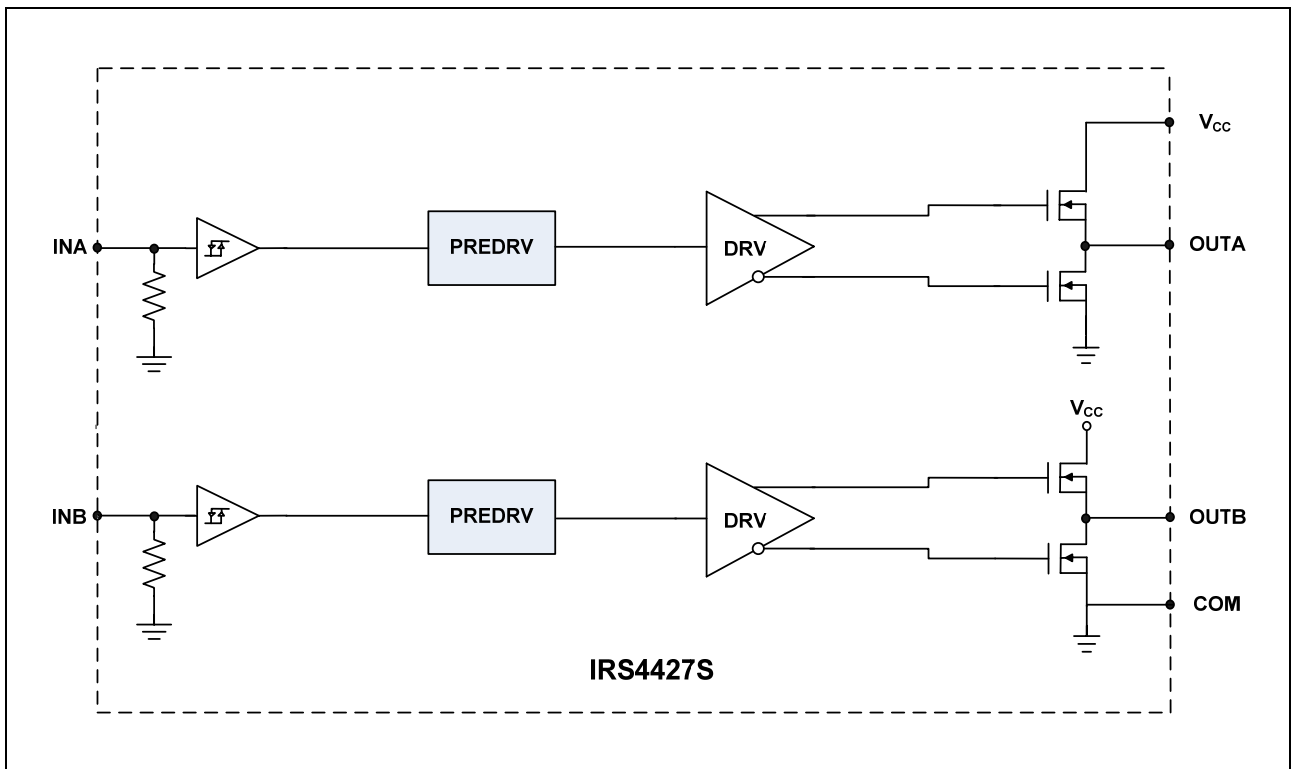
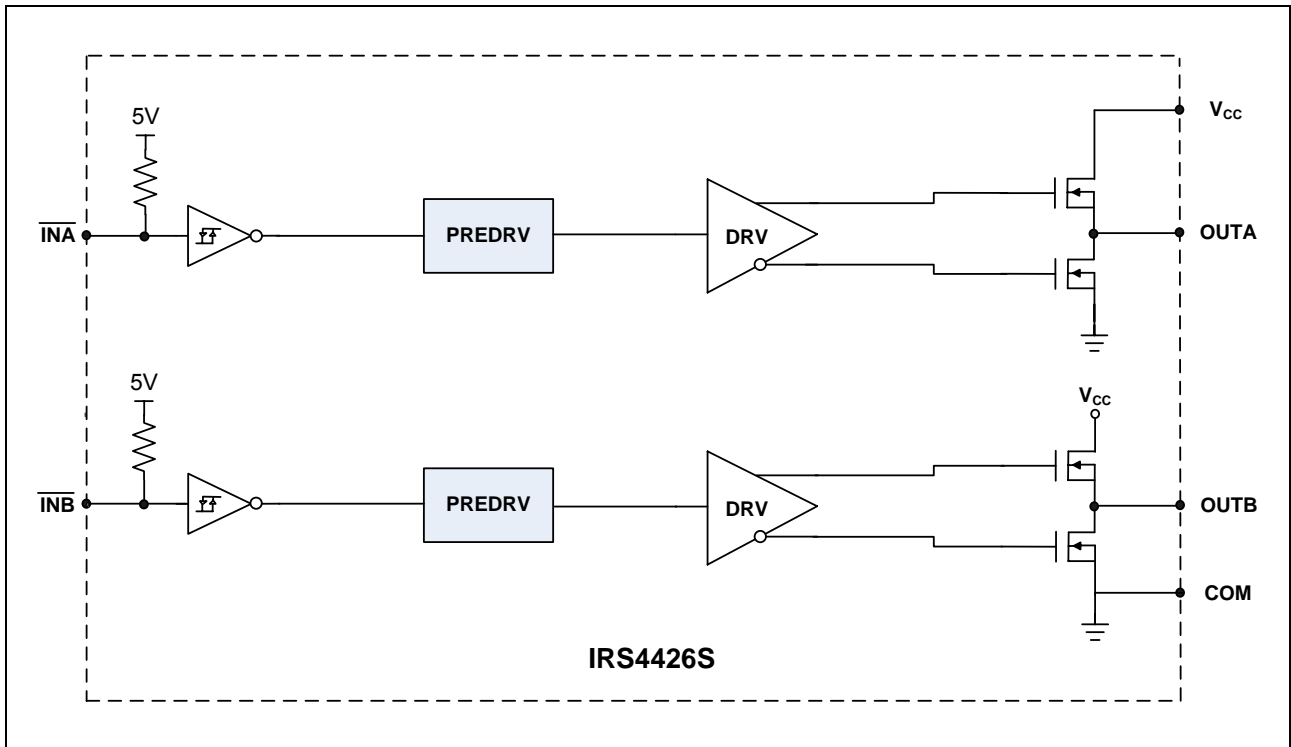

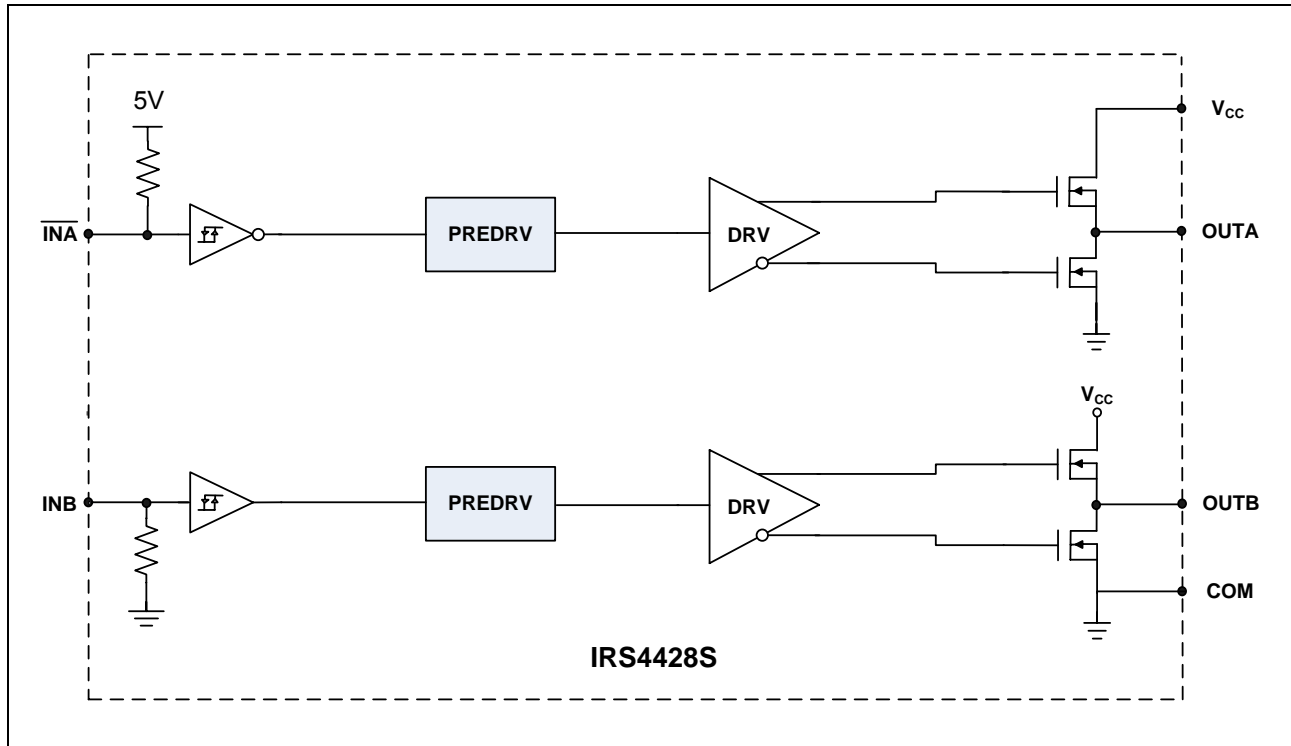

Input/Output Pin Equivalent Circuit Diagrams

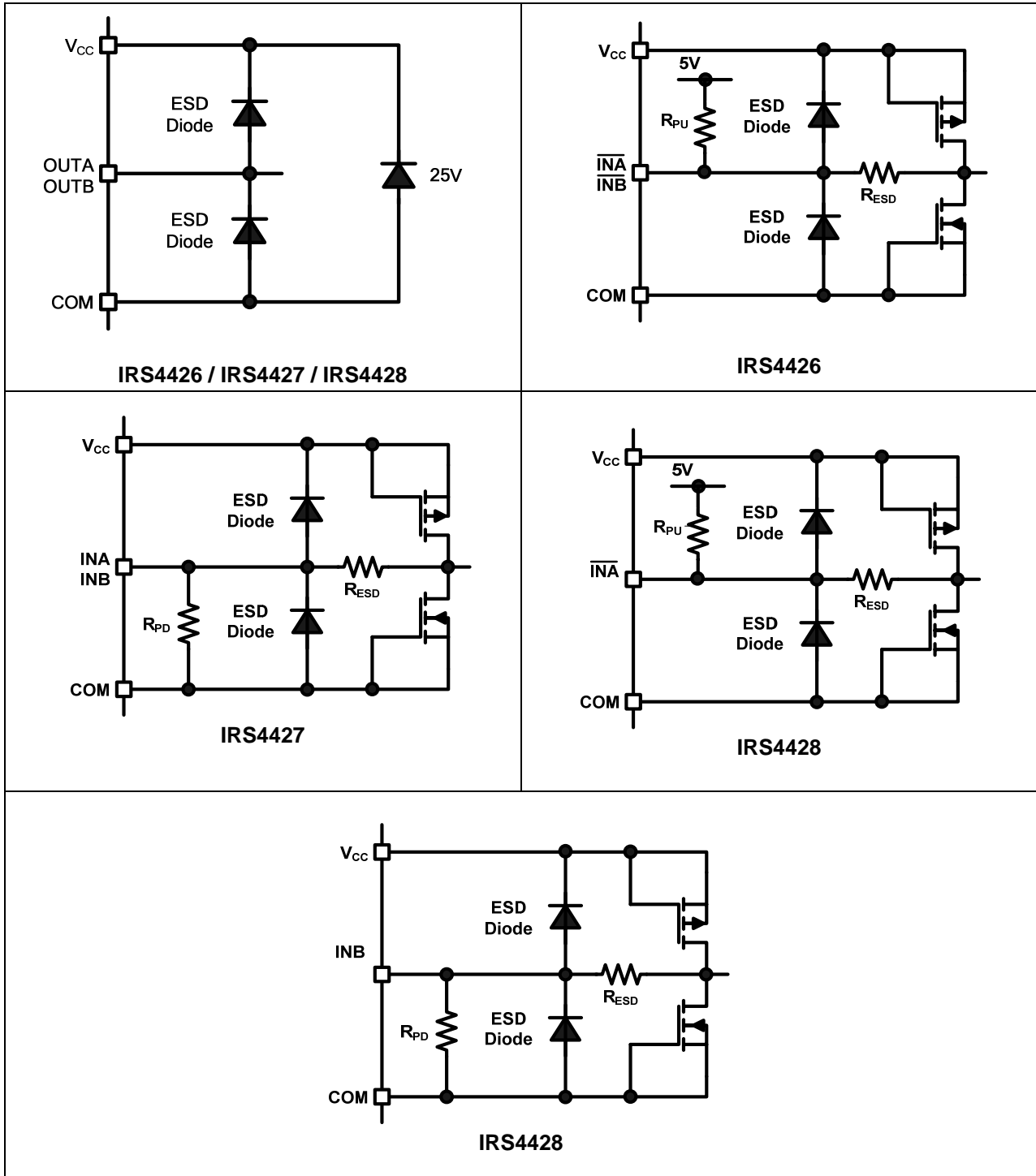

Lead Definitions

PIN	Symbol	Description
1	NC	No connection
2	INA	Logic input for gate driver output (OUTA), out of phase (IRS4426, IRS4428), in phase (IRS4427)
3	GND	Ground
4	INB	Logic input for gate driver output (OUTB), out of phase (IRS4426), in phase (IRS4427, IRS4428)
5	OUTB	Gate drive output B
6	V _{CC}	Supply voltage
7	OUTA	Gate drive output A
8	NC	No connection

Lead Assignments

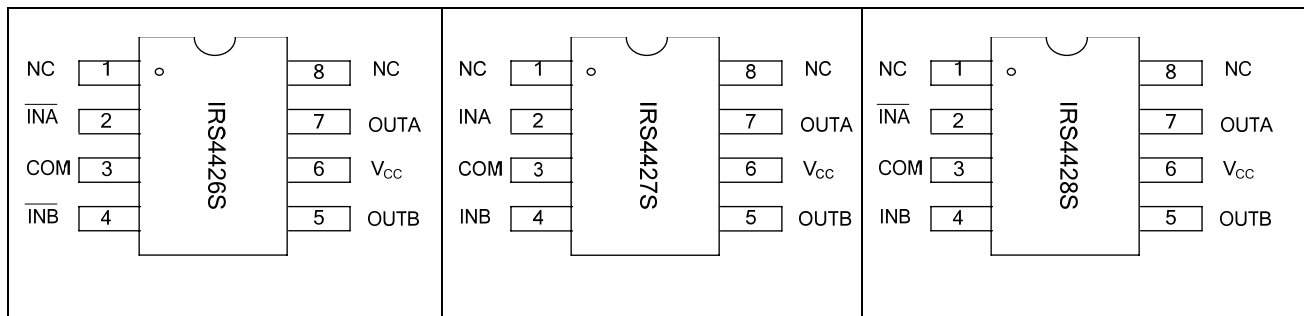

Application Information and Additional Details

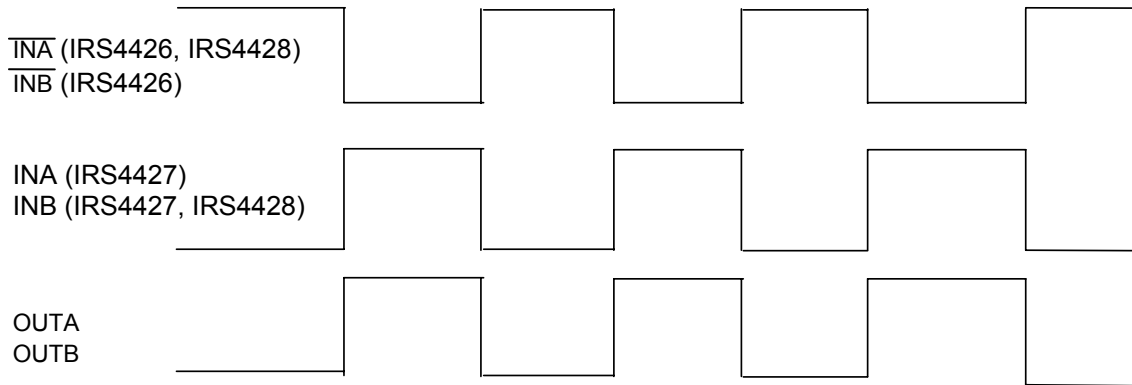

Figure 1: Input/output Timing Diagram

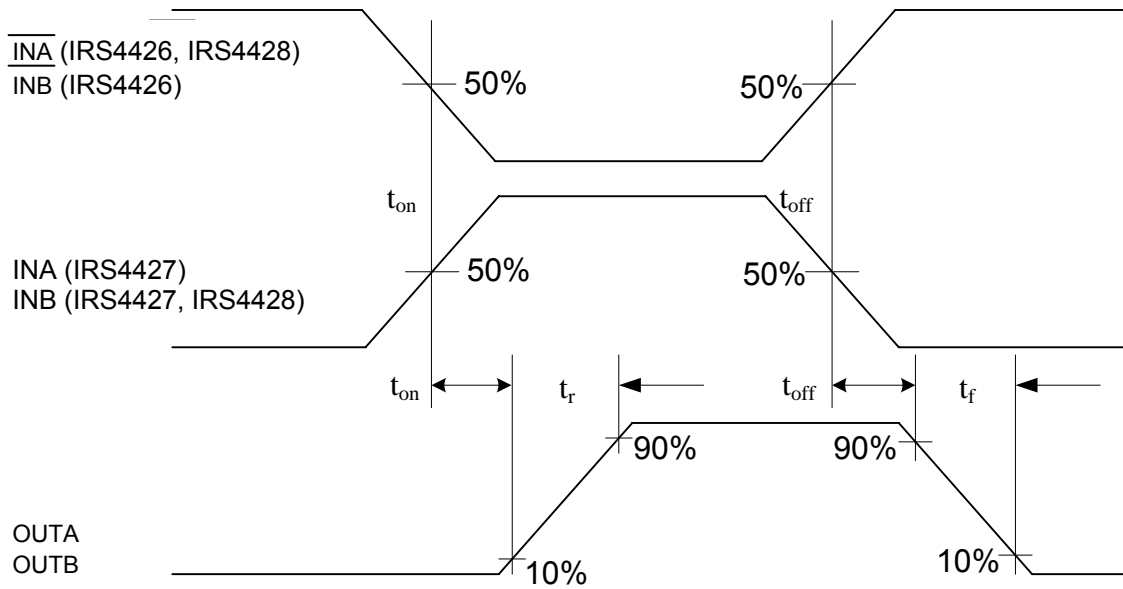

Figure 2: Switching Time Waveform Definitions

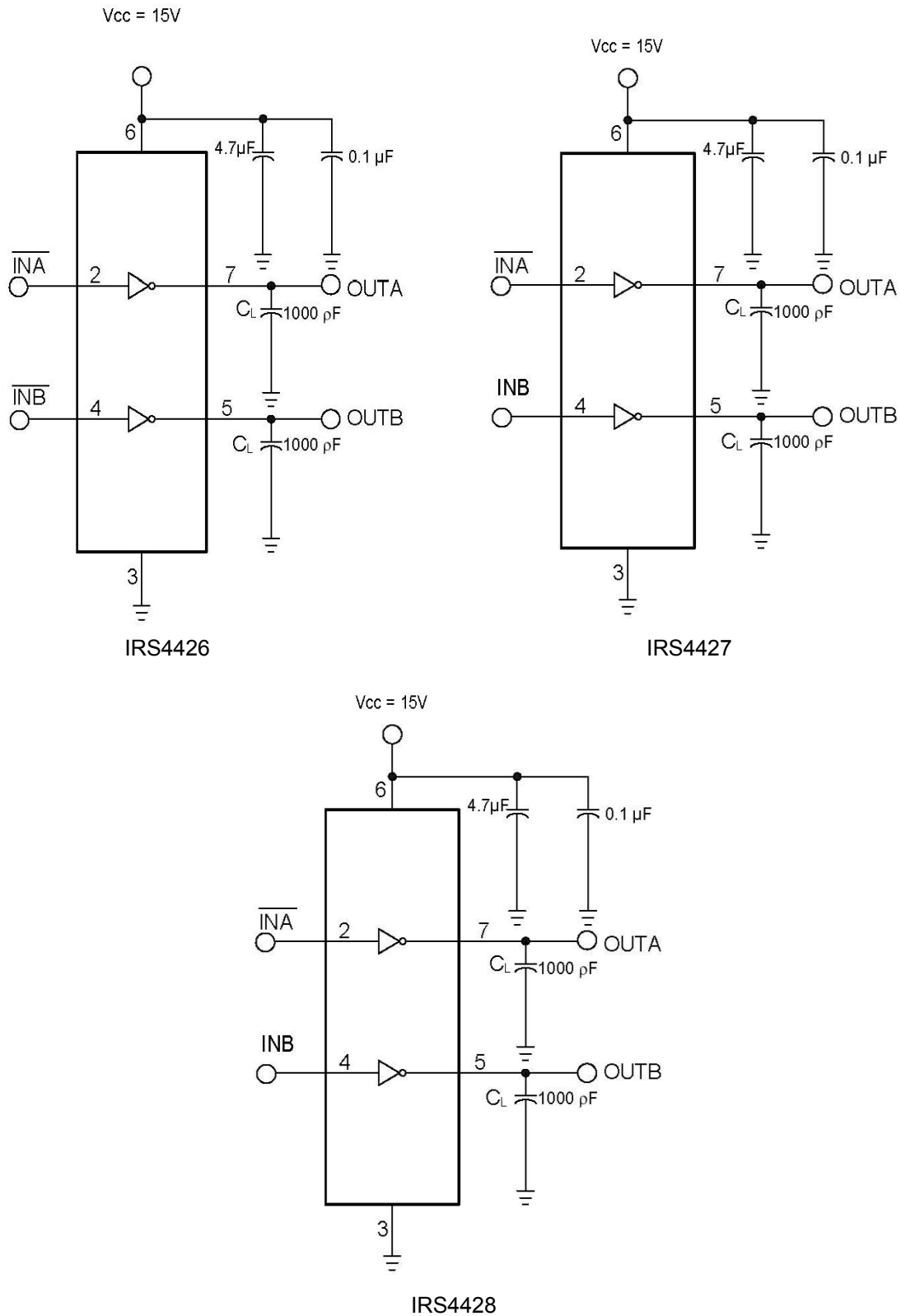
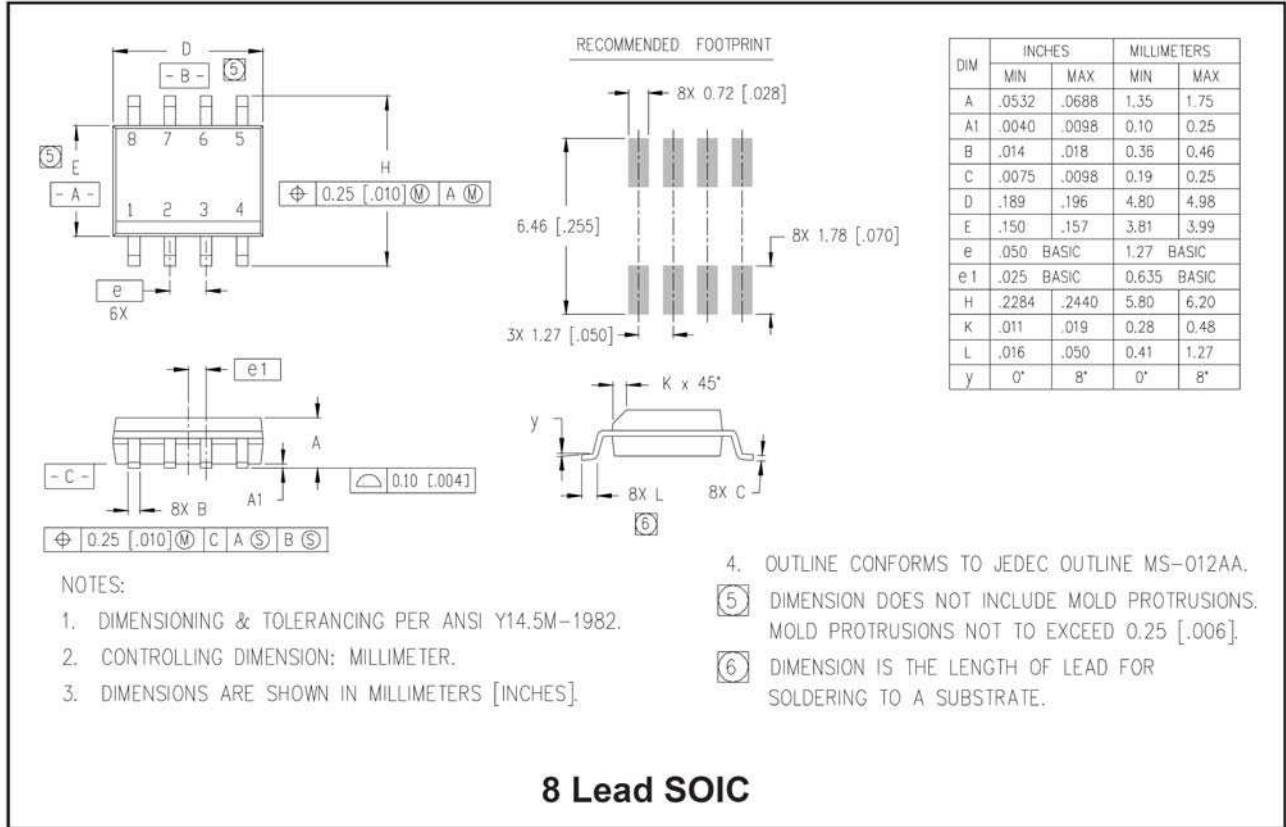
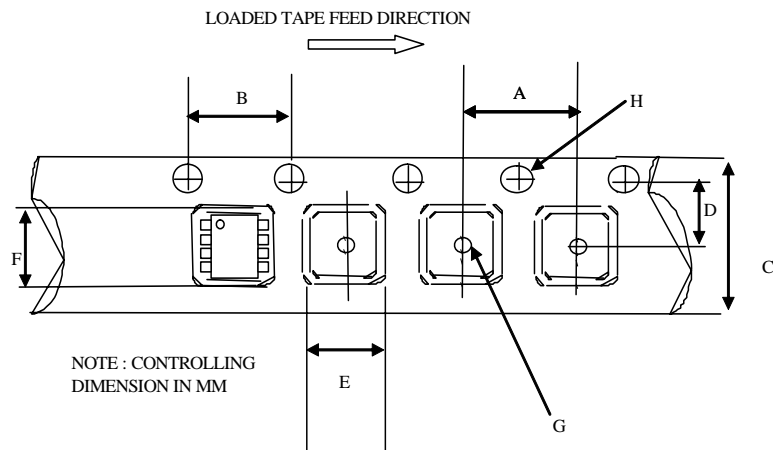

Figure 3: Switching Time Test Circuit

Package Details, SOIC8N



Package details: SOIC8N, Tape and Reel



CARRIER TAPE DIMENSION FOR 8SOICN

Code	Metric		Imperial	
	Min	Max	Min	Max
A	7.90	8.10	0.311	0.318
B	3.90	4.10	0.153	0.161
C	11.70	12.30	0.46	0.484
D	5.45	5.55	0.214	0.218
E	6.30	6.50	0.248	0.255
F	5.10	5.30	0.200	0.208
G	1.50	n/a	0.059	n/a
H	1.50	1.60	0.059	0.062

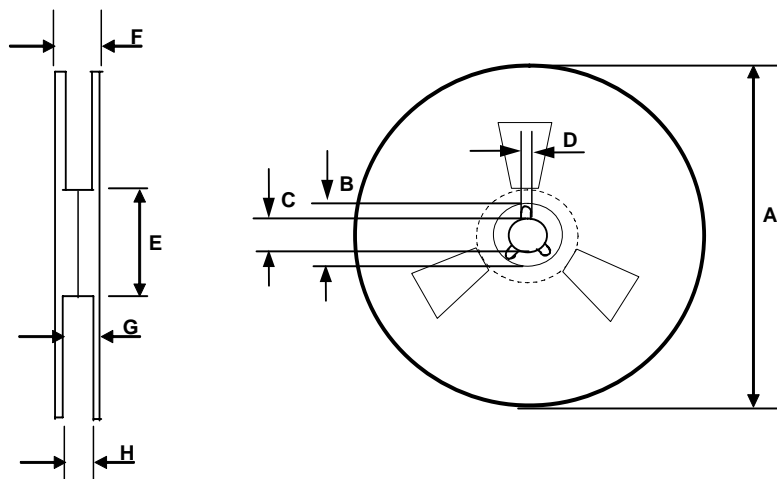

REEL DIMENSIONS FOR 8SOICN

Code	Metric		Imperial	
	Min	Max	Min	Max
A	329.60	330.25	12.976	13.001
B	20.95	21.45	0.824	0.844
C	12.80	13.20	0.503	0.519
D	1.95	2.45	0.767	0.096
E	98.00	102.00	3.858	4.015
F	n/a	18.40	n/a	0.724
G	14.50	17.10	0.570	0.673
H	12.40	14.40	0.488	0.566

Part Marking Information

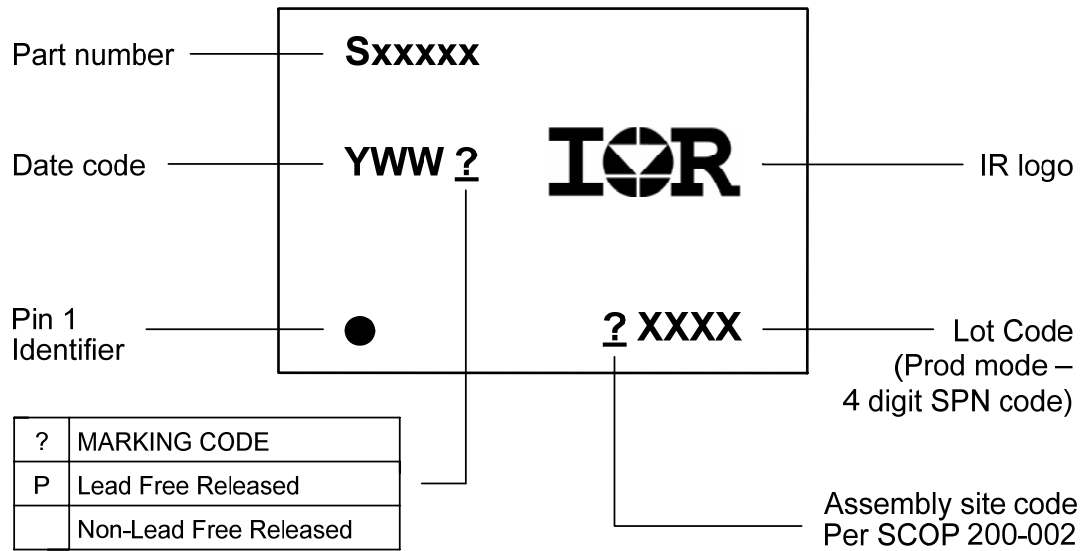

Ordering Information

Base Part Number	Package Type	Standard Pack		Complete Part Number
		Form	Quantity	
IRS4426S	SOIC8N	Tube/Bulk	95	IRS4426SPBF
		Tape and Reel	2500	IRS4426STRPBF
IRS4427S	SOIC8N	Tube/Bluk	95	IRS4427SPBF
		Tape and Reel	2500	IRS4427STRPBF
IRS4428S	SOIC8N	Tube/Bulk	95	IRS4428SPBF
		Tape and Reel	2500	IRS4428STRPBF

The information provided in this document is believed to be accurate and reliable. However, International Rectifier assumes no responsibility for the consequences of the use of this information. International Rectifier assumes no responsibility for any infringement of patents or of other rights of third parties which may result from the use of this information. No license is granted by implication or otherwise under any patent or patent rights of International Rectifier. The specifications mentioned in this document are subject to change without notice. This document supersedes and replaces all information previously supplied.

For technical support, please contact IR's Technical Assistance Center
<http://www.irf.com/technical-info/>

WORLD HEADQUARTERS:
 233 Kansas St., El Segundo, California 90245
 Tel: (310) 252-7105