

## **SupIRBuck™**

### **USER GUIDE FOR IRDC3475 EVALUATION BOARD**

#### **DESCRIPTION**

The IR3475 SupIRBuck™ is an easy-to-use, fully integrated and highly efficient DC/DC voltage regulator. The onboard constant on time hysteretic controller and MOSFETs make IR3475 a space-efficient solution that delivers up to 10A of precisely controlled output voltage. IR3475 is housed in a 4mmx5mm QFN package.

Key features offered by IR3475 include: programmable switching frequency, soft start, temperature compensated over current protection, and thermal shutdown allowing a very flexible solution suitable for many different applications and an ideal choice for battery powered applications.

Additional features include pre-bias startup, a very precise 0.5V reference, forced continuous conduction mode option, over/under voltage protection, power good output, and enable input with voltage monitoring capability.

This user guide contains the schematic, bill of materials, and operating instructions of the IRDC3475 evaluation board. Detailed product specifications, application information and performance curves at different operating conditions are available in the IR3475 data sheet.

---

#### **BOARD FEATURES**

- $V_{IN} = +12V$
- $V_{CC} = +5V$
- $V_{OUT} = +1.05V$
- $I_{OUT} = 0 \text{ to } 10A$
- $F_S = 300kHz @ \text{CCM}$
- $L = 1.5\mu H$
- $C_{IN} = 22\mu F \text{ (ceramic 1210)} + 68\mu F \text{ (electrolytic)}$
- $C_{OUT} = 47\mu F \text{ (ceramic 0805)} + 330\mu F \text{ (POSCAP)}$

**CONNECTIONS and OPERATING INSTRUCTIONS**

An input supply in the range of 8 to 19V should be connected from VIN to PGND. A maximum load of 10A may be connected to V<sub>OUT</sub> and PGND. The connection diagram is shown in Fig. 1, and the inputs and outputs of the board are listed in Table 1.

IRDC3475 has two input supplies, one for biasing (VCC) and the other for input voltage (VIN). Separate supplies should be applied to these inputs. VCC input should be a well regulated 4.5V to 5.5V supply connected to VCC and PGND. Enable (EN) is controlled by the first switch of SW1, and FCCM option can be selected by the second switch of SW1. Toggle the switch to the ON position (marked by a solid square) to enable switching or to select FCCM. The absolute maximum voltage of the external signal applied to EN (TP4) and FCCM is +8V.

**Table 1. Connections**

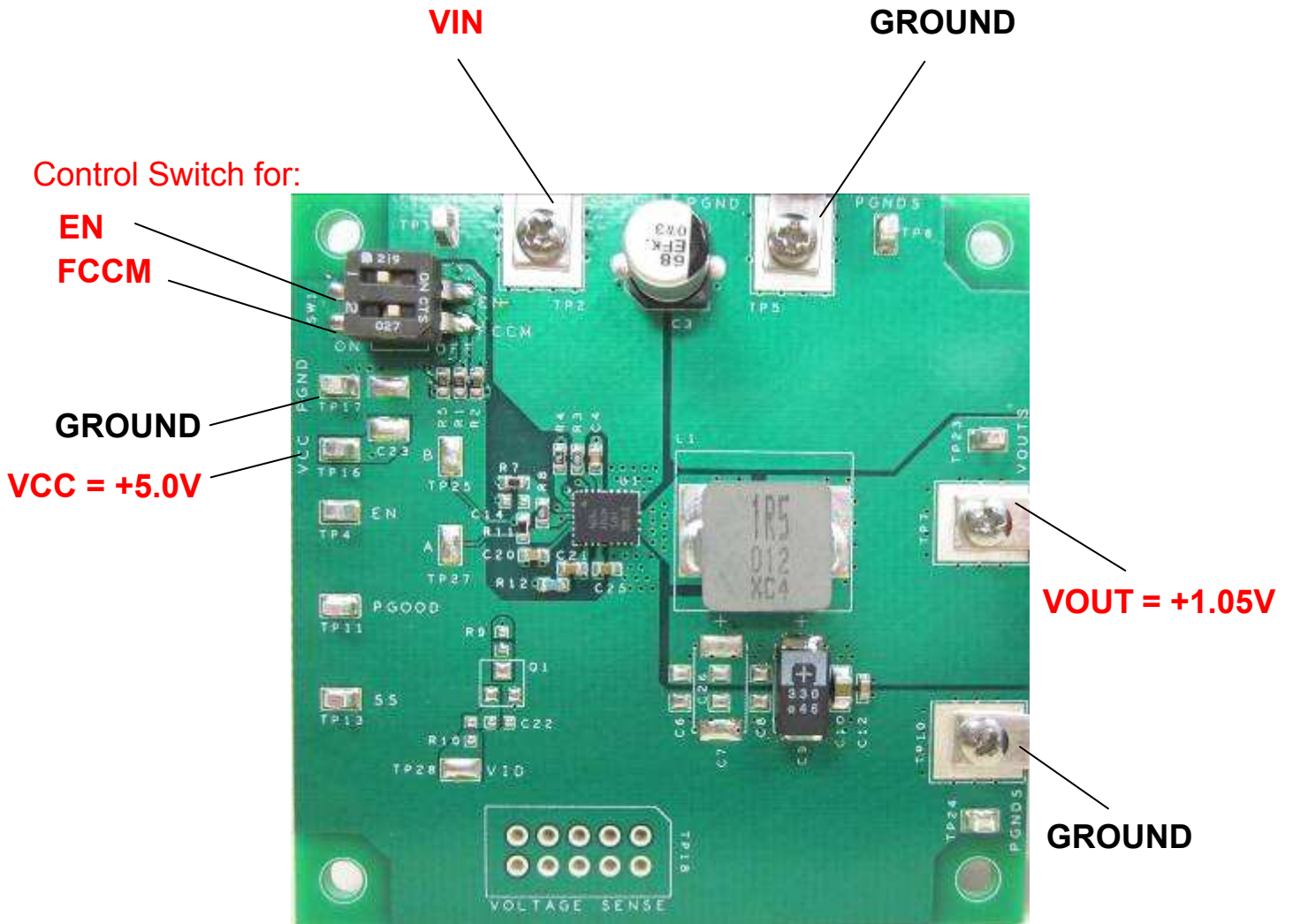
Connection	Signal Name
VIN (TP2)	VIN
PGND (TP5)	Ground for VIN
VCC (TP16)	VCC Input
PGND (TP17)	Ground for VCC Input
VOUT (TP7)	V <sub>OUT</sub> (+1.05V)
PGND (TP10)	Ground for V <sub>OUT</sub>
EN (TP4)	Enable Input

**LAYOUT**

The PCB is a 4-layer board. All layers are 1 oz. copper. IR3475 and other components are mounted on the top and bottom layers of the board.

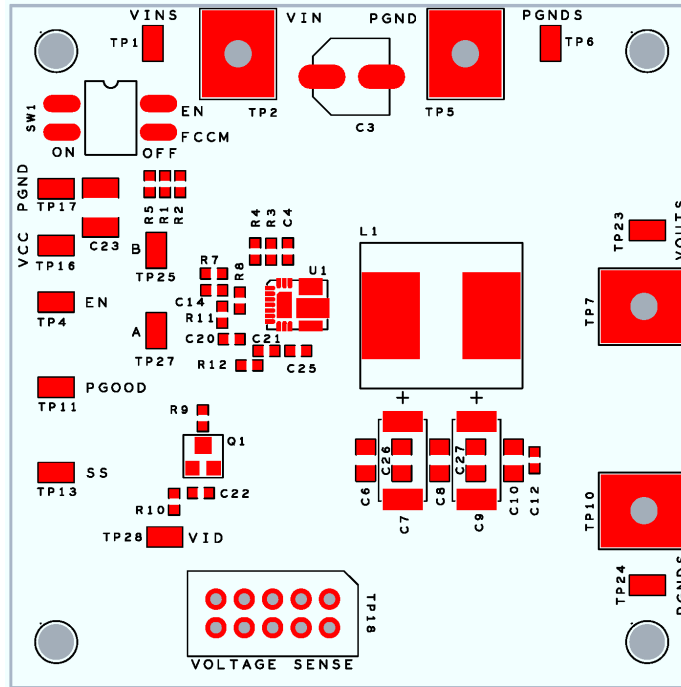
The power supply decoupling capacitors, bootstrap capacitor and feedback components are located close to IR3475. To improve efficiency, the circuit board is designed to minimize the length of the on-board power ground current path.

**CONNECTION DIAGRAM**

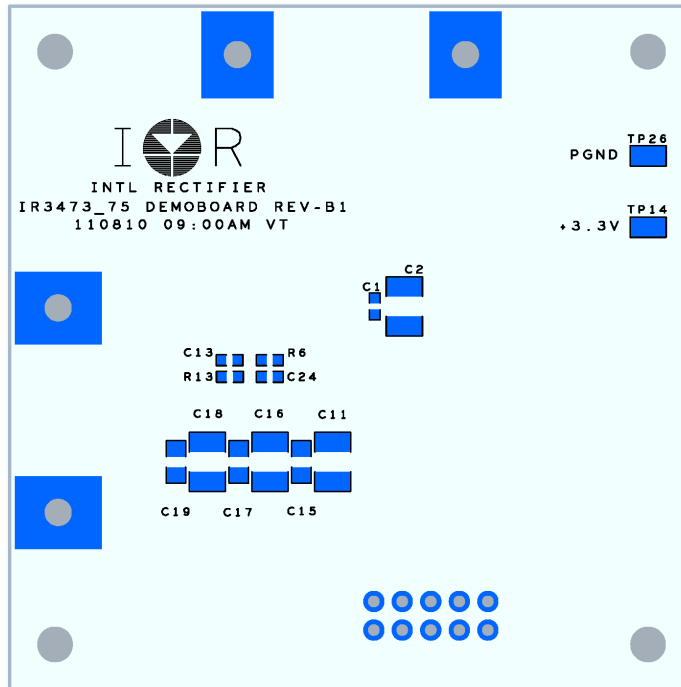


**Fig. 1: Connection Diagram of IRDC3475 Evaluation Board**

**PCB Board Layout**

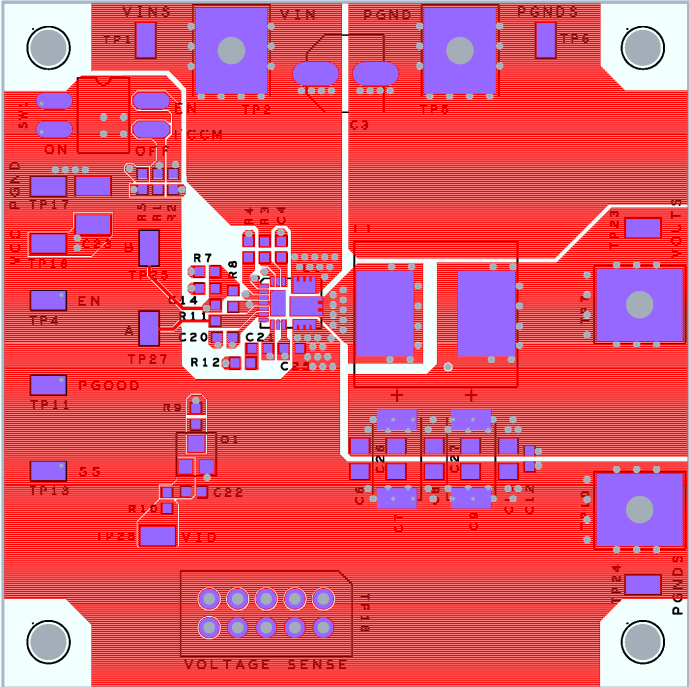


**Fig. 2: Board Layout, Top Components**

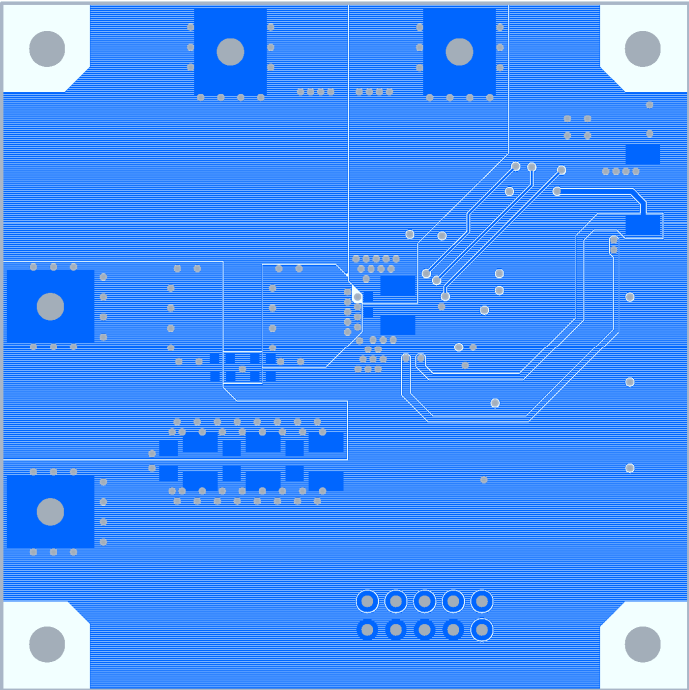


**Fig. 3: Board Layout, Bottom Components**

**PCB Board Layout**

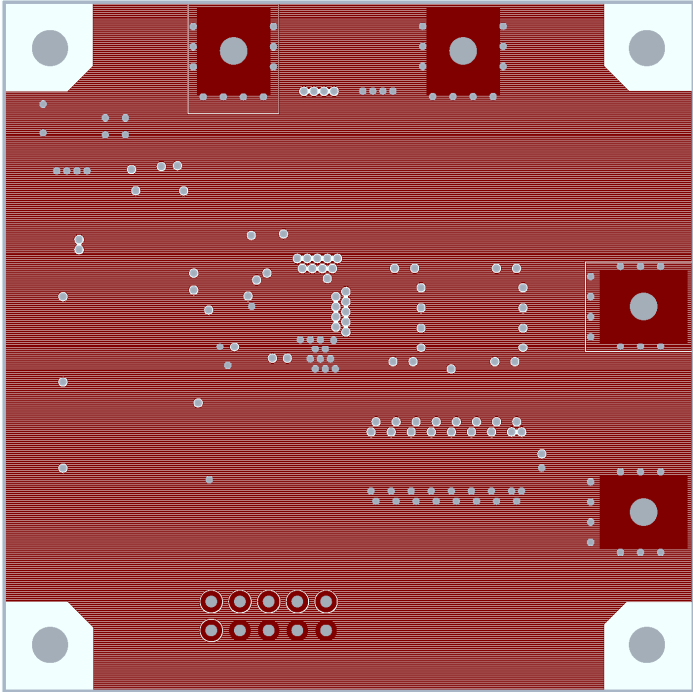


**Fig. 4: Board Layout, Top Layer**

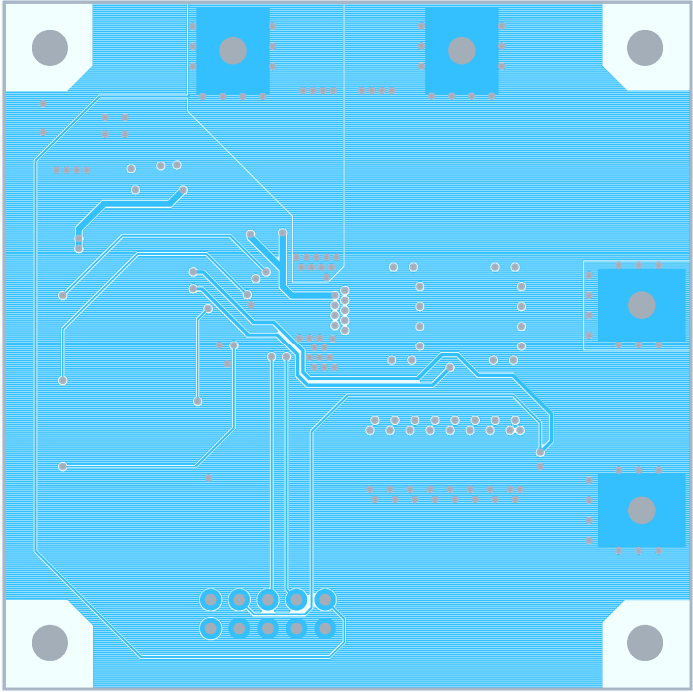


**Fig. 5: Board Layout, Bottom Layer**

**PCB Board Layout**



**Fig. 6: Board Layout, Mid-layer I**



**Fig. 7: Board Layout, Mid-layer II**

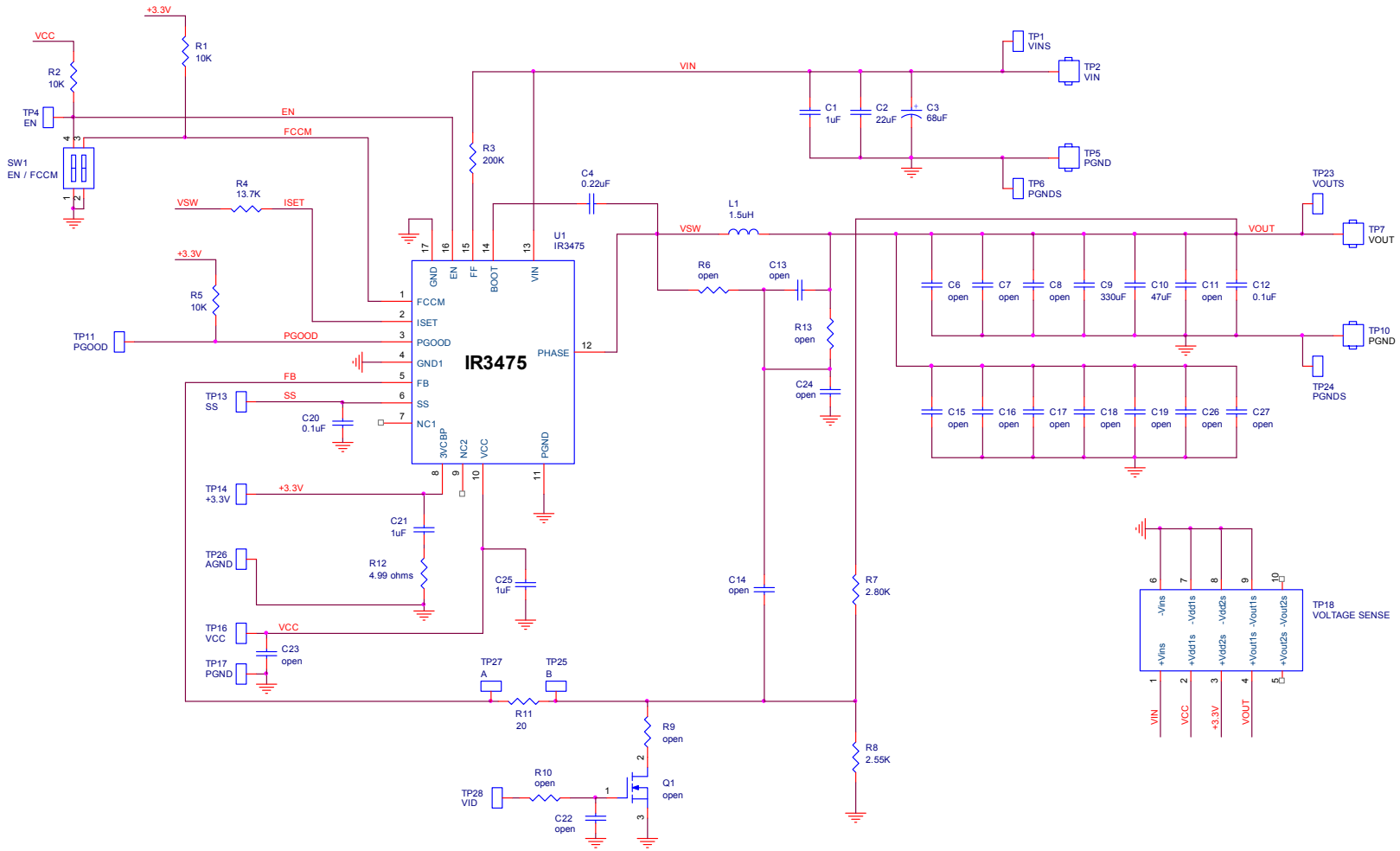


Fig. 8: Schematic of the IRDC3475 Evaluation Board

**Bill of Materials**

QTY	REF DESIGNATOR	VALUE	DESCRIPTION	MANUFACTURER	PART NUMBER
3	C1, C21, C25	1.00uF	capacitor, X7R, 1.00uF, 25V, 0.1, 0603	Murata	GRM188R71E105KA12D
1	C10	47uF	capacitor, 47uF, 6.3V, 805	TDK	C2012X5R0J476M
2	C12, C20	0.100uF	capacitor, X7R, 0.100uF, 25V, 0.1, 603	TDK	C1608X7R1E104K
1	C2	22.0uF	capacitor, X5R, 22.0uF, 16V, 20%, 1206	Taiyo Yuden	EMK316BJ226ML-T
1	C3	68uF	capacitor, electrolytic, 68uF, 25V, 0.2, SMD	Panasonic	EEV-FK1E680P
1	C4	0.22uF	capacitor, X5R, 0.22uF, 10V, 0.1, 0603	TDK	C1608X5R1A224K
1	C9	330uF	capacitor, electrolytic, 330uF, 2.5V, 0.2, 7343	Sanyo	2R5TPE330M9
1	L1	1.5uH	inductor, ferrite, 1.5uH, 16.0A, 3.8mOhm, SMT	Cyntec	PIMB104T-1R5MS-39
3	R1, R2, R5	10.0K	resistor, thick film, 10.0K, 1/10W, 0.01, 0603	KOA	RK73H1J1002F
1	R11	20	resistor, thick film, 20, 1/10W, 0.01, 603	KOA	RK73H1JLTD20R0F
1	R12	4.99	resistor, thick film, 4.99, 1/10W, 0.01, 603	Vishay/Dale	CRCW06034R99FNEA
1	R3	200K	resistor, thick film, 200K, 1/10W, 0.01, 603	KOA	RK73H1JLTD2003F
1	R4	13.7K	resistor, thick film, 13.7K, 1/10W, 0.01, 603	KOA	RK73H1JLTD1372F
1	R7	2.80K	resistor, thick film, 2.80K, 1/10W, 0.01, 603	KOA	RK73H1JLTD2801F
1	R8	2.55K	resistor, thick film, 2.55K, 1/10W, 0.01, 0603	KOA	RK73H1J2551F
1	SW1	SPST	switch, DIP, SPST, 2 position, SMT	C&K Components	SD02H0SK
1	U1	IR3475	4mm X 5mm QFN	IRF	IR3475MTRPBF



## TYPICAL OPERATING WAVEFORMS

Tested with demoboard shown in Fig. 8,  $V_{IN} = 12V$ ,  $V_{CC} = 5V$ ,  $V_{OUT} = 1.05V$ ,  $F_s = 300kHz$ ,  $T_A = 25^\circ C$ , no airflow, unless otherwise specified

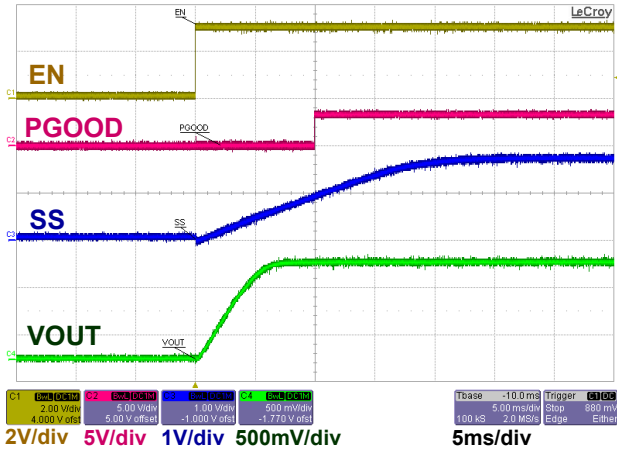


Fig. 9: Startup

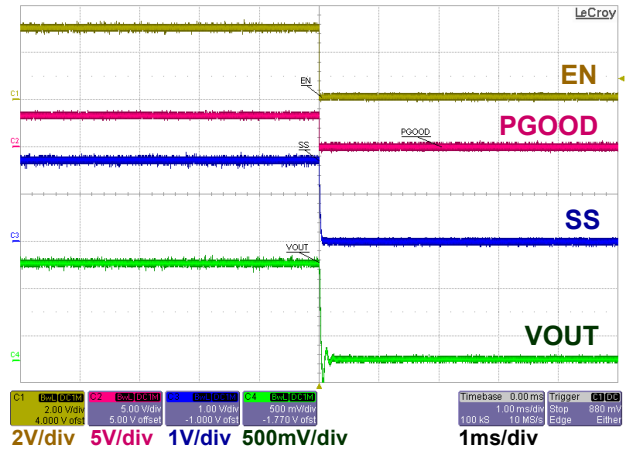


Fig. 10: Shutdown

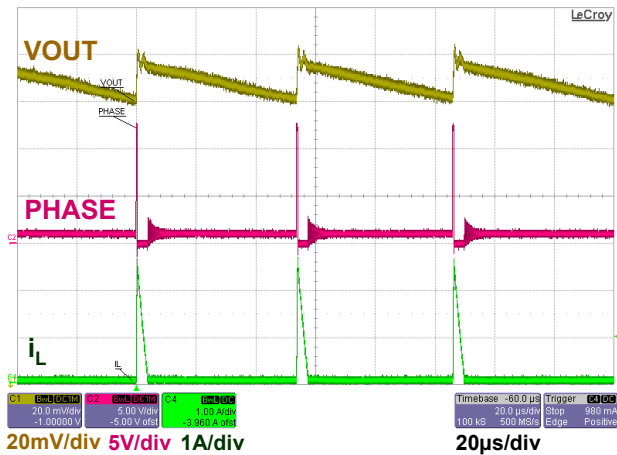


Fig. 11: DCM ( $I_{OUT} = 0.1A$ )

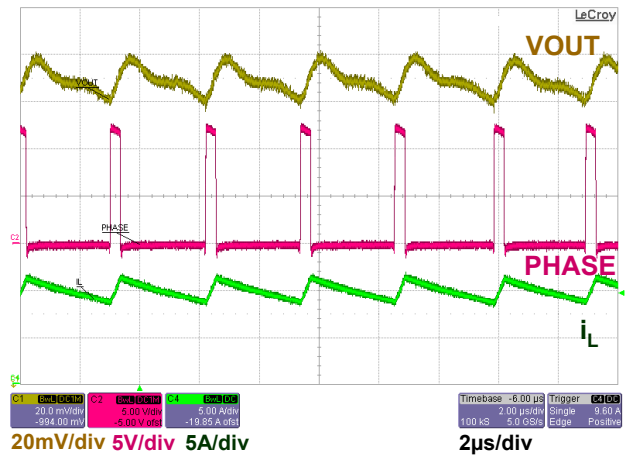


Fig. 12: CCM ( $I_{OUT} = 10A$ )

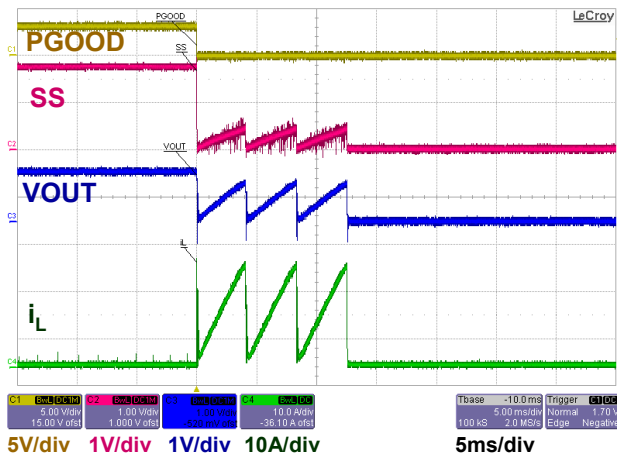


Fig. 13: Over Current Protection (tested by shorting VOUT to PGND)

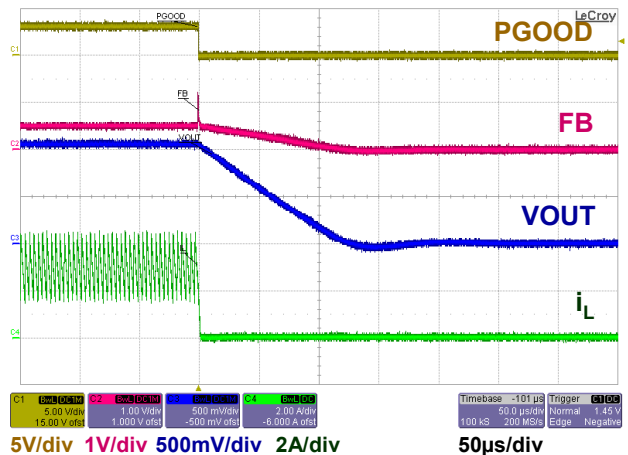
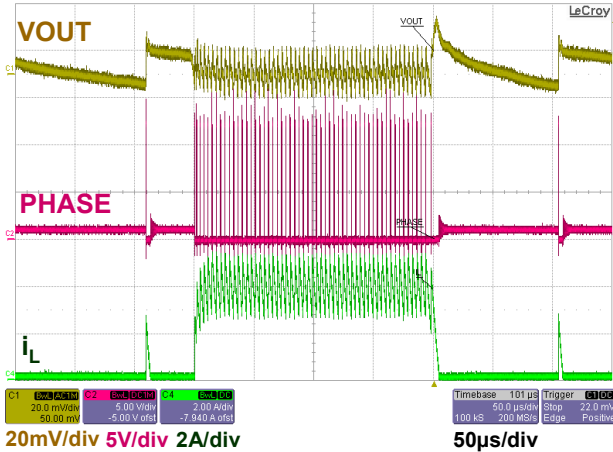


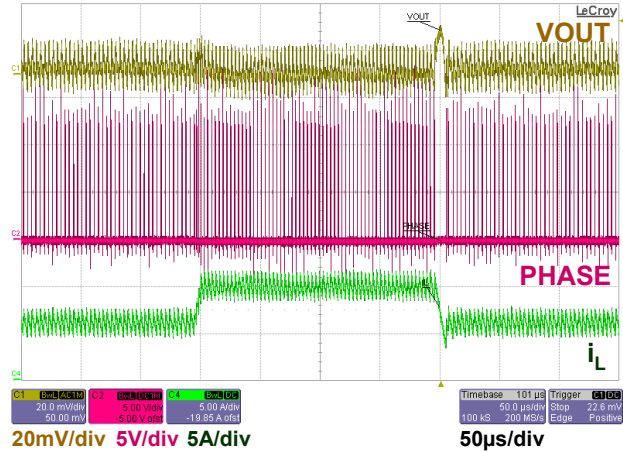
Fig. 14: Over Voltage Protection (tested by shorting FB to VOUT)

**TYPICAL OPERATING WAVEFORMS**

Tested with demoboard shown in Fig. 8, VIN = 12V, VCC = 5V, VOUT = 1.05V, Fs = 300kHz, TA = 25°C, no airflow, unless otherwise specified



**Fig. 15: Load Transient 0-4A**



**Fig. 16: Load Transient 6-10A**

**TYPICAL PERFORMANCE**

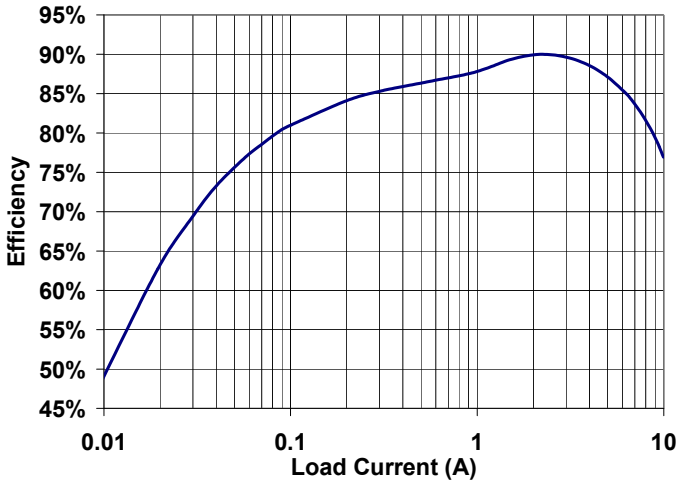
VIN = 12V, VCC = 5V, VOUT = 1.05V, Fs = 300kHz, IOU = 10A, TA = 25°C, no airflow



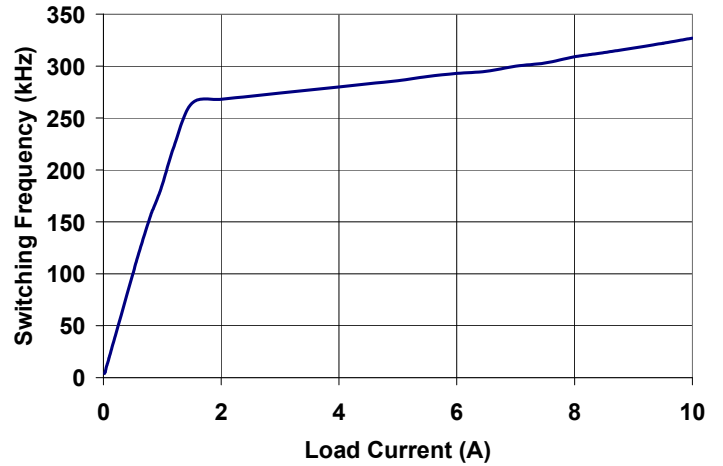
**Fig. 17: Thermal Image (IR3475: 95°C, Inductor: 57°C, PCB: 44°C)**

**TYPICAL OPERATING DATA**

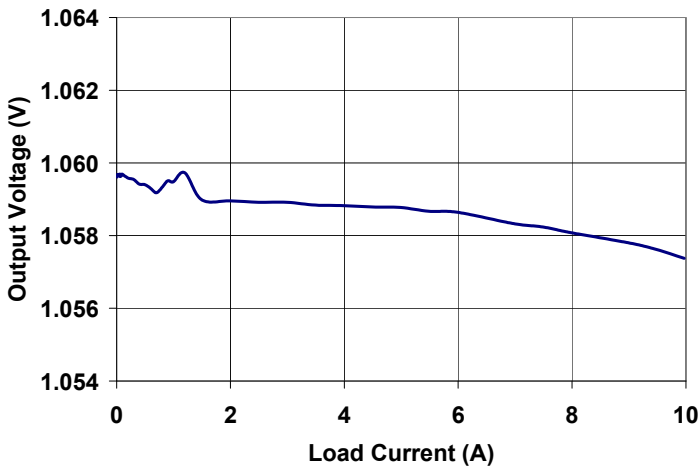
VIN = 12V, VCC = 5V, VOUT = 1.05V, Fs = 300kHz, IOUT = 0 ~ 10A, TA = 25°C, no airflow, unless otherwise specified



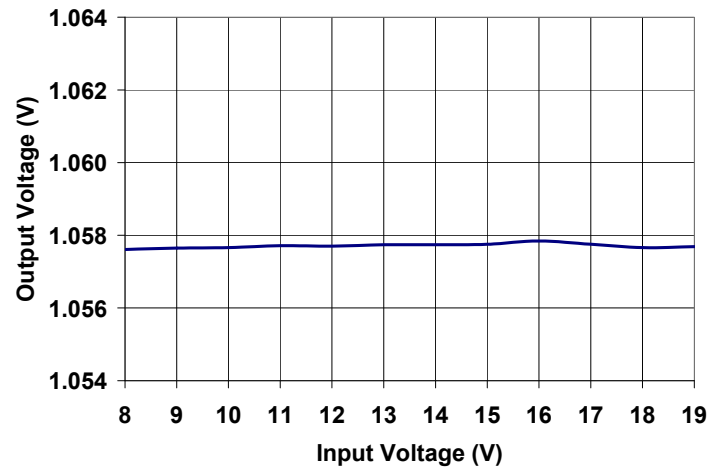
**Fig. 18: Efficiency vs. Output Current**



**Fig. 19: Switching Frequency vs. Output Current**



**Fig. 20: Load Regulation**



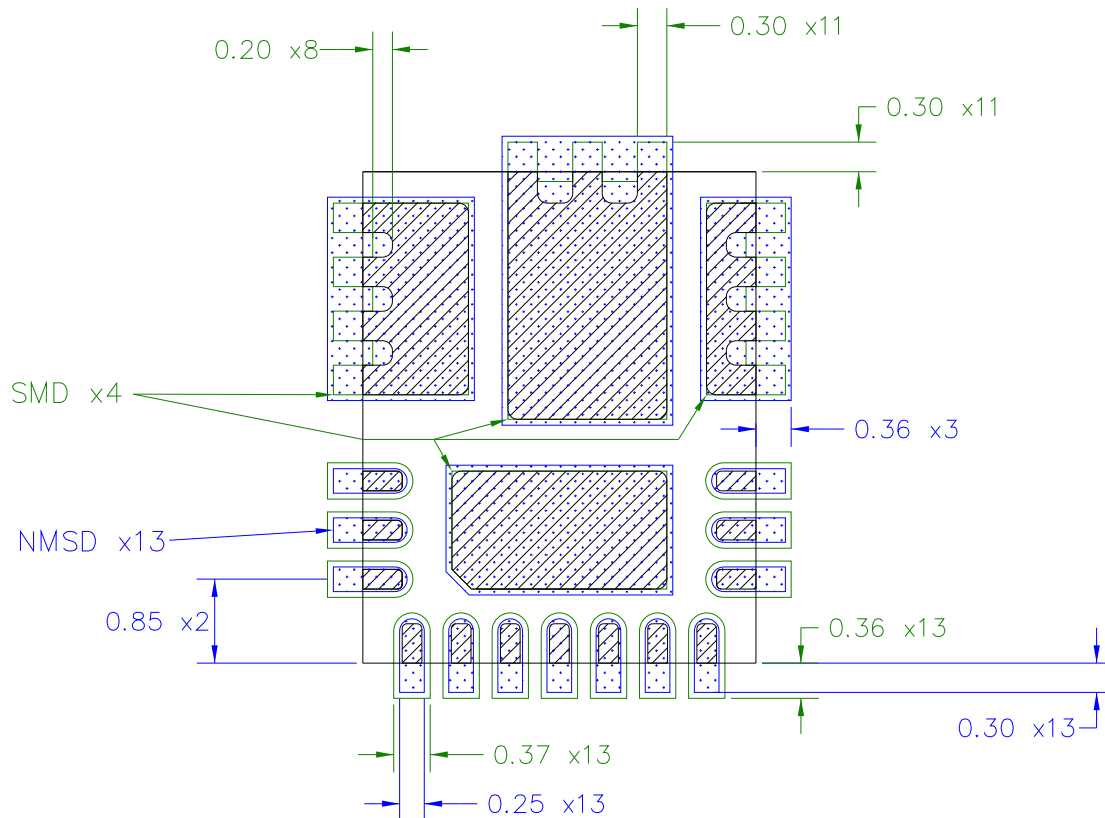
**Fig. 21: Line Regulation at 10A Load**

**PCB Metal and Components Placement**




Lead lands (the 13 IC pins) width should be equal to nominal part lead width. The minimum lead to lead spacing should be  $\geq 0.2\text{mm}$  to minimize shorting.

Lead land length should be equal to maximum part lead length + 0.3 mm outboard extension. The outboard extension ensures a large toe fillet that can be easily inspected.

Pad lands (the 4 big pads) length and width should be equal to maximum part pad length and width. However, the minimum metal to metal spacing should be no less than 0.17mm for 2 oz. Copper, or no less than 0.1mm for 1 oz. Copper, or no less than 0.23mm for 3 oz. Copper.



All Dimensions in mm

-  PCB Copper
-  Component
-  Soldermask

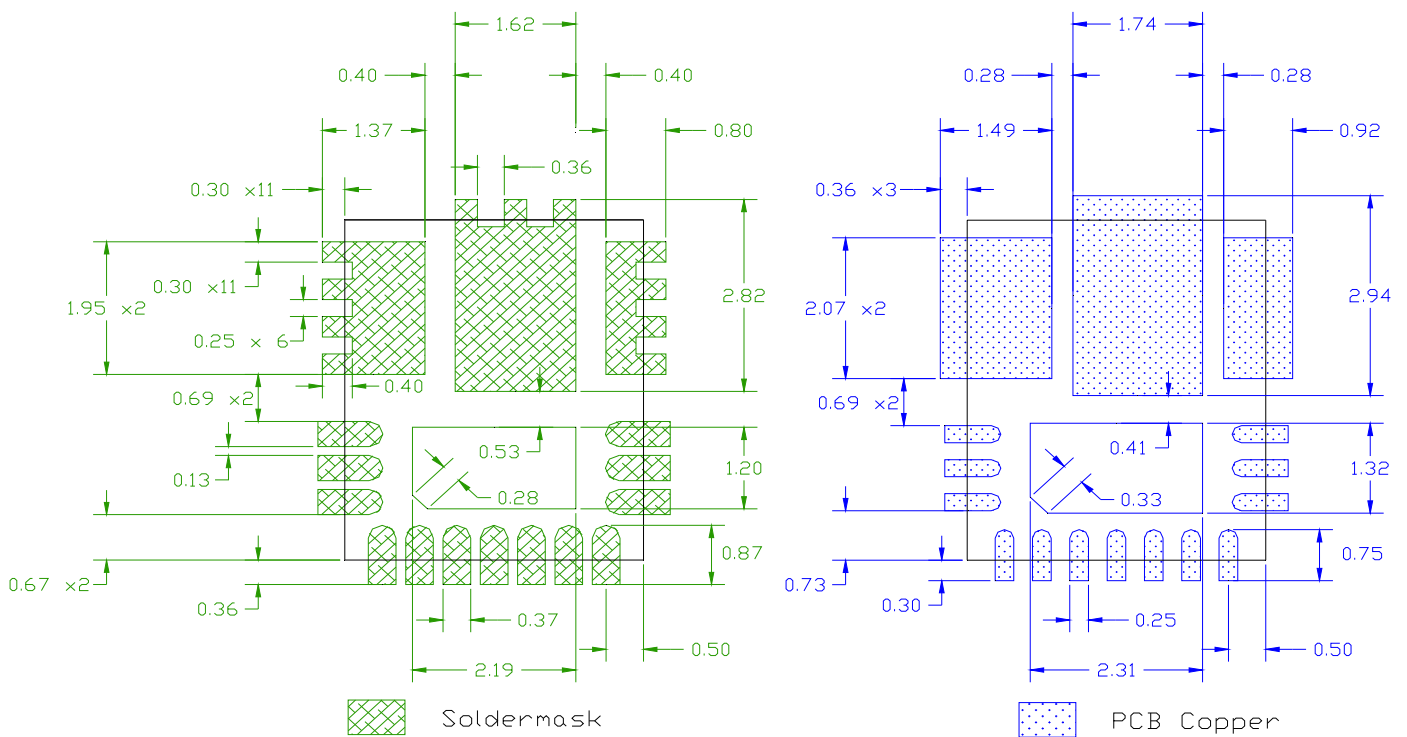
**Solder Resist**

It is recommended that the lead lands are Non Solder Mask Defined (NSMD). The solder resist should be pulled away from the metal lead lands by a minimum of 0.025mm to ensure NSMD pads.

The land pad should be Solder Mask Defined (SMD), with a minimum overlap of the solder resist onto the copper of 0.05mm to accommodate solder resist misalignment.

Ensure that the solder resist in between the lead lands and the pad land is  $\geq 0.15\text{mm}$  due to the high aspect ratio of the solder resist strip separating the lead lands from the pad land.

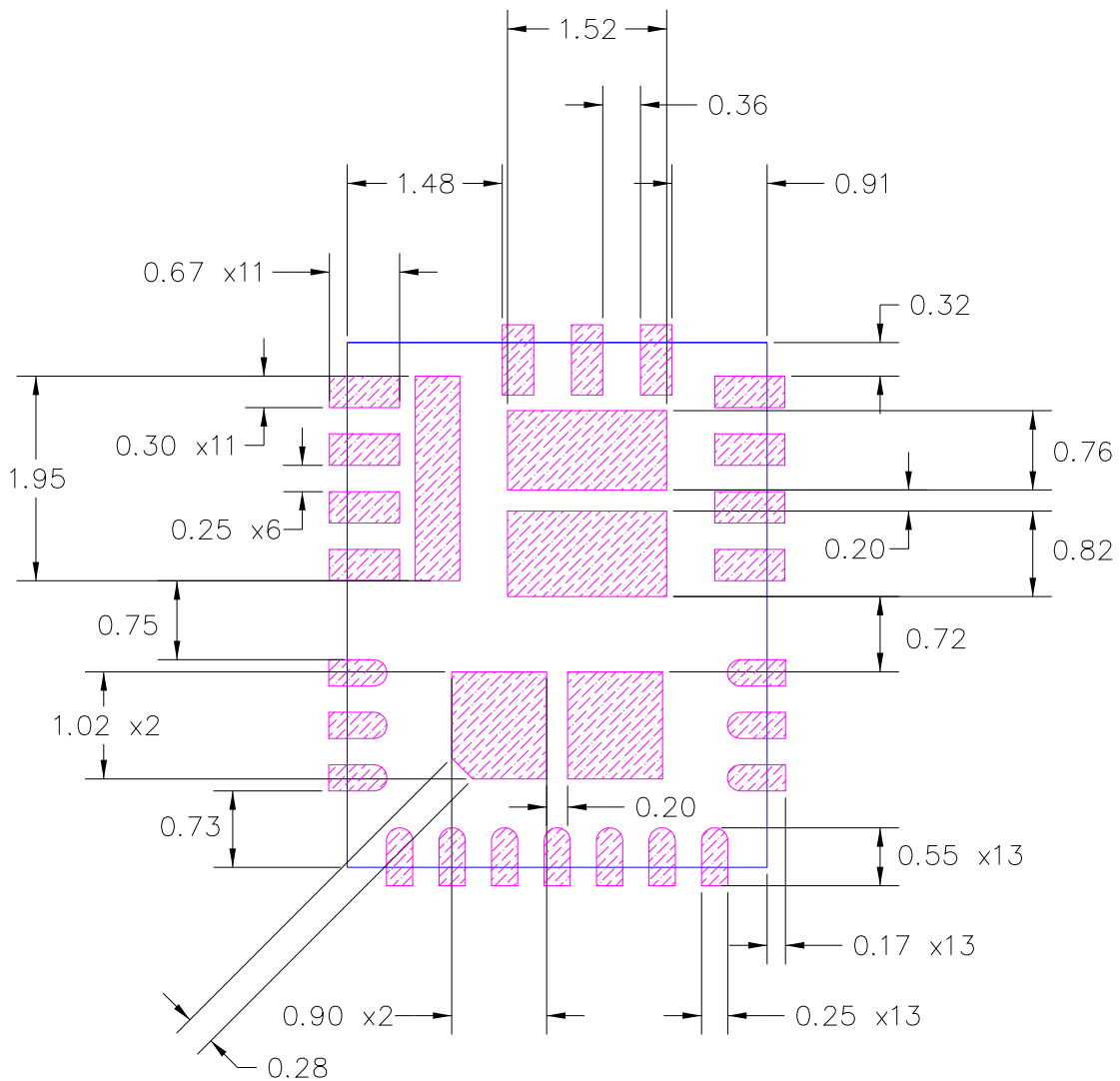
All Dimensions in mm



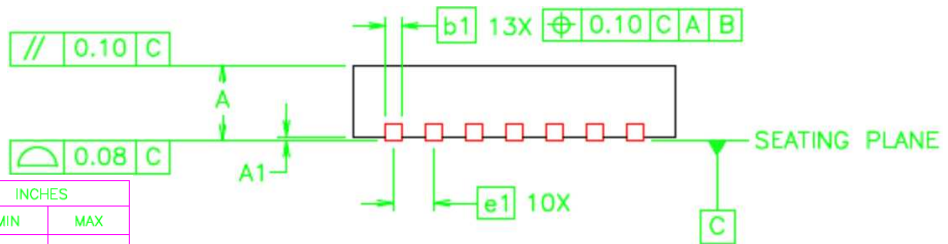
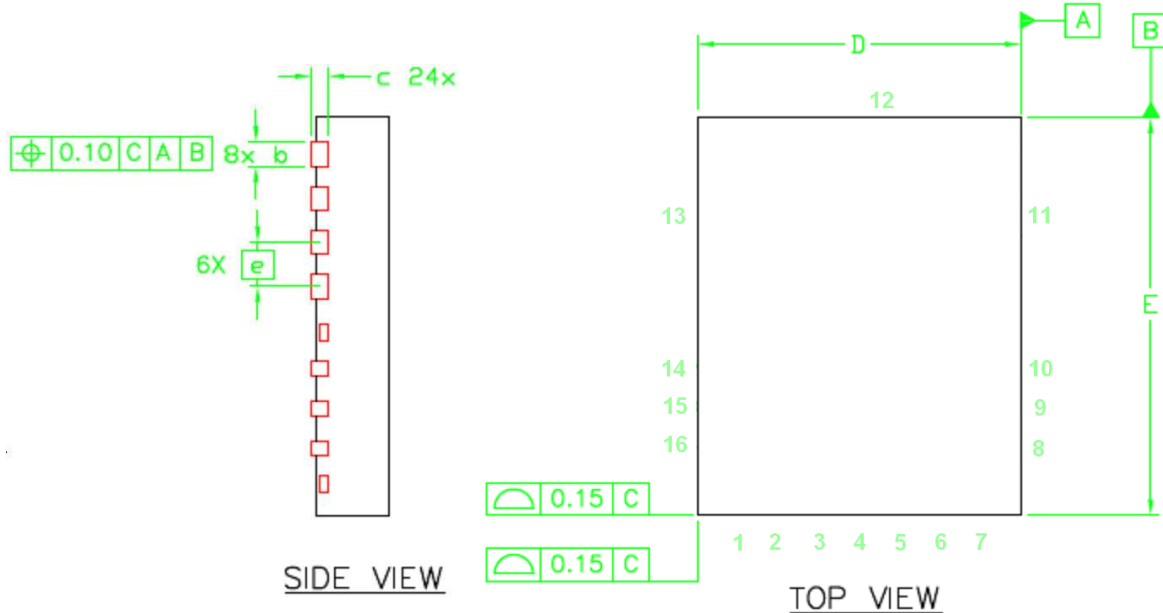
**Stencil Design**

The Stencil apertures for the lead lands should be approximately 80% of the area of the lead lads. Reducing the amount of solder deposited will minimize the occurrences of lead shorts. If too much solder is deposited on the center pad, the part will float and the lead lands will open.

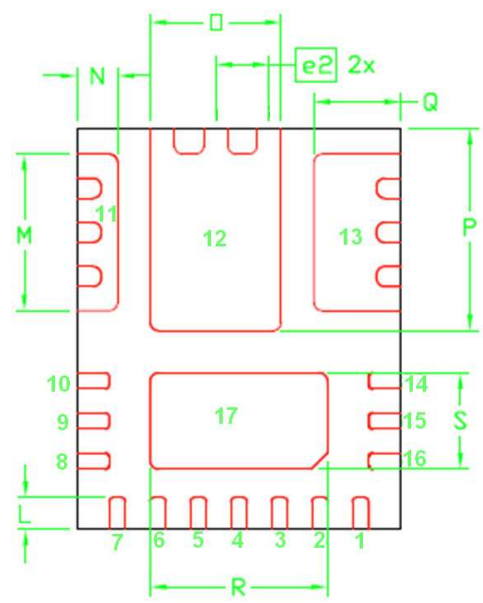
The maximum length and width of the land pad stencil aperture should be equal to the solder resist opening minus an annular 0.2mm pull back in order to decrease the risk of shorting the center land to the lead lands when the part is pushed into the solder paste.



Stencil Aperture  
 All Dimensions in mm



DIM	MILLIMETERS		INCHES	
	MIN	MAX	MIN	MAX
A	0.800	1.000	.0315	.0394
A1	0.000	0.050	.0000	.0020
b	0.250	0.350	.0098	.0138
b1	0.150	0.250	.0059	.0098
c	0.203 REF.		.0080 REF.	
D	4.000 BASIC		.1575 BASIC	
E	5.000 BASIC		.1969 BASIC	
e	0.550 BASIC		.0217 BASIC	
e1	0.500 BASIC		.0197 BASIC	
e2	0.659 BASIC		.0259 BASIC	
L	0.350	0.450	.0138	.0177
M	1.900	2.000	.0748	.0787
N	0.453	0.553	.0178	.0218
O	1.567	1.667	.0617	.0656
P	2.470	2.570	.0972	.1012
Q	1.024	1.124	.0403	.0443
R	2.138	2.238	.0842	.0881
S	1.150	1.250	.0453	.0492



**IR WORLD HEADQUARTERS:** 233 Kansas St., El Segundo, California 90245, USA Tel: (310) 252-7105  
TAC Fax: (310) 252-7903

Visit us at [www.irf.com](http://www.irf.com) for sales contact information  
Data and specifications subject to change without notice. 02/2011