

## Sensorless Motor Drive Platform for Appliance Based on iMOTION™ Chipset

### Features

- IRMCK171 - iMOTION™ digital control IC - based system
- MCE™ (Motion Control Engine) - high efficiency sinusoidal sensorless control of Permanent Magnet motors
- Supports both interior and surface permanent magnet motor sensorless control
- Single shunt current feedback reconstruction
- No external current or voltage sensing OP amp circuit required
- 230V/250W output power with IRAM336-025SB, iMOTION™ Integrated Power Module
- Bootstrap diode included in IRAM336-025SB
- Loss minimization Space Vector PWM
- Two-channel analog output (PWM)
- Embedded 8-bit high speed microcontroller (8051) for flexible I/O and man-machine interface
- Isolated JTAG programming port for emulation/debugger
- I<sup>2</sup>C serial interface
- MCE Designer™ tool for easy operation
- Flexible drive configuration
- RS232 interface
- Over-current fault protection
- Over-voltage / Under-voltage protection
- Zero Vector Braking control
- EMI Filter included

### Product Summary

Continuous output current	0.6 Arms*
Maximum output current	0.9 Apeak**
Maximum Internal clock	128 MHz
Sensorless control computation time	48 µsec max
MCE program RAM	12K bytes
Data RAM	2K bytes
Program OTP	20K bytes min
A/D input channels	5
A/D converter resolution	12 bits
A/D converter conversion speed	2 µsec
Analog output (D/A) resolution	8 bits
RS232C baud rate (typ.)	57.6K bps

\* Upgradeable to higher current with larger heat sink

\*\* Limited by current feedback gain resistor values.

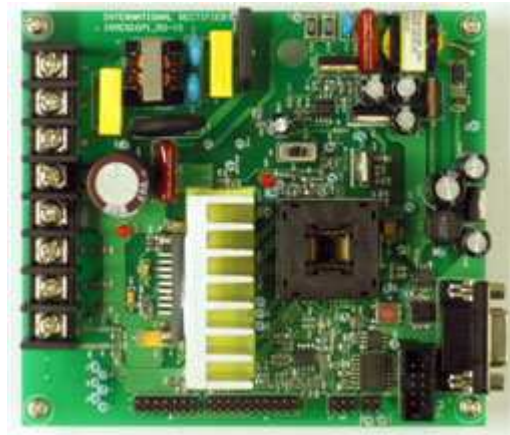

### Description

IRMCS1071 is a reference design for IRMCK171, which is a high performance motion control IC designed primarily for appliance applications. It's mainly aimed to achieve simple, low cost and high performance solutions for advanced appliance motor control. The system contains an integrated power module, IRAM336-025SB, which is also a part of iMOTION™ chipset. The user can readily evaluate high performance sensorless control with MCEDesigner™ software without spending development effort usually required in the traditional DSP or microcontroller based system. The complete B/Ms, schematics and layout are provided so that the user can adapt and tailor the design per application needs.



### Table of Contents

Overview ..... 3  
 Safety Precautions ..... 4  
 Debris When Unpacking ..... 6  
 Hardware Description ..... 7  
 PCB ..... 7  
 Isolation Boundary ..... 7  
 Power ..... 7  
 Crystal ..... 8  
 Reset Circuit ..... 8  
 EEPROM ..... 8  
 Digital I/O ..... 8  
 Analog Input ..... 8  
 Single Shunt Current Feedback ..... 8  
 Socket ..... 8  
 IRAM ..... 8  
 Power Supply ..... 8  
 EMI Filter ..... 8  
 DC Bus Capacitor ..... 8  
 System Installation and Operation ..... 9  
 Specifications ..... 10

### List of Figures

Figure 1 Typical Application Block Diagram Using IRMCK171 ..... 3  
 Figure 2 Top View of IRMCS1071 ..... 7

### List of Tables

Table 1 IRMCS1071 Electrical Specification ..... 10

## Overview

IRMCS1071 is a reference design platform for inverter-controlled appliance motor drive applications based on iMOTION™ chipset. It contains IRMCK171 digital motion control IC, and IRAM336-025SB, integrated power module.

IRMCK171 is International Rectifier's new integrated circuit device primarily designed as a one-chip solution for sensorless permanent magnet motor control in appliance applications. Unlike a traditional microcontroller or DSP, IRMCK171 provides a built-in closed loop sensorless control algorithm using a unique Motion Control Engine (MCE™) for surface/interior permanent magnet motors with sinusoidal back EMF. IRMCK171 also employs a unique single shunt current reconstruction circuit to eliminate additional analog/digital circuitry and enables a direct shunt resistor interface to the IC. The MCE™ consists of a collection of control elements, motion peripherals, a dedicated motion control sequencer and dual port RAM to map internal signal nodes. Motion control programming is achieved by using a dedicated graphical compiler integrated into the MATLAB/Simulink™ development environment. Sequencing, user interface, host communication, and upper layer control tasks can be implemented in the 8051 high-speed 8-bit microcontroller. The 8051 microcontroller is equipped with a JTAG port to facilitate emulation and debugging tools. Figure 1 shows a typical application schematic using the IRMCK171.

IRMCK171 has 32K bytes of program OTP and 12K of program RAM. At power up, 12K of the program stored in OTP is copied to RAM for high speed execution by the MCE processor. The 8051 program is executed directly from OTP by the 8051 processor. The IC on the reference board comes with preprogrammed OTP. Both 8051 application program and MCE firmware is ready for execution. IRMCK171 comes in a 48-pin QFP package.

IRAM336-025SB is an integrated power module developed and optimized for appliance motor control. Together with IRMCK171 it offers highly integrated solution for single shunt PM motor control. The module has several built-in protection features such as temperature feedback, shoot through prevention, under voltage lockout and shutdown. Furthermore, the module features a combination of highly efficient high voltage MOSFETs and the industry benchmark 3-phase HVIC driver. The bootstrapped power supplies for the high side drivers can be generated using internal bootstrap diodes eliminating the need for isolated power supplies.

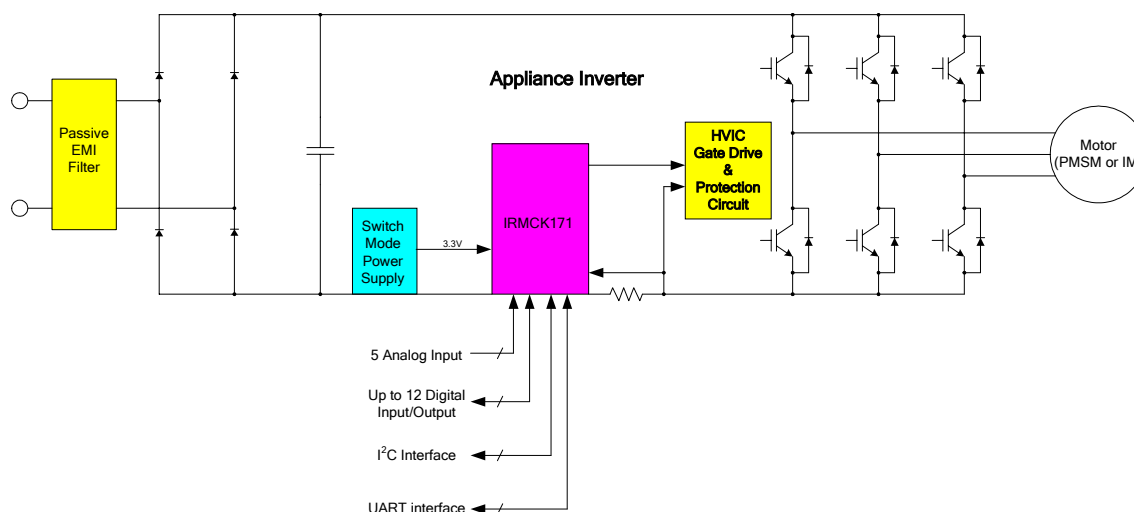

**Figure 1 Typical Application Block Diagram Using IRMCK171**

## Safety Precautions

In addition to the precautions listed throughout this manual, please read and understand the following statements regarding hazards associated with development system.



**ATTENTION:** The ground potential of the IRMCS1071 system is biased to a negative DC bus voltage potential. When measuring voltage waveform by oscilloscope, the scope ground needs to be isolated. Failure to do so may result in personal injury or death.  
Darkened display LEDs is not an indication that capacitors have discharged to safe voltage levels.



**ATTENTION:** IRMCS1071 system contains dc bus capacitors which take time to discharge after removal of main supply. Before working on drive system, wait three minutes for capacitors to discharge to safe voltage levels. Failure to do so may result in personal injury or death.  
Darkened display LEDs is not an indication that capacitors have discharged to safe voltage levels.

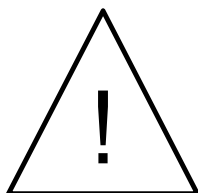

**ATTENTION:** Only personnel familiar with the drive and associated machinery should plan or implement the installation, start-up, and subsequent maintenance of the system. Failure to comply may result in personal injury and/or equipment damage.



**ATTENTION:** The surface temperatures of the drive may become hot, which may cause injury.

---



**ATTENTION:** IRMCS1071 system contains ESD (Electrostatic Discharge) sensitive parts and assemblies. Static control precautions are required when installing, testing, servicing or repairing this assembly. Component damage may result if ESD control procedures are not followed. If you are not familiar with static control procedures, reference applicable ESD protection handbook and guideline.

---



**ATTENTION:** An incorrectly applied or installed drive can result in component damage or reduction in product life. Wiring or application errors such as under sizing the motor, supplying an incorrect or inadequate AC supply, or excessive ambient temperatures may result in system malfunction.

---

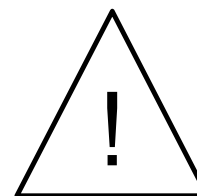

**ATTENTION:** Remove and lock out power from the drive before you disconnect or reconnect wires or perform service. Wait three minutes after removing power to discharge the bus voltage. Do not attempt to service the drive until bus voltage has discharged to zero. Failure to do so may result in bodily injury or death.

---

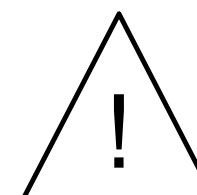

**ATTENTION:** Do not connect power factor correction capacitors to drive output terminals U, V, and W. Doing so may result in equipment damage or bodily injury.

---

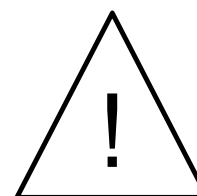

**ATTENTION:** IRMCS1071 system includes a field-weakening control function. However, if a drive trip occurs in field-weakening operation, excessive DC bus over-voltage will result. Users should take the necessary precautions to protect against DC bus over-voltage. Failure to do so may result in equipment damage or bodily injury.

---



## Debris When Unpacking

IRMCS1071 system is shipped with packing materials that need to be removed prior to installation.

---



**ATTENTION:** Failure to remove all debris and packing materials which are unnecessary for system installation may result in overheating or abnormal operating condition.

---

## Hardware Description

A top view of IRMCS1071 is shown in Figure 2.

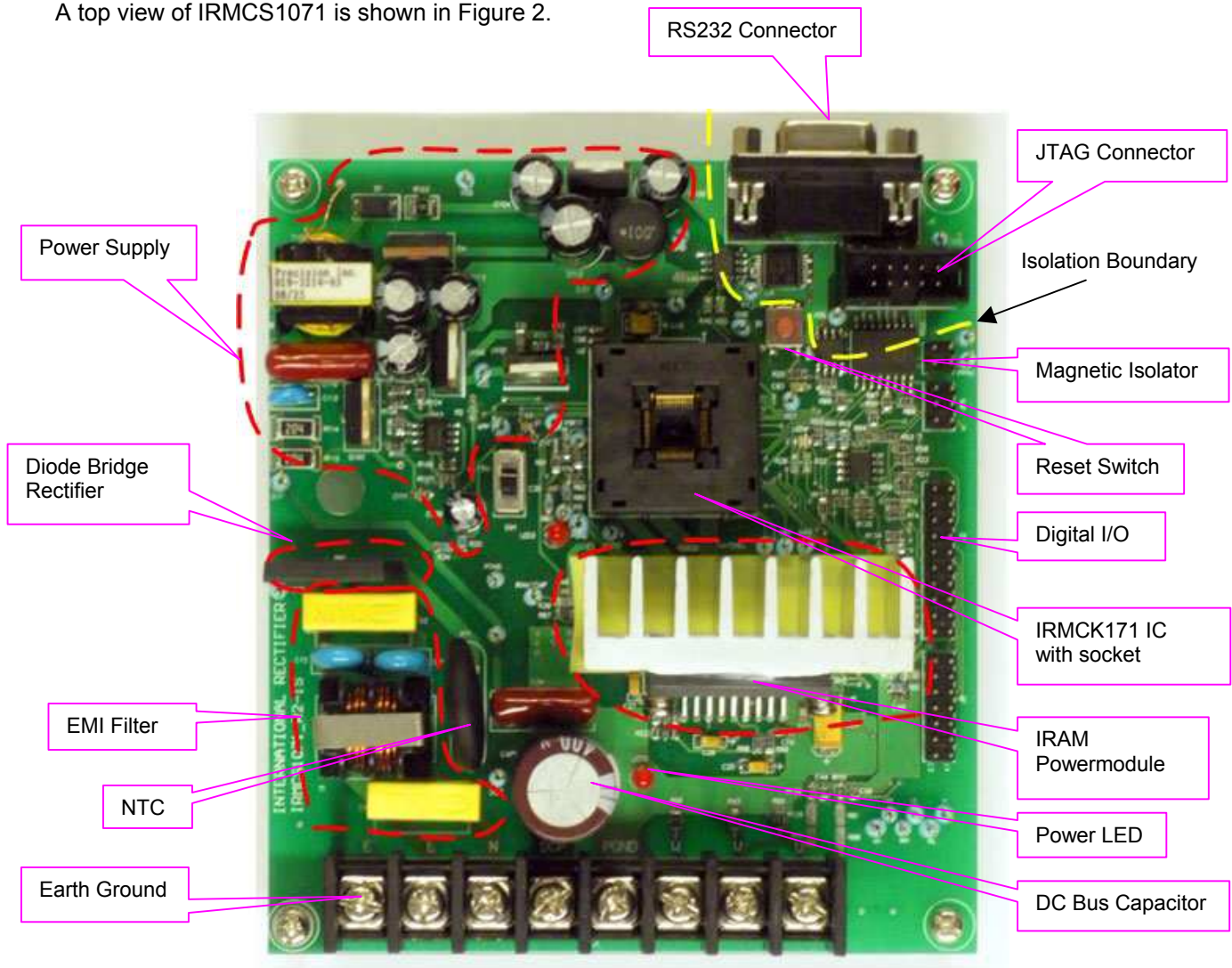

Figure 2 Top View of IRMCS1071

### PCB

The printed circuit board has two electrical layers and its size is 4.5 x 5 inches.

### Isolation Boundary

Note that there are two different grounds on this system. The RS232 connector and JTAG connector are isolated by magnetic isolators so that the user can connect their debugger and computer without isolating the computer. However, the user should keep in mind that most parts of the hardware have negative DC bus ground and it is necessary to isolate the scope when waveforms are measured.

### Power

IRMCK171 requires only a 3.3V power supply. Internally, the controller creates a 1.8V and a 1.2V required for the ADC.



## Crystal

A 4 MHz crystal is used to generate the system clock. Actual system frequency is adjustable by changing Phase Locked Loop configuration through Special Function Registers. For more information regarding the clock, please refer to the IRMCK171/IRMCK143 Reference Manual.

## Reset Circuit

IRMCK171 doesn't require external RC circuit for reset. The reset switch can be used to initialize the JTAG debugger. For more information regarding reset, please refer to the IRMCK171/IRMCK143 Reference Manual.

## EEPROM

The board is equipped by an EEPROM. With the provided setup the EEPROM is not used but it provides the user with the option of storing drive parameters etc.

## Digital I/O

Only some of the digital I/O's are used in IRMCS1071. However, all general purpose I/O's are connected to a header (J2). In addition, a number of test points have been added for easy debug of the system.

## Analog Input

Analog channels are connected to test points for ease of use.

## Single Shunt Current Feedback

IRMCK171 contains an high speed Operational Amplifier for single shunt current reconstruction. Resistors and capacitors for amplifier circuit are placed very close to the pins. Note that there is a separate trace from shunt resistor instead of sharing a plane with negative DC bus ground to get better current feedback.

## Socket

The control IC is mounted in a 48 pin socket to make replacement easy. If the user wishes to update the IC's software, e.g. when updating the 8051 program, replacement can be done without soldering.

## IRAM

IRAM336-025SB is mounted on a heat sink. Voltage across a 500 mΩ shunt is fed to 'Itrip' pin of IR2136 high voltage gate driver IC through low pass filter with 400 nsec time constant to initiate the over-current shutdown (Gatekill). For more information regarding IRAM, please refer to IRAM datasheet.

## Power Supply

Switch mode power supply operates at about 80 kHz and generates 15V(VCC), 3.3V and isolated 5V. 6.5V (VPP) is generated from 15V by a linear regulator.

## EMI Filter

Passive EMI filter on the board consists of two 0.1 μF X-caps and two 2.2 nF Y-caps and a 1 mH common mode inductor.

## DC Bus Capacitor

A 100 μF, 400 V, 85°C electrolytic capacitor is used to supply instantaneous power to the IRAM. IRMCS1071 does not have a dynamic braking unit. In case of field weakening operation, it is recommended to use an external regenerative unit or a braking unit for safety. GND and DCP can be used for connecting an external unit.





## **System Installation and Operation**

For information regarding hardware/software installation and operation, please refer to the IRMCS1071 Quick Start Guide.



## Specifications

T<sub>C</sub> = 25°C unless specified

Parameters	Values	Conditions
<b>Input Power</b>		
Voltage	115V-230Vrms, -20%, +10%	T <sub>A</sub> =40°C, RthSA=1.0 °C/W
Frequency	50/60 Hz	
Input current	2A rms @nominal output	
Input line impedance	4%~8% recommended	
<b>Output Power</b>		
Watts	200W continuous power	Vin=230V AC, f <sub>PWM</sub> =10kHz, f <sub>O</sub> =60Hz, T <sub>A</sub> =40°C, RthSA=1.0 °C/W, Vertically mounted to help air flow RthSA limits ΔTC to 10°C during overload
Current	0.6 ARMS nominal	
<b>Host interface (RS232C)</b>		
TXD, RXD	10V	Typical 57.6 Kbps, single ended
<b>JTAG interface</b>		
TMS, TDI, TCK, TDO	3.3V	Interface with FS2 debugger
<b>D/A</b>		
8- bit 2 Channel	0-3.3V output	8051 software needs modification to use it.
<b>A/D</b>		
12-bit	0 – 1.2V	DC bus, single shunt current, AIN1-AIN4
<b>DC bus voltage</b>		
Maximum DC bus voltage	400V	Should not exceed 400V more than 30 sec
Minimum DC bus voltage	120V	
<b>Current feedback</b>		
Current sensing device	Single shunt reconstruction	PCB design may reduce the resolution
Resolution	12-bit	
Latency	1 pwm cycle	
<b>Protection</b>		
Output current trip level	1.2A peak, typical	Detection from shunt on negative DC bus
Short circuit delay time	Maximum 5 μsec	line-to-line short, line-to-DC bus (-) short
Critical over voltage trip	380V	Re-scalable
Over voltage trip	360V	Re-scalable
Under voltage trip	120V	Re-scalable
<b>Power Device</b>		
IRAM336-025SB	6 MOSFET + IR2136 gate driver +3 bootstrap diode + NTC	
<b>System environment</b>		
Ambient temperature	0 to 40°C	95% RH max. (Non-condensing)

Table 1 IRMCS1071 Electrical Specification



International  
**IOR** Rectifier

IR WORLD HEADQUARTERS: 233 Kansas St., El Segundo, California 90245, Tel: (310) 252-7105  
<http://www.irf.com> *Data and specifications subject to change without notice.*

*Sales Offices, Agents and Distributors in Major Cities Throughout the World.*