

F

E

D

C

B

A

F

E

D

C

B

A

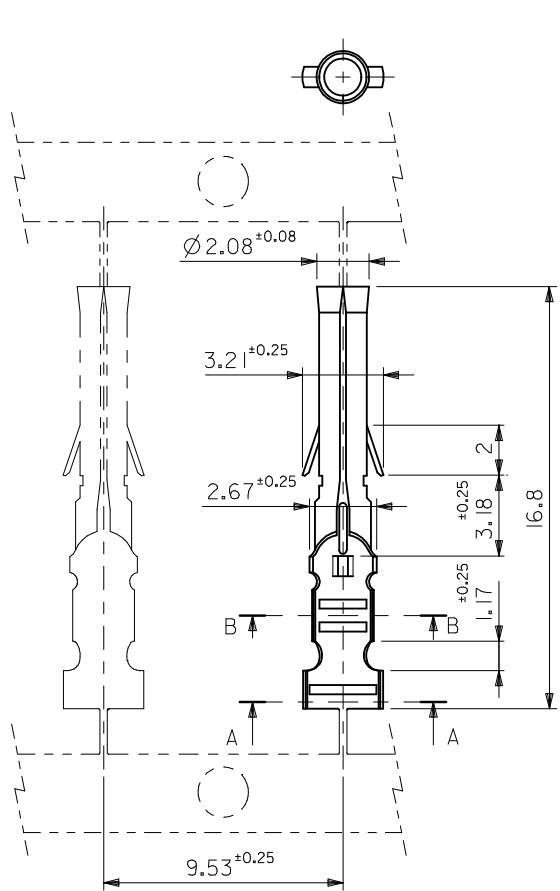

注記 NOTES:

1. 一般公差 : ±0.4  
GENERAL TOLERANCES : ±0.4

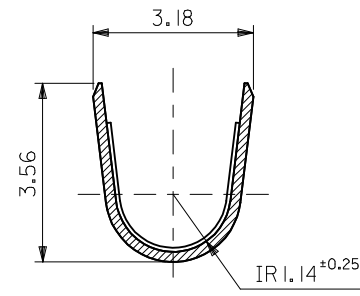
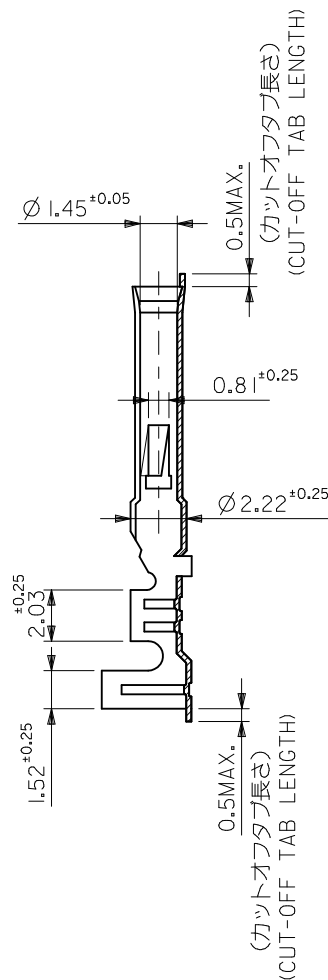

SECT. A-A  
(SCALE 10 : 1)

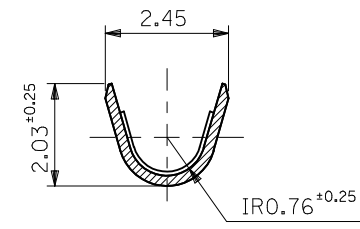

SECT. B-B  
(SCALE 10 : 1)

ニッケル (2 µm MIN.) 下地 金 (0.35 µm MIN.) GOLD (0.35 µm MIN.) OVER NICKEL (2 µm MIN.)	39-00-0334	I56 IGL	バラ端子 LOOSE
銅 (0.5 µm MIN.) 下地 錫 (0.9 µm MIN.) OVER COPPER (0.5 µm MIN.)	39-00-0333	I56 IG	連鎖状端子 CHAIN
	39-00-0331	I56 ITL	バラ端子 LOOSE
	39-00-0279	I56 IT	連鎖状端子 CHAIN
メッキ PLATING	EDP.NO.	ENG.NO.	形状 FORM

材料 MATERIAL 黄銅 BRASS 0.2 t
仕上げ FINISH
適用電線範囲 WIRE RANGE AWG# 18-#24
被覆外径 INS. RANGE Ø 1.5 ~ 3.1

REVISED
EC NO: J2009-19/41
DRWN: YA0YAGI 2009/02/16
CHKD: THARUYAMA 2009/02/17
APPR: NUKITA 2009/02/17
DESCRIPTION
REV

GENERAL TOLERANCES (UNLESS SPECIFIED)	
10 UNDER	± ---
10 OVER 30 UNDER	± ---
30 OVER	± ---
ANGULAR	± --- °
DRAFT WHERE APPLICABLE MUST REMAIN WITHIN DIMENSIONS	

DIMENSION STYLE MM ONLY	
DRAWN BY	DATE
H. HASEGAWA	'93/07/09
CHECKED BY	DATE
H. HIRAMOTO	'93/07/09
APPROVED BY	DATE
M. FUKUSHIMA	'93/07/09
MATERIAL NO.	
SEE TABLE	
SIZE	A3

SCALE 5:1	DESIGN UNITS METRIC	THIRD ANGLE PROJECTION
TITLE .062 DIA CRIMP FEMALE TERM		
MOLEX INCORPORATED		
DOCUMENT NO. SD-1561-001	SHEET NO. 1 OF 1	
THIS DRAWING CONTAINS INFORMATION THAT IS PROPRIETARY TO MOLEX INCORPORATED AND SHOULD NOT BE USED WITHOUT WRITTEN PERMISSION		