

PROJECT NO. SD-35407-002  
 SIMILAR ITEM  
 DO NOT SCALE DRAWING DIMENSION IN METRIC  
 DWG. NO. SD-35407-002

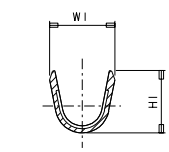

SECTION: C-C

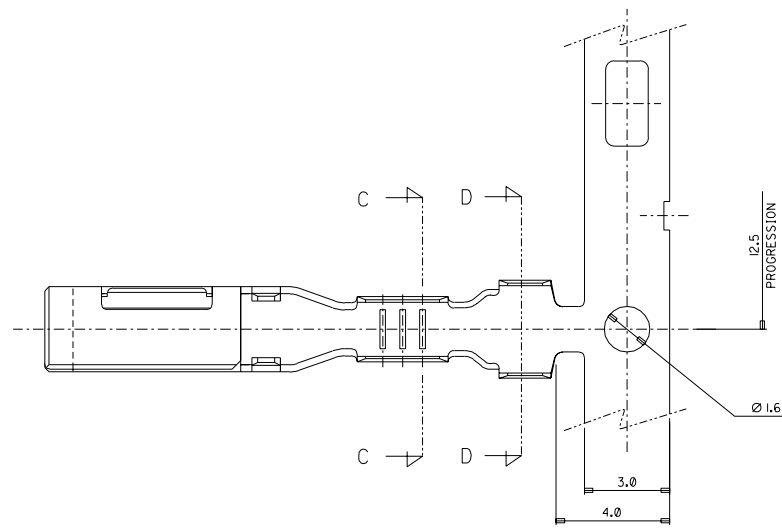
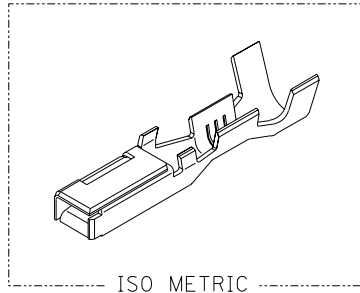
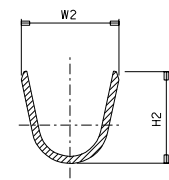
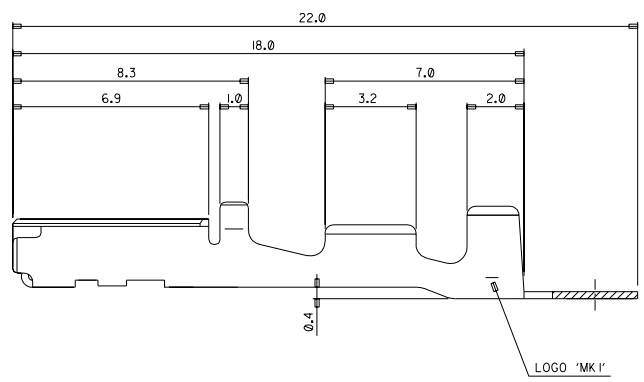

SECTION: D-D

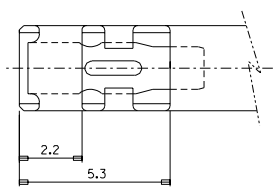
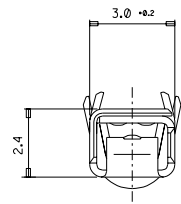

- NOTE**
1. MATERIAL: COPPER ALLOY, t=0.25.
  2. FINISH: PRE-TIN PLATE.
  3. RECOMMENDED LENGTH OF WIRE STRIP: 5.0-5.6.
  4. INSERTION-EXTRACTION FORCE WITH TAB TERMINAL P/N 35420.  
 INSERTION FORCE : 0.30±1.0 Kgf.  
 AFTER SIX TIMES OF INSERTION & EXTRACTION FORCE : 0.15±1.0 Kgf.

NO.	ENG-NO.	TYPE	PART NAME	CABLE SIZE (mm <sup>2</sup> )	DIMENSION			
					W1	H1	W2	H2
1	35407-6102	(S)	.090 FEMALE TER'L	AVSS(AVS) 0.3 - 0.5	2.5	2.4	3.4	3.5
2	35407-6202	(L)	.090 FEMALE TER'L	AVSS(AVS) 2.0	3.6	3.5	4.0	4.0
3	35407-6502	(M)	.090 FEMALE TER'L	AVSS(AVS) 0.85 - 1.25	2.6	3.0	4.0	4.0

CHANGED TENSION SPEC. EC NO. KGR2002-0090 DRAWN:MKIM 02/07/08 CHK'D:SIK/KIM 02/07/08 APPR:W.LEE	QUALITY SYMBOLS MAJOR CRITICAL	GENERAL TOLERANCES: (UNLESS SPECIFIED)	SCALE 8:1	DESIGN UNITS <input checked="" type="checkbox"/> mm <input type="checkbox"/> INCH	DIMENSIONS: <input type="checkbox"/> mm <input type="checkbox"/> INCH <input checked="" type="checkbox"/> mm ONLY	SHT	REV	
		4 PLACES ±0.1 3 PLACES ±0.1 2 PLACES ±0.1 1 PLACE ±0.25	DRAWN BY & DATE B.C.YOON '98.4.10	TITLE: .090 FEMALE TER'L (FT TYPE)	REVISION ON CAD ONLY			
REV	DESCRIPTION	APPROVED BY & DATE C.W.LEE '98.4.10	CAD FILENAME SD35407.DGN	MATERIAL NO. 354076102	DRAWING NO. SD-35407-002	SHEET NO. 1 OF 1	SIZE C	
DRAFT WHERE APPLICABLE MUST REMAIN WITHIN DIMENSIONS		THIS DRAWING CONTAINS INFORMATION THAT IS PROPRIETARY TO MOLEX INCORPORATED AND SHOULD NOT BE USED WITHOUT WRITTEN PERMISSION.					MX-A2	