

MATERIAL NO.	ENGINEERING NO.	DESCRIPTION	FINISH
197234100	19723-4100	CONTINUOUS STRIP WITH DIMPLE	UNPLATED
197234101	19723-4101	CONTINUOUS STRIP WITHOUT DIMPLE	
197234102	19723-4102	CONTINUOUS STRIP WITH DIMPLE	ELECTRO-TIN
197234103	19723-4103	CONTINUOUS STRIP WITHOUT DIMPLE	

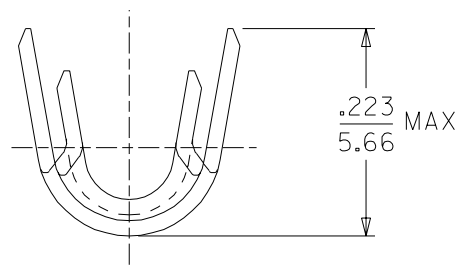

BACKGROUND OMITTED FOR CLARITY

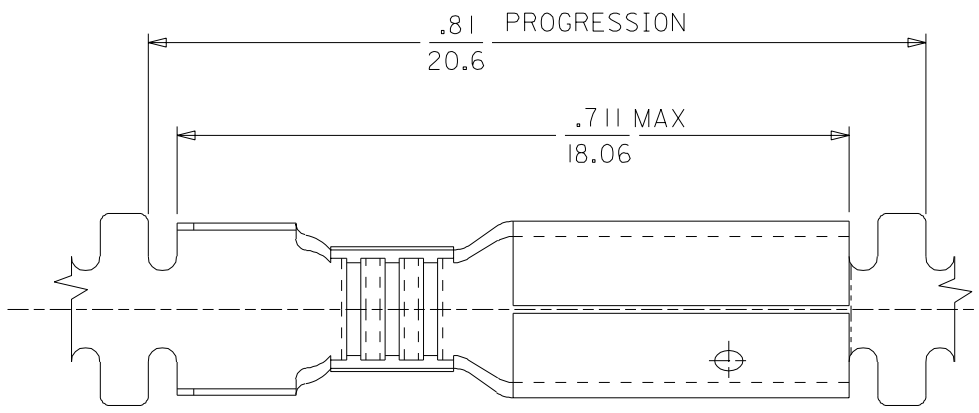
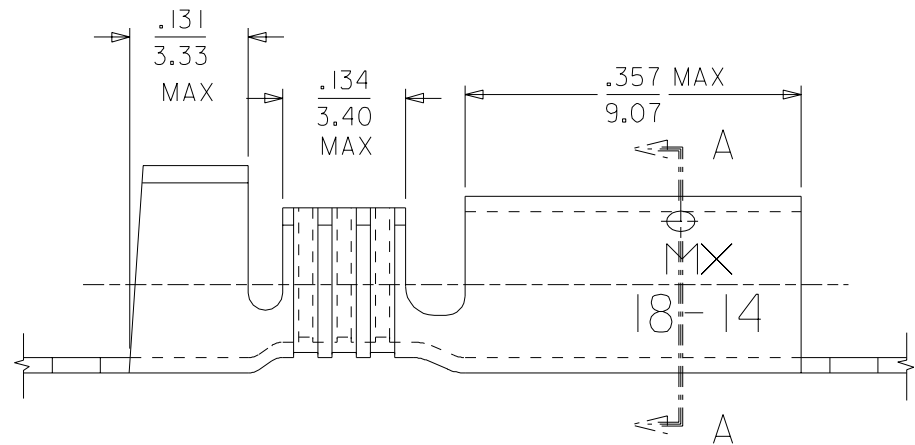

DIMPLE LOCATION OPTIONAL SEE CHART

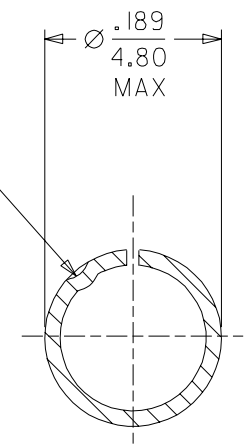

SECTION A-A  
BACKGROUND OMITTED FOR CLARITY

SALES DRAWING

NOTES:  
1. MATERIA: BRASS.  
2. PLATING: SEE CHART.

NEW RELEASE EC NO. ETC2004-0035 DRWN: BRE 03/08/08 CHK: HEB 03/08/08 APPR: RWD 03/08/08	QUALITY SYMBOLS	GENERAL TOLERANCES: (UNLESS SPECIFIED)		SCALE 4:1	DESIGN UNITS <input type="checkbox"/> mm <input checked="" type="checkbox"/> INCH	THIRD ANGLE PROJECTION <input checked="" type="checkbox"/> mm <input type="checkbox"/> INCH	DIMENSIONS: <input type="checkbox"/> mm <input checked="" type="checkbox"/> INCH <input type="checkbox"/> mm ONLY	SHT	REV
	MAJOR $\nabla = 0$	mm	INCH	DRAWN BY & DATE BRE 03/08/07		TITLE: SNAP PLUG RECEPTACLE .156 DIA VIBRAKRIMP 18-14 AWG CHAIN STAMPED			
	CRITICAL $\triangle = 0$	4 PLACES $\pm 0.$	$\pm .$	CHECKED BY & DATE HEB 03/08/07		MOLEX INCORPORATED			
		3 PLACES $\pm 0.$	$\pm .$	APPROVED BY & DATE RWD 03/08/07		CAD FILENAME SD-19723-002 .DWG	MATERIAL NO. SEE CHART	DRAWING NO. SD-19723-002	SHEET NO. 1 OF 1
	2 PLACES $\pm 0.$	$\pm .$	ANGULAR: $\pm 1/2^\circ$		THIS DRAWING CONTAINS INFORMATION THAT IS PROPRIETARY TO MOLEX INCORPORATED AND SHOULD NOT BE USED WITHOUT WRITTEN PERMISSION.				
	1 PLACE $\pm 0.$	$\pm .$	DRAFT WHERE APPLICABLE MUST REMAIN WITHIN DIMENSIONS		SIZE B				