

注記 NOTES:

1. 使用材料 MATERIAL
 ウエハー: 液晶ポリマー (LCP) ガラス充填 UL94V-0 (黒)
 WAFER: LIQUID CRYSTAL POLYMER (GLASS FILLED)
 UL94V-0 (COLOR: BLACK)
 ピン: 黄銅 (t=0.12)
 PIN: BRASS (t=0.12)
 金具: リン青銅 (t=0.2)
 FITTING NAIL: PHOSPHOR BRONZE (t=0.2)
2. メッキ仕様 PLATING
 ピン PIN
 金メッキ 0.2 マイクロメートル以上 (コンタクト部)
 GOLD 0.2MICROMETER MINIMUM (CONTACT AREA)
 金メッキ 0.4 マイクロメートル以下 (テール部)
 GOLD 0.4MICROMETER MAXIMUM (TAIL AREA)
 下地メッキ: ニッケルメッキ 1.5 マイクロメートル以上
 UNDER PLATING: NICKEL 1.5MICROMETER MINIMUM
 金具 FITTING NAIL
 錫メッキ 1.0 マイクロメートル以上
 TIN PLATING 1.0MICROMETER MINIMUM
 下地メッキ: ニッケルメッキ 1.0 マイクロメートル以上
 UNDER PLATING: NICKEL 1.0MICROMETER MINIMUM

3. (全極数/2) = 偶数の場合に適用。
 APPLY FOR (CIRCUIT/2)=EVEN.
4. 嵌合相手: 51338シリーズ
 MATE WITH: 51338 SERIES.
5. テール平坦度は、0.08以下
 テール及び金具の平坦度は、0.1以下
 TAIL COPLANARITY TO BE 0.08 MAXIMUM
 TAIL AND FITTING NAIL
 COPLANARITY TO BE 0.1 MAXIMUM
6. 本製品は 55909-***3 の鉛フリー品である。
 THIS PRODUCT IS LEAD FREE OF 55909-***3

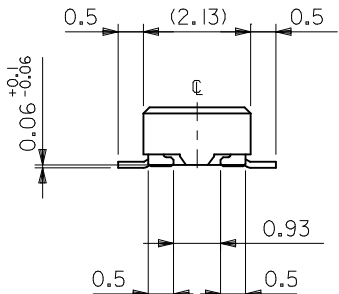
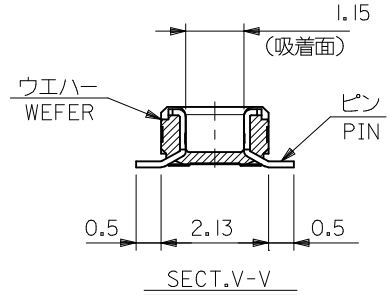

21.2	19.6	22.0	55909-1074	100
19.2	17.6	20.0	55909-0974	90
17.2	15.6	18.0	55909-0874	80
15.2	13.6	16.0	55909-0774	70
13.2	11.6	14.0	55909-0674	60
11.2	9.6	12.0	55909-0574	50
9.2	7.6	10.0	55909-0474	40
8.0	6.4	8.8	55909-3474	34
7.2	5.6	8.0	55909-0374	30
6.4	4.8	7.2	55909-2674	26
6.0	4.4	6.8	55909-2474	24
5.6	4.0	6.4	55909-2274	22
5.2	3.6	6.0	55909-0274	20
4.4	2.8	5.2	55909-1674	16
3.6	2.0	4.4	55909-9974	12
C	B	A	EMBOSSED TAPE PKG. ORDER No. オーダー番号	CKT.
CONNECTOR SERIES NO.			55909-***73	

REVISED EC NO: J2013-0254 DRW: KTOYODA 2012/08/30 CHK: D.TASAKAWA 2012/08/30 APPR: T.SAKAWA 2012/08/31	GENERAL TOLERANCES (UNLESS SPECIFIED)		DIMENSION STYLE MM ONLY		SCALE ---	DESIGN UNITS METRIC	THIRD ANGLE PROJECTION
	10 UNDER	±0.2	DRAWN BY HSHIMABUKURO	DATE 2004/02/20	TITLE 0.4 B-TO-B CONN. PLUG ASSY (HGT=1.5) WITH NAIL -LEAD FREE-		
	10 OVER 30 UNDER	±0.25	CHECKED BY K. TOJO	DATE 2004/02/20			
	30 OVER	±0.3	APPROVED BY M. SASAO	DATE 2004/02/20			
ANGULAR ±1/2 °	DRAFT WHERE APPLICABLE MUST REMAIN WITHIN DIMENSIONS		MATERIAL NO. SEE CHART		DOCUMENT NO. SD-55909-003	SHEET NO. 1 OF 2	
THIS DRAWING CONTAINS INFORMATION THAT IS PROPRIETARY TO MOLEX INCORPORATED AND SHOULD NOT BE USED WITHOUT WRITTEN PERMISSION							

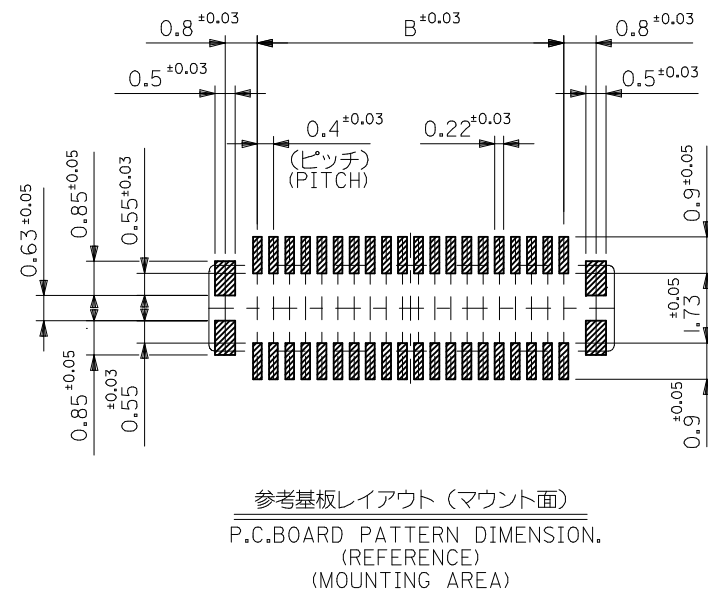
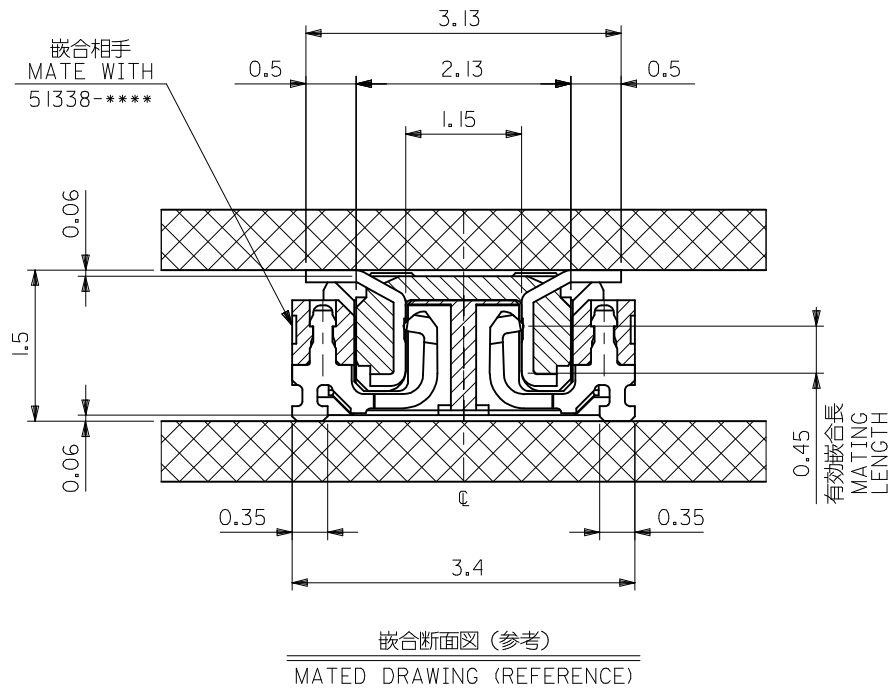

SEE SHEET 1 OF 2
EC NO.: J2013-0254
DRW: K. TOYODA 2012/08/30
CHKD: TASAKAWA 2012/08/30
APPR: TASAKAWA 2012/08/31

GENERAL TOLERANCES (UNLESS SPECIFIED)	
10 UNDER	±0.2
10 OVER 30 UNDER	±0.25
30 OVER	±0.3
ANGULAR	±3 °
DRAFT WHERE APPLICABLE MUST REMAIN WITHIN DIMENSIONS	

DIMENSION STYLE MM ONLY	
DRAWN BY	DATE
HSHIMABUKURO	2004/02/20
CHECKED BY	DATE
K. TOJO	2004/02/20
APPROVED BY	DATE
M. SASAO	2004/02/20
MATERIAL NO. SEE SHEET 1	
SIZE	A3

55909-**73	MODEL NO.
DESIGN UNITS METRIC	THIRD ANGLE PROJECTION
0.4 B-TO-B CONN. PLUG ASSY (HGT=1.5) WITH NAIL -LEAD FREE-	
molex	
DOCUMENT NO. SD-55909-003	SHEET NO. 2 OF 2
THIS DRAWING CONTAINS INFORMATION THAT IS PROPRIETARY TO MOLEX INCORPORATED AND SHOULD NOT BE USED WITHOUT WRITTEN PERMISSION	

NOTES

- 製品詳細寸法については製品単体図面を参照下さい。
RE DETAILED DIMENSION, SEE PRODUCT DRAWING.
- 梱包数量：2500個/リール
NUMBER OF CONNECTORS : 2500PCS/REEL
- リードテープ長さ LEAD TAPE LENGTH
20PCS. MIN. トップテープ接着部 (空エンボス)
TOP TAPE BONDED PART. (EMPTY)
部品挿入部
COMPONENT SUPPLIER
400 MIN.
末端部 (空部)
TAIL PART
40 MIN.
- 材料 MATERIAL
キャリアテープ (CARRIER TAPE) : ポリプロピレン (POLYPROPYLENE)
トップテープ (TOPTAPE) : PET , PE , PEF
リール (REEL) : ポリスチレン (PS) <リサイクル材を含む>
POLYSTYRENE (PS) <RECYCLE MATERIAL CONTAINED>
- ELV 及び RoHS 適合品。
ELV AND RoHS COMPLIANT.

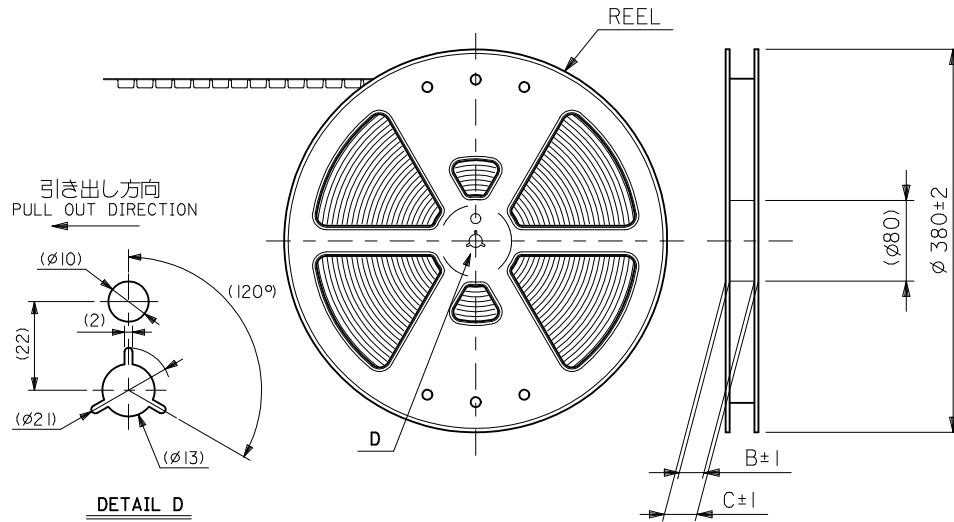

引き出し方向
PULL OUT DIRECTION

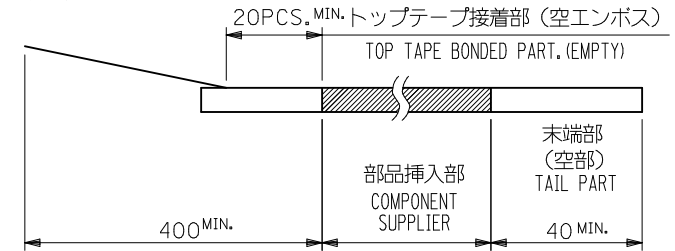

CONNECTOR SERIES No. 55909-**73

REVISED EC NO: J2010-2356 DRWN: TOSHIMA 2010/06/21 CHKD: KTOYODA 2010/07/20 APPR: MSASAO 2010/07/21	GENERAL TOLERANCES (UNLESS SPECIFIED)		DIMENSION STYLE MM ONLY	SCALE ---	DESIGN UNITS METRIC	THIRD ANGLE PROJECTION
	10 UNDER	±0.2	DRAWN BY H. SHIMAB	DATE 2004/02/20	TITLE 0.4 B-T-O-B CONN PLUG ASSY(HGT=1.5) EMBSTP PKG	
	10 OVER 30 UNDER	±0.25	CHECKED BY K. TOJO	DATE 2004/02/20	MOLEX INCORPORATED	
	30 OVER	±0.3	APPROVED BY M. SASAO	DATE 2004/02/20	MATERIAL NO. SEE CHART	DOCUMENT NO. SD-55909-004
J	DESCRIPTION ANGULAR ±3° DRAFT WHERE APPLICABLE MUST REMAIN WITHIN DIMENSIONS	SIZE A3	THIS DRAWING CONTAINS INFORMATION THAT IS PROPRIETARY TO MOLEX INCORPORATED AND SHOULD NOT BE USED WITHOUT WRITTEN PERMISSION			

引き出し方向
PULL OUT DIRECTION

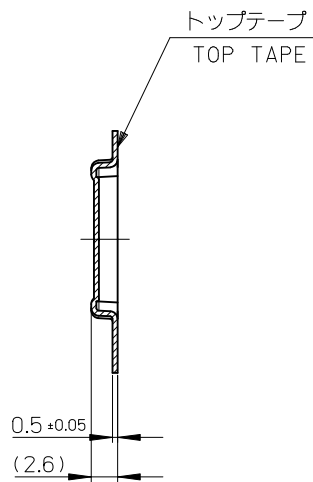

SECT. Y-Y

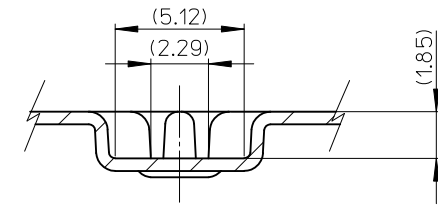
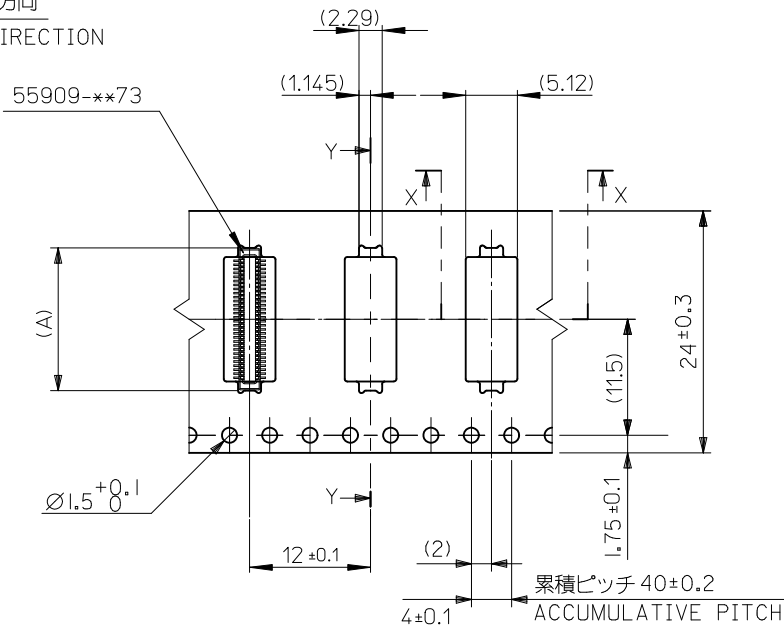

注記) 製品がポケット内に問題なく収まること。
NOTE. Pocket should contain product smoothly.

24	29.4	25.4	14.16	55909-0674	60	
			12.16	55909-0574	50	
			10.16	55909-0474	40	
			8.96	55909-3474	34	
			8.16	55909-0374	30	
			7.36	55909-2674	26	
			6.96	55909-2474	24	
			6.56	55909-2274	22	
			6.16	55909-0274	20	
キャリアテープ幅 CARRIER TAPE WIDTH		C	B	(A)	MATERIAL NO.	CKT

REVISED EC NO: J2010-2356 DRWN: TOSHIMA 2010/06/21 CHKD: KTOYODA 2010/07/20 APPR: MSASAO 2010/07/21	GENERAL TOLERANCES (UNLESS SPECIFIED)		DIMENSION STYLE MM ONLY		SCALE ---	DESIGN UNITS METRIC	CONNECTOR SERIES No. 55909-**73	
	10 UNDER	± 0.2	DRAWN BY H. SHIMAB	DATE 2004/02/20	TITLE 0.4 B-T0-B CONN PLUG ASSY(HGT=1.5) EMBSTP PKG			
	10 OVER 30 UNDER	± 0.25	CHECKED BY K. TOJO	DATE 2004/02/20	MATERIAL NO. DOCUMENT NO.			
	30 OVER	± 0.3	APPROVED BY M. SASAO	DATE 2004/02/20	SHEET NO. 2 OF 5			
	ANGULAR ± 3 °		SEE CHART		MOLEX INCORPORATED SD-55909-004			
DRAFT WHERE APPLICABLE MUST REMAIN WITHIN DIMENSIONS		THIS DRAWING CONTAINS INFORMATION THAT IS PROPRIETARY TO MOLEX INCORPORATED AND SHOULD NOT BE USED WITHOUT WRITTEN PERMISSION						

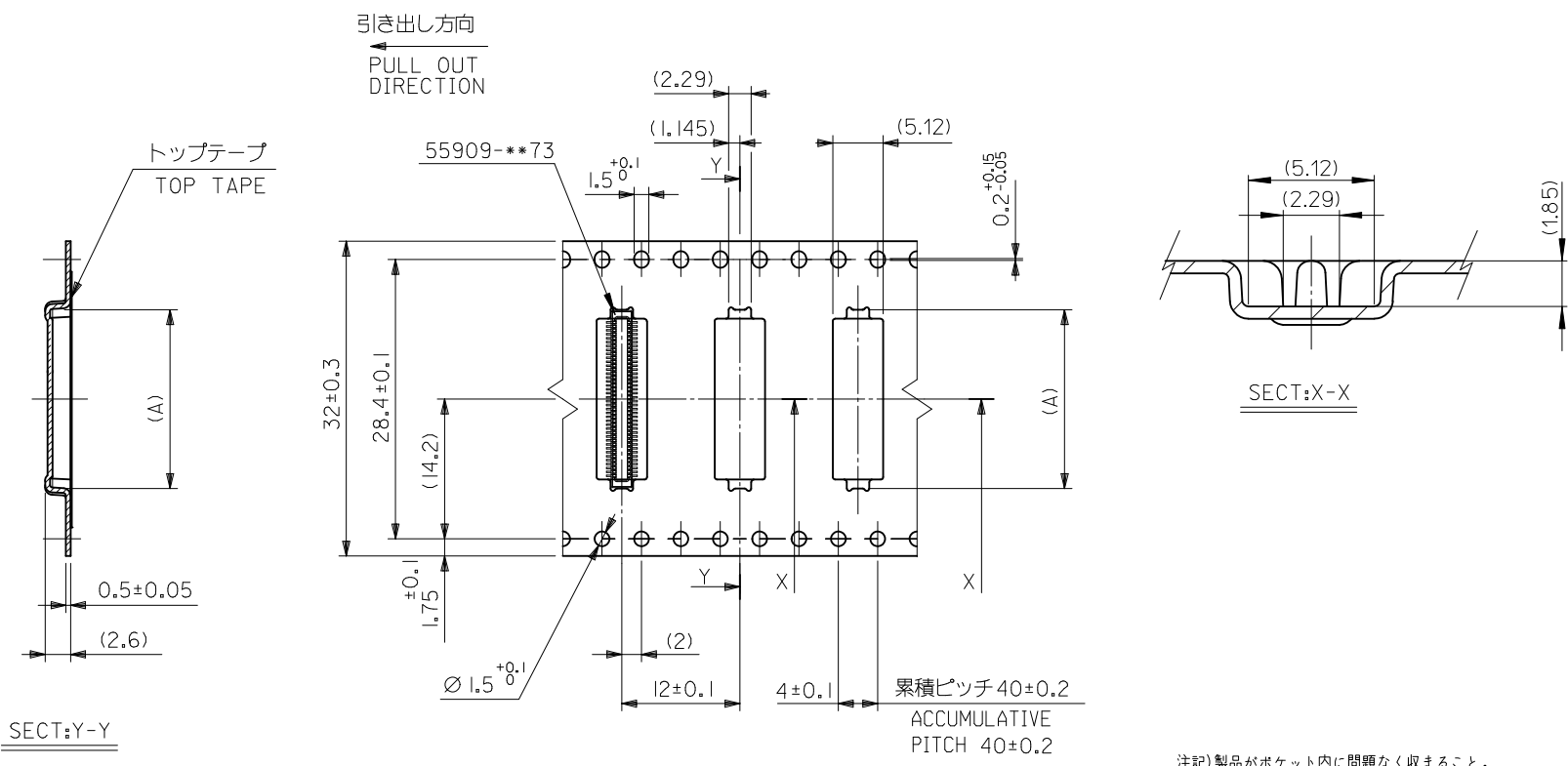

注記) 製品がポケット内に問題なく収まること。
NOTE: Pocket should contain product smoothly.

32mm幅キャリアテープ
32mm WIDTH CARRIER TAPE

32	37.4	33.4	19.16	55909-0974	90
			18.16	55909-0874	80
			16.16	55909-0774	70
キャリアテープ幅 CARRIER TAPE WIDTH	C	B	(A)	MATERIAL NO.	極数 CKT.

REVISED EC NO: J2010-2356 DRWN: TOSHIMA 2010/06/21 CHKD: KTOYODA 2010/07/20 APPR: MSASAO 2010/07/21	GENERAL TOLERANCES (UNLESS SPECIFIED)		DIMENSION STYLE MM ONLY		SCALE --- DESIGN UNITS METRIC		CONNECTOR SERIES No. 55909-**73 THIRD ANGLE PROJECTION	
	10 UNDER	±0.2	DRAWN BY	DATE	TITLE			
	10 OVER 30 UNDER	±0.25	H. SHIMAB	2004/02/20	0.4 B-T0-B CONN PLUG ASSY(HGT=1.5) EMBSTP PKG			
	30 OVER	±0.3	K. TOJO	2004/02/20	MOLEX INCORPORATED			
ANGULAR	±3 °	APPROVED BY	DATE	MATERIAL NO.		DOCUMENT NO.		SHEET NO.
DRAFT WHERE APPLICABLE MUST REMAIN WITHIN DIMENSIONS		M. SASAO	2004/02/20	SEE CHART		SD-55909-004		3 OF 5
		SIZE	THIS DRAWING CONTAINS INFORMATION THAT IS PROPRIETARY TO MOLEX INCORPORATED AND SHOULD NOT BE USED WITHOUT WRITTEN PERMISSION					
		A3						

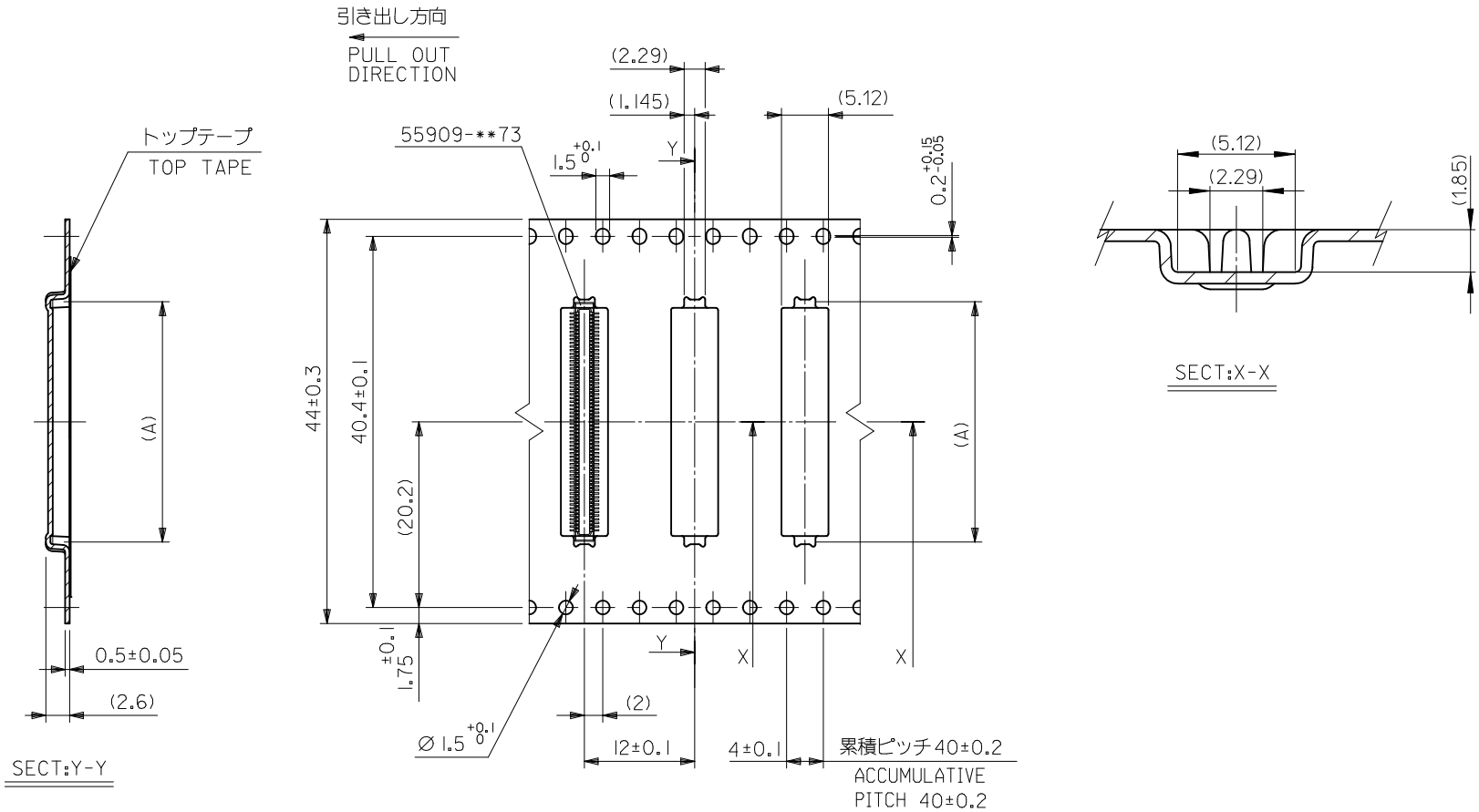

注記) 製品がポケット内に問題なく収まること。
NOTE. Pocket should contain product smoothly.

44mm幅キャリアテープ
44mm WIDTH CARRIER TAPE

44	49.4	45.4	22.16	55909-1074	100
キャリアテープ幅 CARRIER TAPE WIDTH	C	B	(A)	MATERIAL NO.	極数 CKT.

REVISED EC NO: J2010-2356 DRWN: TOSHIMA 2010/06/21 CHKD: KTOYODA 2010/07/20 APPR: MSASAO 2010/07/21	GENERAL TOLERANCES (UNLESS SPECIFIED)		DIMENSION STYLE MM ONLY		SCALE ---	DESIGN UNITS METRIC	CONNECTOR SERIES No. 55909-**73
	10 UNDER	±0.2	DRAWN BY H. SHIMAB	DATE 2004/02/20	TITLE 0.4 B-T0-B CONN PLUG ASSY(HGT=1.5) EMBSTP PKG		
	10 OVER 30 UNDER	±0.25	CHECKED BY K. TOJO	DATE 2004/02/20	APPROVED BY M. SASAO 2004/02/20		
	30 OVER	±0.3	APPROVED BY M. SASAO 2004/02/20		MATERIAL NO. DOCUMENT NO. SHEET NO.		
ANGULAR	±3 °	DRAFT WHERE APPLICABLE MUST REMAIN WITHIN DIMENSIONS		SEE CHART		MOLEX INCORPORATED SD-55909-004	
J	REV	THIS DRAWING CONTAINS INFORMATION THAT IS PROPRIETARY TO MOLEX INCORPORATED AND SHOULD NOT BE USED WITHOUT WRITTEN PERMISSION		4 OF 5			

引き出し方向
PULL OUT DIRECTION

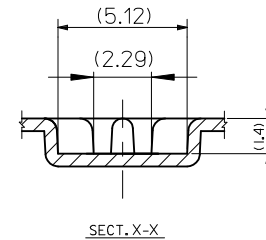
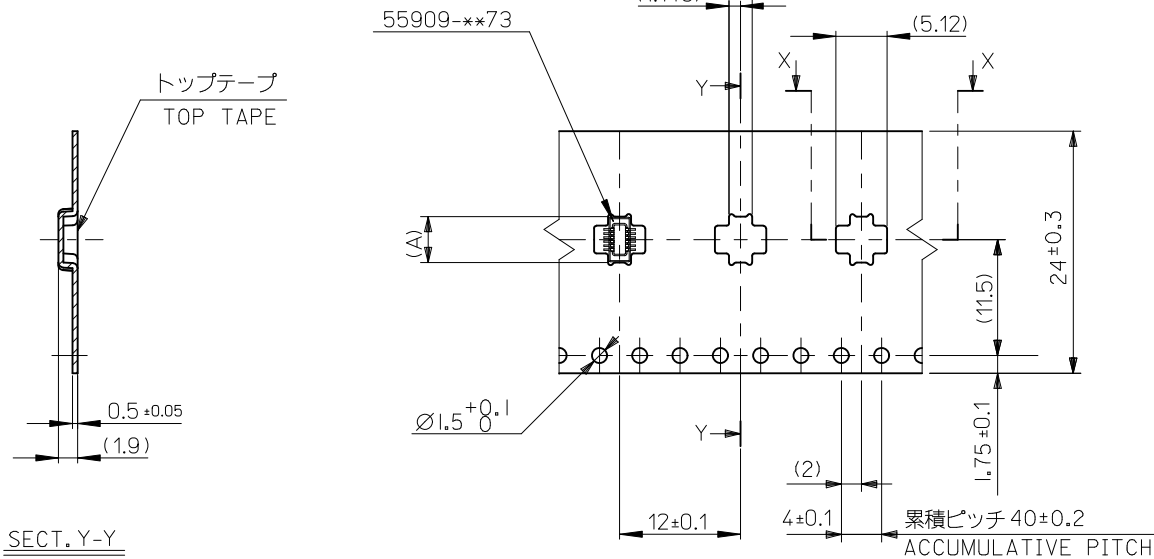

注記) 製品がポケット内に問題なく収まること。
NOTE. Pocket should contain product smoothly.

24	29.4	25.4	5.36	55909-1674	16
			4.56	55909-9974	12
キャリアテープ幅 CARRIER TAPE WIDTH	C	B	(A)	MATERIAL NO.	CKT

CONNECTOR SERIES No. 55909-***73

REVISED EC NO: J2010-2356 DRWN: TOSHIMA 2010/06/21 CHKD: KTOYODA 2010/07/20 APPR: MSASAO 2010/07/21	GENERAL TOLERANCES (UNLESS SPECIFIED)		DIMENSION STYLE	SCALE	DESIGN UNITS	THIRD ANGLE PROJECTION
	10 UNDER	±0.2	MM ONLY	---	METRIC	
	10 OVER 30 UNDER	±0.25	DRAWN BY	DATE	TITLE	
	30 OVER	±0.3	H. SHIMAB	2004/02/20	0.4 B-T-O-B CONN PLUG ASSY(HGT=1.5) EMBSTP PKG	
ANGULAR	±3°	CHECKED BY	DATE	MOLEX INCORPORATED		
DRAFT WHERE APPLICABLE MUST REMAIN WITHIN DIMENSIONS		M. SASAO	2004/02/20	DOCUMENT NO.		SHEET NO.
J	REV	SEE CHART		SD-55909-004		5 OF 5
		SIZE	THIS DRAWING CONTAINS INFORMATION THAT IS PROPRIETARY TO MOLEX INCORPORATED AND SHOULD NOT BE USED WITHOUT WRITTEN PERMISSION			