

10 9 8 7 6 5 4 3 2 1

注記 NOTES

1. 嵌合相手: 53307,53309,53353,53364 シリーズ
MATES WITH : 53307,53309,53353,53364 SERIES
2. ハウジングの ϕ から隣接するターミナルの ϕ 迄の位置を示す。
SHOW POSITION FROM ϕ OF HOUSING TO ϕ OF ADJACENT TERMINALS.
3. 本製品は 52588-**10 の鉛フリー品である。
THIS PRODUCT IS LEAD FREE OF 52588-**10.
4. ELV及RoHS適合品。
ELV AND RoHS COMPLIANT.

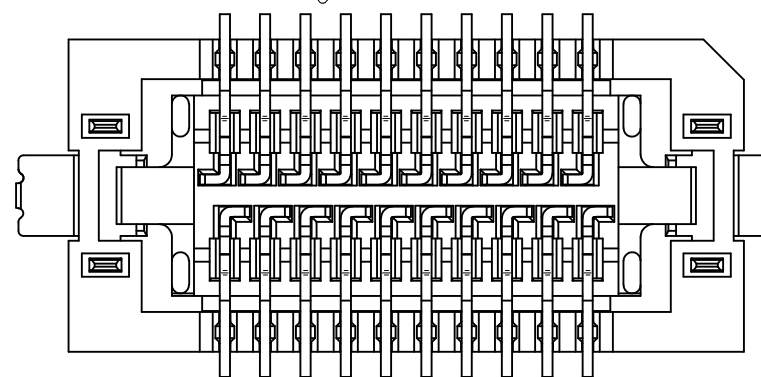
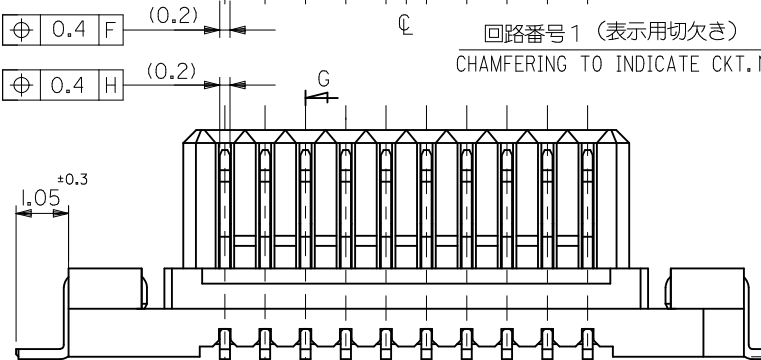
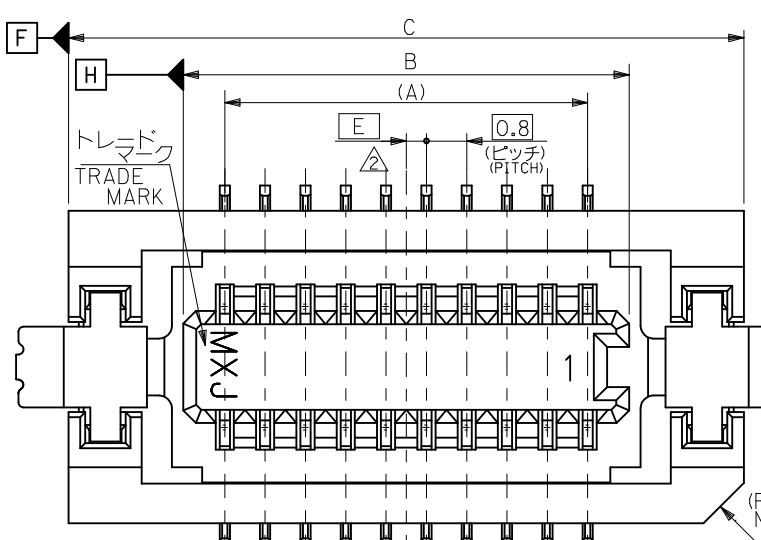

フィッティングネイル
FITTING NAIL
(リン青銅, 錫メッキ, ニッケル下地 t=0.2)
(PHOS-BRO. TIN 1.0 MICROMETER MIN.
NICKEL(UNDER PLATING) 1.0 MICROMETER MIN.)

回路番号 1 (表示用切欠き)
CHAMFERING TO INDICATE CKT. NO.1

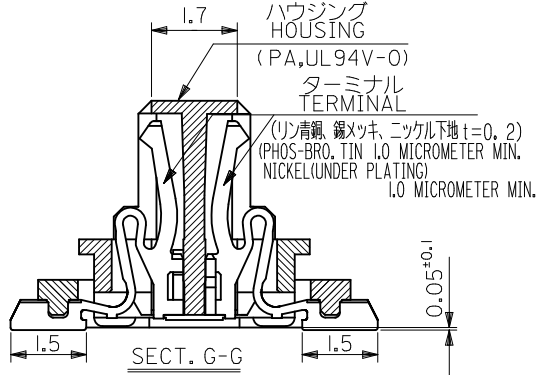
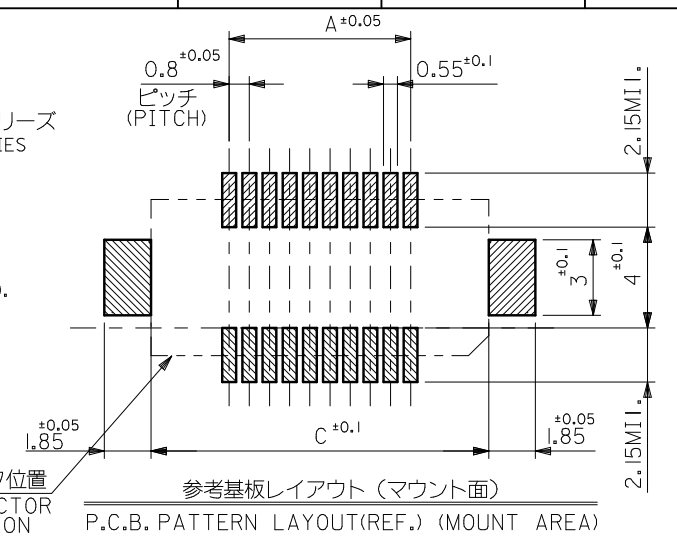
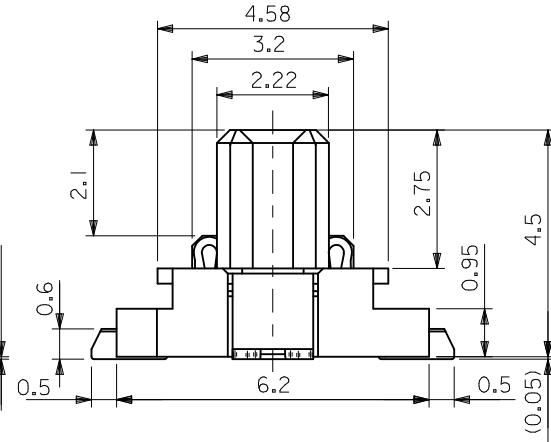

0.8	17.4	12.85	11.2	52588-3075	30
0.4	16.6	12.05	10.4	52588-2875	28
0.4	13.4	8.85	7.2	52588-2075	20
0.8	12.6	8.05	6.4	52588-1875	18
E	C	B	(A)	EMBOSSED PACKAGE	極数
				オーダー番号	ORDER NO. CKT.

REVISED EC NO: J2009-1949 DRW: NESATO 2010/01/13 CHKD: MATSUMOTO 2010/05/17 APPR: HIRATA 2010/05/17	GENERAL TOLERANCES (UNLESS SPECIFIED)		DIMENSION STYLE MM ONLY		SCALE ---	DESIGN UNITS METRIC	THIRD ANGLE PROJECTION
	10 UNDER	±0.20	DRAWN BY H. KAWABATA	DATE 2004/04/05	TITLE 0.8 FLOATING B/B CONN. HOUSING ASSY SMT. -LEAD FREE-		
	10 OVER 30 UNDER	±0.25	CHECKED BY K. TOJO	DATE 2004/04/05	MOLEX INCORPORATED		
	30 OVER	±0.30	APPROVED BY M. SASAO	DATE 2004/04/05	DOCUMENT NO. SD-52588-029		
ANGULAR ±3 °		DRAFT WHERE APPLICABLE MUST REMAIN WITHIN DIMENSIONS		MATERIAL NO. SEE TABLE		SHEET NO. 1 OF 1	
SIZE A3				THIS DRAWING CONTAINS INFORMATION THAT IS PROPRIETARY TO MOLEX INCORPORATED AND SHOULD NOT BE USED WITHOUT WRITTEN PERMISSION			

DIMENSIONS IN METRIC DO NOT SCALE DRAWING

NOTES

1. 梱包数量：1000個/リール NUMBER OF CONNECTORS:1000PCS/REEL

2. リードテープ長さ LEAD TAPE LENGTH

トップテープ TOP TAPE
リーダー部 LEADER PART トップテープ TOP TAPE
未接着部 NON-BONDED PART

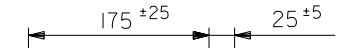

3. トップテープの剥離強度：(剥離方向は下図参照)

0.1~1.3N {10~130gf}

(但し、輸送時に剥離が発生しない事。)

PEELING OFF FORCE OF TOP TAPE

0.1~1.3N {10~130gf} (PEELING DIRECTION AS SHOWN IN FOLLOWING FIG.)

THIS REQUIREMENT SHOULD BE APPLIED AT SHIPMENT

PEEL OFF SHOULD NOT BE ALLOWED,

DURING TRANSPORTATION

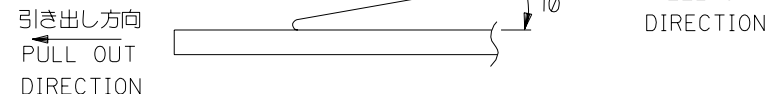

4. 材料

キャリアテープ：ポリプロピレン (PP) MATERIAL CARRIER TAPE:POLYPROPYLENE

トップテープ：PET, PE, PEF TOP TAPE:PET,PE,PEF

リール：ポリスチレン (PS) REEL:POLYSTYREN(PS)

<リサイクル材を含む> <RECYCLE MATERIAL CONTAINED>

5. 本製品は 52588-*90 の鉛フリー品である。
THIS PRODUCT IS LEAD FREE OF 52588-**90.

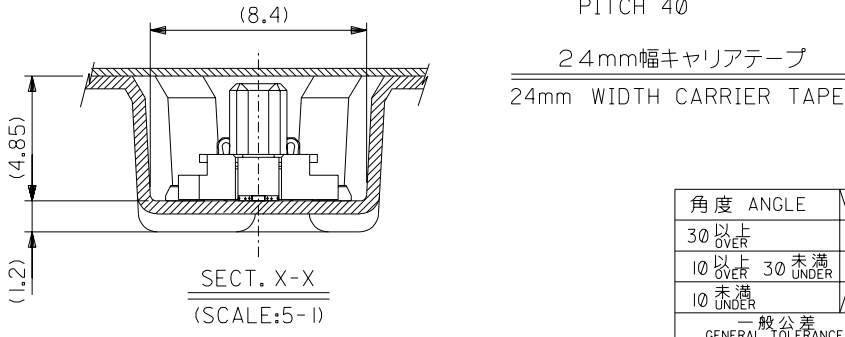
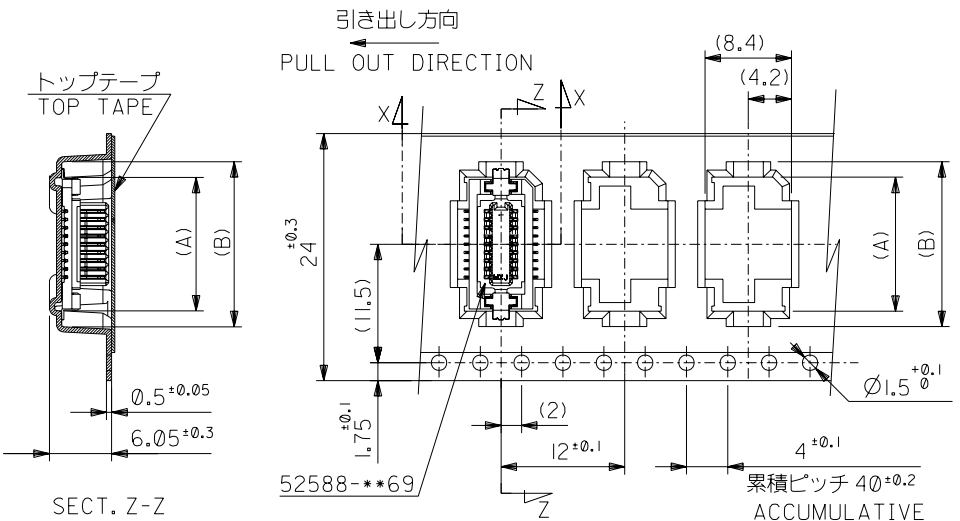
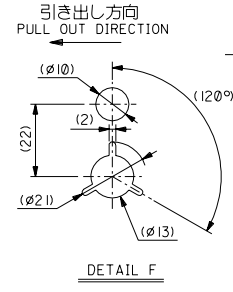
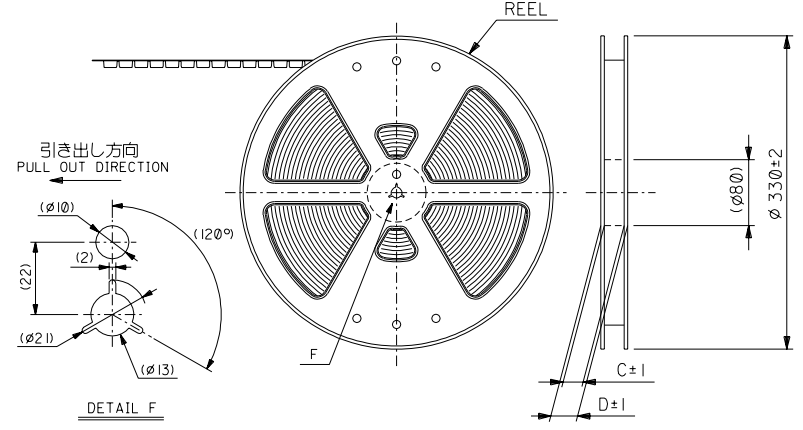

累積ピッチ 40 ±0.2
ACCUMULATIVE PITCH 40 ±0.2

角度 ANGLE	±3°
30以上 OVER	±0.5
10以上 30未満 UNDER	±0.25
10未満 UNDER	±0.2
一般公差 GENERAL TOLERANCES	

52588-**75	キャリアテープ幅	D	C	(B)	(A)	52588-2075	20
MODEL NO.	CARRIER TAPE WIDTH					52588-1875	18
						MATERIAL NO.	極数 CIRCUIT

材料 MATERIAL	注記参照 SEE NOTES	MOLEX	MOLEX-JAPAN CO.,LTD. 日本モレックス株式会社
仕上げ FINISH	—	REVISE ONLY ON CAD SYSTEM	
適用電線範囲 WIRE RANGE	—	TITLE 名称	
被覆外径 INS. RANGE	—	0.8 FLOATING B-To-B Hsg Assy SMT Embsp Pkg	
		-LEAD FREE-	
DRAWN BY '04/04/05 H.KAWABATA	CHK'D BY '04/04/05 K.TOJO	DWG. NO. (SHEET 1 OF 2) REV	
APP'D BY '04/04/05 M.SASAO	尺度 SCALE	SD-52588-030 0	

