

NOTES :

1. MATERIAL :
 HOUSING : LIQUID CRYSTAL POLYMER, GLASS FILLED,
 UL 94V-0, COLOUR : BLACK
 CONTACTS : COPPER ALLOY
 LATCHES : HIGH TEMPERATURE NYLON, UL 94V-0
 COLOUR : NATURAL (OFF-WHITE)

2. FINISH
 CONTACT AREA : 0.76 MICROMETER (30 MICROINCH) MIN GOLD OVER
 1.25 MICROMETER (50 MICROINCH) MIN NICKEL
 SMT TAIL : 2.54 MICROMETER (100 MICROINCH) MIN TIN OVER
 1.25 MICROMETER (50 MICROINCH) MIN NICKEL.
3. ACCEPTS 1.0 mm THICK MEMORY MODULE PER JEDEC MO-244
 FOR 244 CKTS AND MO-258 FOR 200 CKTS.
4. PRODUCT SPECIFICATION : PS-87782-027
5. PRODUCT SHALL BE PACKED IN TRAY. PLS REFER TO SHEET 5

6. DATE CODE SHALL BE MARKED LEGIBLY AS SHOWN : YYDD

7. PART NUMBER SHALL BE MARKED LEGIBLY AS SHOWN.
 87782-XXXX (REFER TO TABLE)

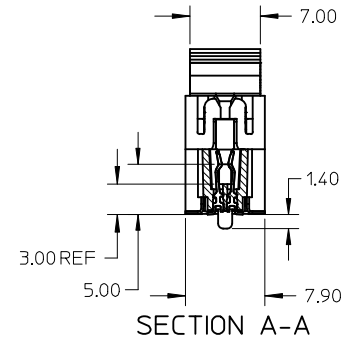
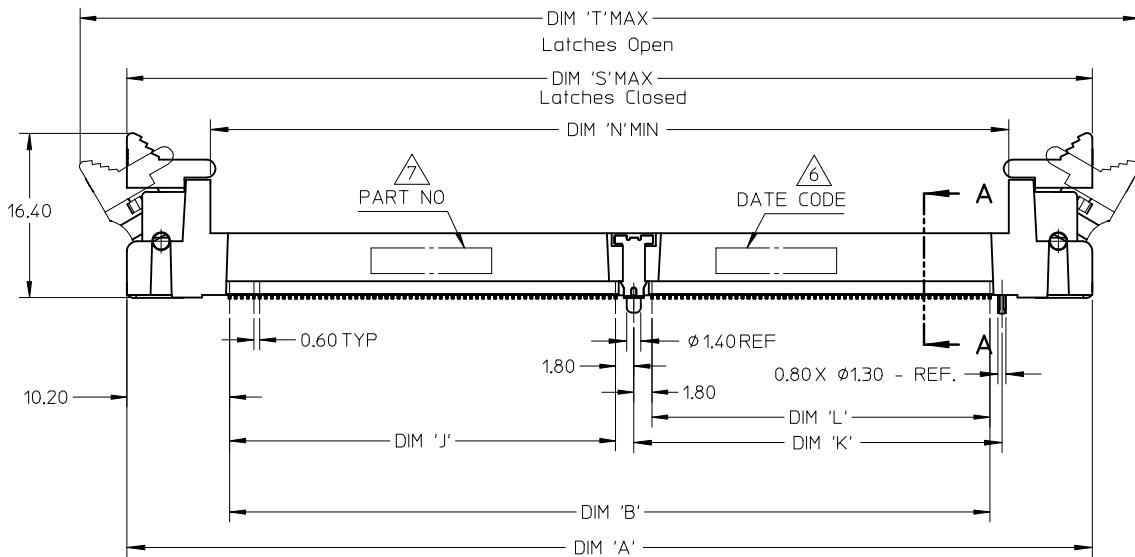
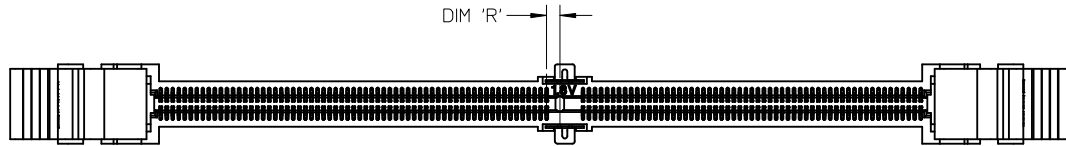

UPDATE DIMENSION EC NO: S2013-0123 DRW: EKS0H CHKD: CGTAN APPR: SILENI	2012/09/05 2012/09/12 2012/09/18	DESCRIPTION G3	QUALITY SYMBOLS	GENERAL TOLERANCES (UNLESS SPECIFIED)	DIMENSION STYLE	SCALE	DESIGN UNITS	THIRD ANGLE PROJECTION
			$\nabla = 0$ $\square = 0$	mm INCH 4 PLACES ± --- ± --- 3 PLACES ± --- ± --- 2 PLACES ± 0.13 ± --- 1 PLACE ± 0.25 ± --- ANGULAR ± 1 °	MM ONLY DRAWN BY: MLONG DATE: 2003/01/07 CHECKED BY: DATE: APPROVED BY: DATE: 2003/07/16 SKTOH DATE: 2003/07/17	NTS TITLE:	METRIC	MINI DIMM, 0.60MM PITCH 200/244 CKTS, VERTICAL
			DRAFT WHERE APPLICABLE MUST REMAIN WITHIN DIMENSIONS	SEE TABLE	Molex MOLEX INCORPORATED	SHEET NO. 1 OF 5		
			SIZE A3	THIS DRAWING CONTAINS INFORMATION THAT IS PROPRIETARY TO MOLEX INCORPORATED AND SHOULD NOT BE USED WITHOUT WRITTEN PERMISSION				

