

NOTES:

- MATERIAL:
 - OVER MOLD - POLYBUTYLENE TEREPHTHALATE (PBT), 94-V0.
 - GLASS FILLED 30%.
 - LATCH - STAINLESS STEEL ALLOY.
 - CABLE -
 - SIGNALS PVC INSULATION
 - SOLID COPPER SIGNAL AND DRAIN
 - INNER DIELECTRIC IS POLYOLEFIN
 - TWIN-AX SHIELD IS ALUMINIZED POLYESTER FOIL.
 - JACKET - PVC RED
 - PCB - FR4
- PRODUCT TO PERFORM PER
PRODUCT SPECIFICATION: PS-79536-001.
- PACKAGING: BULK PACK PER PK-79536-XXX.
- PRODUCT MATES TO 75783 (RIGHT ANGLE) AND 75784 (VERTICAL) SERIES.
- THIS PRODUCT CONFORMS TO THE MECHANICAL DIMENSIONING AND ELECTRICAL PERFORMANCE REQUIREMENTS OF SFF-8086 AND SFF-8087.
- MINIMUM RECOMMENDED RADIUS 28 MM.
- PRODUCT IS RoHS COMPLIANT.
- LENGTHS OVER 1 METER ARE NOT COMPLIANT WITH SAS 1.1 09E SPECIFICATION.
- LABEL INFO
MOLEX
<<PART NUMBER>>
MADE IN CHINA
WW/YY

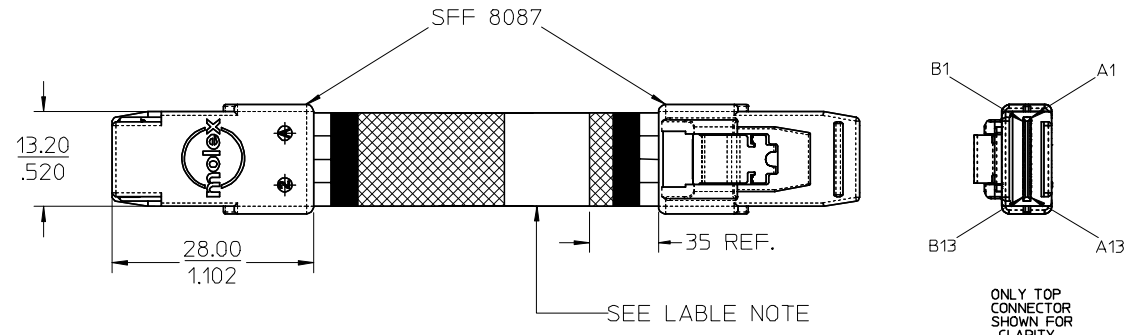
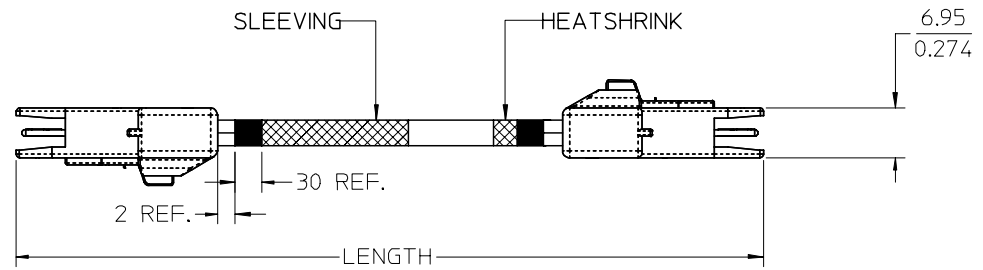

MATERIAL #	AWG	LENGTH(M)	TOL (+/-)
79575-2000	30	0.152	0.015
79575-2001	30	0.300	0.015
79575-2002	30	0.500	0.015
79575-2003	30	0.600	0.015
79575-2004	28	1.000	0.030
79575-2005	28	2.000	0.030

ENTER DESCRIPTION EC NO: USY2006-0236 TDRW:KPHILLIPS 2006/02/01 CHKD:T.HALL 2006/02/01 APPR:DDOYE 2006/02/07	QUALITY SYMBOLS ▽=0 ▽=0	GENERAL TOLERANCES (UNLESS SPECIFIED)		DIMENSION STYLE MM/IN		SCALE 1:1	DESIGN UNITS METRIC	THIRD ANGLE PROJECTION
		4 PLACES ± --- ± ---	DRAWN BY JERWIN	DATE 2005/10/27	TITLE IPASS (MINI-SAS) INTERNAL CABLE 26 CKT, 4X			
		3 PLACES ± --- ± .010	CHECKED BY THALL	DATE 2005/10/27	MOLEX INCORPORATED			
		2 PLACES ± 0.25 ± --- 1 PLACE ± --- ± --- ANGULAR ±1/2°	APPROVED BY DDOYE	DATE 2005/10/27	MATERIAL NO. SEE CHART	DOCUMENT NO. SD-79575-200	SHEET NO. 1 OF 2	
DRAFT WHERE APPLICABLE MUST REMAIN WITHIN DIMENSIONS			THIS DRAWING CONTAINS INFORMATION THAT IS PROPRIETARY TO MOLEX INCORPORATED AND SHOULD NOT BE USED WITHOUT WRITTEN PERMISSION					

IPASS™ IS A TRADEMARK OF MOLEX

6

5

4

3

2

1

D

C

B

A

D

C

B



A

GROUND	B13		A13	GROUND
TX3-	B12	▶	A12	RX3-
TX3+	B11	▶	A11	RX3+
GROUND	B10		A10	GROUND
TX2-	B9	▶	A9	RX2-
TX2+	B8	▶	A8	RX2+
GROUND	B7		A7	GROUND
TX1-	B6	▶	A6	RX1-
TX1+	B5	▶	A5	RX1+
GROUND	B4		A4	GROUND
TX0-	B3	▶	A3	RX0-
TX0+	B2	▶	A2	RX0+
GROUND	B1		A1	GROUND
GROUND	A13		B13	GROUND
RX3-	A12	◀	B12	TX3-
RX3+	A11	◀	B11	TX3+
GROUND	A10		B10	GROUND
RX2-	A9	◀	B9	TX2-
RX2+	A8	◀	B8	TX2+
GROUND	A7		B7	GROUND
RX1-	A6	◀	B6	TX1-
RX1+	A5	◀	B5	TX1+
GROUND	A4		B4	GROUND
RX0-	A3	◀	B3	TX0-
RX0+	A2	◀	B2	TX0+
GROUND	A1		B1	GROUND

NOTE:

- PIN OUT CONFORMS TO SAS 1.1 9.0D SECTION 5.2.4.1.2.3
- ALL SIGNAL GROUNDS ARE BUSSED IN PCB. PINS A1, A13, B1, & B13 DO NOT HAVE CORRESPONDING SOLDER PADS.

IPASS™ IS A TRADEMARK OF MOLEX

INITIAL RELEASE EC NO: USY2006-0236 DRWN:KPHILLIPS 2006/02/01 CHKD:T.HALL 2006/02/01 APPR:DDOYE 2006/02/07	QUALITY SYMBOLS  =0  =0	GENERAL TOLERANCES (UNLESS SPECIFIED)		DIMENSION STYLE MM/IN		SCALE 1:1	DESIGN UNITS METRIC	 THIRD ANGLE PROJECTION		
			mm	INCH	DRAWN BY JERWIN	DATE 2005/10/27	TITLE IPASS™ (MINI-SAS) INTERNAL CABLE 26 CKT, 4X			
		4 PLACES	± ---	± ---	CHECKED BY THALL	DATE 2005/10/27				
		3 PLACES	± ---	± .010	APPROVED BY DDOYE		DATE 2005/10/27	MOLEX INCORPORATED DOCUMENT NO. SD-79575-200		
2 PLACES	± 0.25	± ---	MATERIAL NO. SEE CHART		SHEET NO. 2 OF 2					
1 PLACE	± ---	± ---	ANGULAR ±1/2°		THIS DRAWING CONTAINS INFORMATION THAT IS PROPRIETARY TO MOLEX INCORPORATED AND SHOULD NOT BE USED WITHOUT WRITTEN PERMISSION					
DRAFT WHERE APPLICABLE MUST REMAIN WITHIN DIMENSIONS										

5

4

3

2

1