

NOTES

1. MATERIAL:
 - CAGE: NICKEL SILVER, THICKNESS: 0.25mm
 - CONNECTOR HOUSING: GLASS FILLED LIQUID CRYSTAL POLYMER (LCP), UL 94V-0, COLOR: BLACK
 - OVERMOLD TERMINAL HOUSING: GLASS FILLED LIQUID CRYSTAL POLYMER (LCP), UL 94V-0, COLOR: BLACK
 - TERMINALS: TIN BRASS
 - EMI GASKET: CONDUCTIVE ELASTOMER
 - LIGHTPIPE HOUSING: ZINC
 - LIGHTPIPES: POLYCARBONATE, COLOR: CLEAR
2. FINISHES:
 - TERMINALS: CONTACT AREA: 0.76 MICROMETERS MINIMUM HARD GOLD OVER 1.27 MICROMETERS MINIMUM NICKEL.
 - COMPLIANT TAIL - MATTE TIN/LEAD OPTION: 0.76 TO 152 MICROMETERS 90/10 MATTE TIN-LEAD OVER 0.76 MICROMETERS MINIMUM NICKEL.
 - COMPLIANT TAIL - MATTE TIN OPTION: 0.76 TO 1.52 MICROMETERS MATTE TIN OVER 0.76 MICROMETERS MINIMUM NICKEL.
 - LIGHTPIPE HOUSING: 80 MICROMETERS MINIMUM NICKEL OVER COPPER
3. REFER TO PS-75310-001 PRODUCT SPEC FOR ALL ELECTRICAL, MECHANICAL AND ENVIRONMENTAL SPECIFICATIONS.
4. LIGHTPIPE PAD LAYOUT IS FOR 0805 LOW-PROFILE LED PACKAGE, FOR OTHER RECOMMENDED LAYOUTS REFER TO MOLEX'S REPORT TS-75310-001.
5. REFER TO PK-76352-001 FOR ALL PACKAGING SPECIFICATIONS.
6. THE SURFACES CONFORM TO THE MOLEX COSMETIC SPEC PS-45499-002. ALL EXTERIOR SURFACES TO BE CLASS "B" SURFACE EXCEPT THE UNDERSIDE (CLASS "C") OF THE CAGE (SIDE TOWARD THE PCB) AND AS OTHERWISE NOTED.
7. THE OVERALL CAGE WIDTH AT THE VERTICAL CENTER OF THE FRONT EDGE WILL FALL WITHIN THIS DIMENSION: 114.80+/-0.30 MM. THIS PORTION OF THE CAGE WILL FLEX INWARD AS THE CAGE IS BEING INSERTED INTO THE BEZEL OPENING.
8. REFER TO AS-76090-001 FOR HIGH SPEED ROUTING RECOMMENDATIONS.
9. DATE CODE LOCATION IS SHOWN ABOVE.
 DATE CODE FORMAT: DDDY MX A1
 DDD = DAY OF THE YEAR
 Y = YEAR
 MX = MOLEX
 A = ALPHA CHARACTER - INDICATES MANUFACTURING LINE
 1 = NUMERIC CHARACTER - INDICATES PRODUCTION SHIFT

PART NUMBER	LIGHT PIPE CONFIGURATION SEE SHEET 2	COMPLIANT TAIL PLATING
1700176001	4 LIGHT PORTS	MATTE TIN / LEAD
1700176002	INNER 2 PORTS	MATTE TIN / LEAD
1700176003	OUTER 2 PORTS	MATTE TIN / LEAD
1700177001	4 LIGHT PORTS	MATTE TIN
1700177002	INNER 2 PORTS	MATTE TIN
1700177003	OUTER 2 PORTS	MATTE TIN
1700177004	4 LIGHT PORTS - SPECIAL CONFIGURATION	MATTE TIN

ADD -7004 ASSMBLY EC NO: UCP2015-0336 DR:WINBARKER 2014/10/08 CHKD:TIBARRA 2014/12/04 APPR:SMILLER 2014/12/16	QUALITY SYMBOLS	GENERAL TOLERANCES (UNLESS SPECIFIED)	DIMENSION STYLE MM ONLY	SCALE 2:1	DESIGN UNITS METRIC	THIRD ANGLE PROJECTION
	▽=0	mm INCH	DRAWN BY DATE JJANTELEZIO 2009/11/03	STACKED SFP+ 2X8 ASSY WITH ELASTOMERIC GASKET LIGHTPIPES- IMPROVED EMI MOLEX INCORPORATED		
	▽=0	4 PLACES ± --- ± ---	CHECKED BY DATE JKACHLIC 2009/11/03			
	▽=0	3 PLACES ± --- ± ---	2 PLACES ± 0.13 ± ---	APPROVED BY DATE	MATERIAL NO. SEE TABLE	DOCUMENT NO. SD-170017-002
		1 PLACE ± 0.25 ± ---		DRAFT WHERE APPLICABLE MUST REMAIN WITHIN DIMENSIONS THIS DRAWING CONTAINS INFORMATION THAT IS PROPRIETARY TO MOLEX INCORPORATED AND SHOULD NOT BE USED WITHOUT WRITTEN PERMISSION		

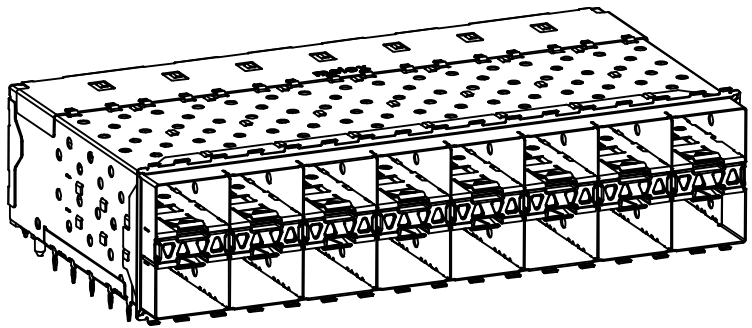

1700176001 AND 1700177001
WITH INNER & OUTER LIGHTPIPE PORTS

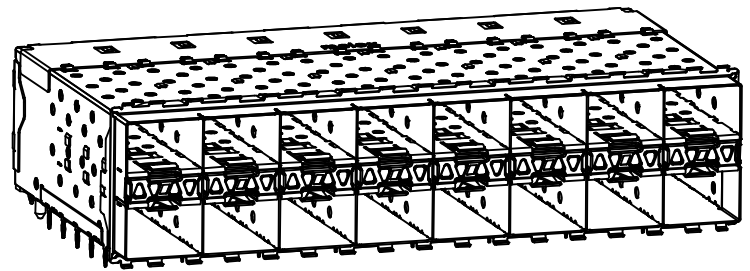

1700177004
WITH INNER & OUTER LIGHTPIPE PORTS
SPECIAL CONFIGURATION

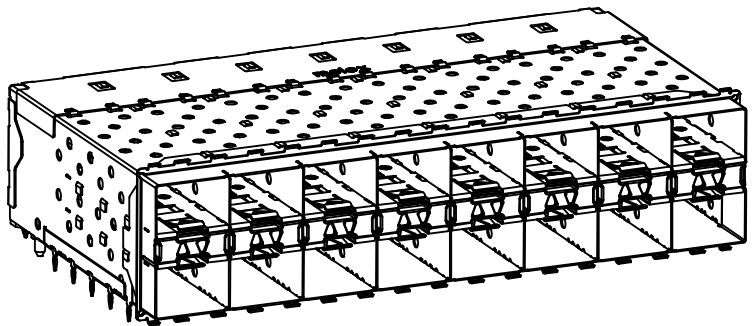

1700176002 AND 1700177002
WITH INNER LIGHTPIPE PORTS

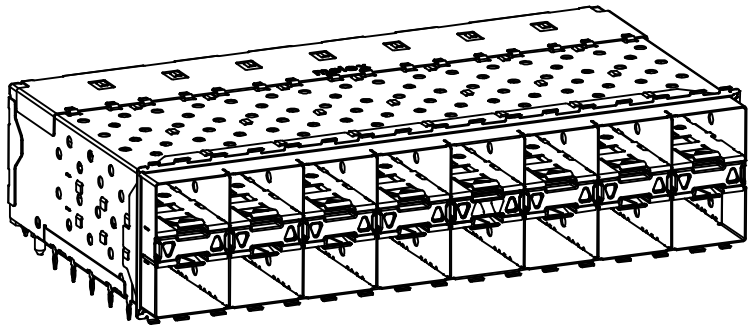

1700176003 AND 1700177003
WITH OUTER LIGHTPIPE PORTS

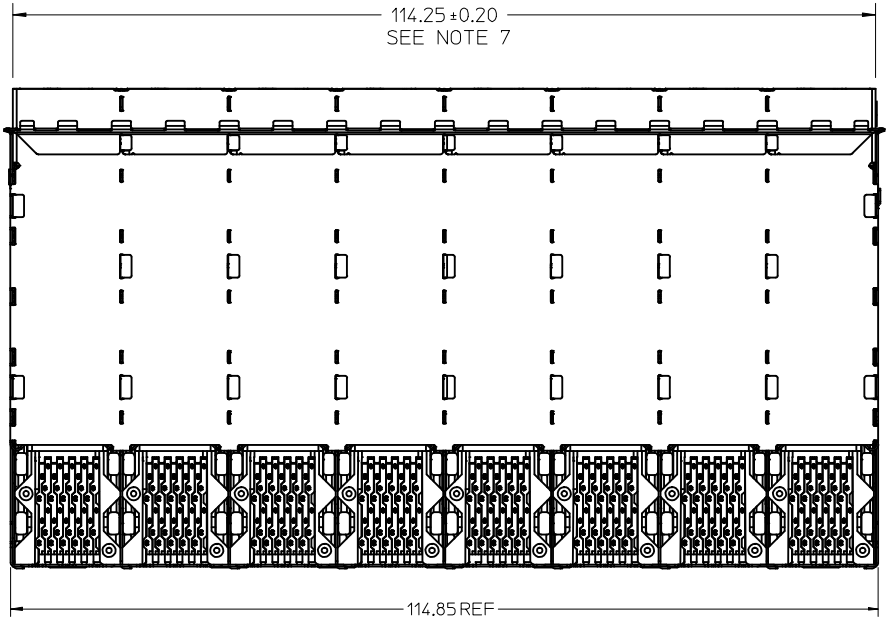

SEE SHEET 1 EC NO: UCP2015-0336 DRW: BARKER 2014/10/08 CHKD: TIBARRA 2014/12/04 APPR: SMILLER 2014/12/16	QUALITY SYMBOLS 	GENERAL TOLERANCES (UNLESS SPECIFIED) <table border="1"> <tr> <th></th> <th>mm</th> <th>INCH</th> </tr> <tr> <td>4 PLACES</td> <td>± .13</td> <td>± .005</td> </tr> <tr> <td>3 PLACES</td> <td>± .15</td> <td>± .006</td> </tr> <tr> <td>2 PLACES</td> <td>± 0.13</td> <td>± .005</td> </tr> <tr> <td>1 PLACE</td> <td>± 0.25</td> <td>± .010</td> </tr> </table>		mm	INCH	4 PLACES	± .13	± .005	3 PLACES	± .15	± .006	2 PLACES	± 0.13	± .005	1 PLACE	± 0.25	± .010	DIMENSION STYLE MM ONLY DRAWN BY DATE JJANTELEZIO 2009/11/03 CHECKED BY DATE JKACHLIC 2009/11/03 APPROVED BY DATE	SCALE 2:1 DESIGN UNITS METRIC 	TITLE STACKED SFP+ 2X8 ASSY WITH ELASTOMERIC GASKET LIGHTPIPES- IMPROVED EMI
		mm	INCH																	
	4 PLACES	± .13	± .005																	
	3 PLACES	± .15	± .006																	
2 PLACES	± 0.13	± .005																		
1 PLACE	± 0.25	± .010																		
MATERIAL NO. SEE TABLE	DOCUMENT NO. SD-170017-002	SHEET NO. 2 OF 5																		
DRAFT WHERE APPLICABLE MUST REMAIN WITHIN DIMENSIONS	SIZE C	THIS DRAWING CONTAINS INFORMATION THAT IS PROPRIETARY TO MOLEX INCORPORATED AND SHOULD NOT BE USED WITHOUT WRITTEN PERMISSION																		
REV B	DESCRIPTION SEE SHEET 1	MOLEX INCORPORATED																		

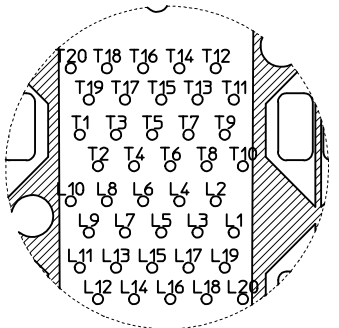
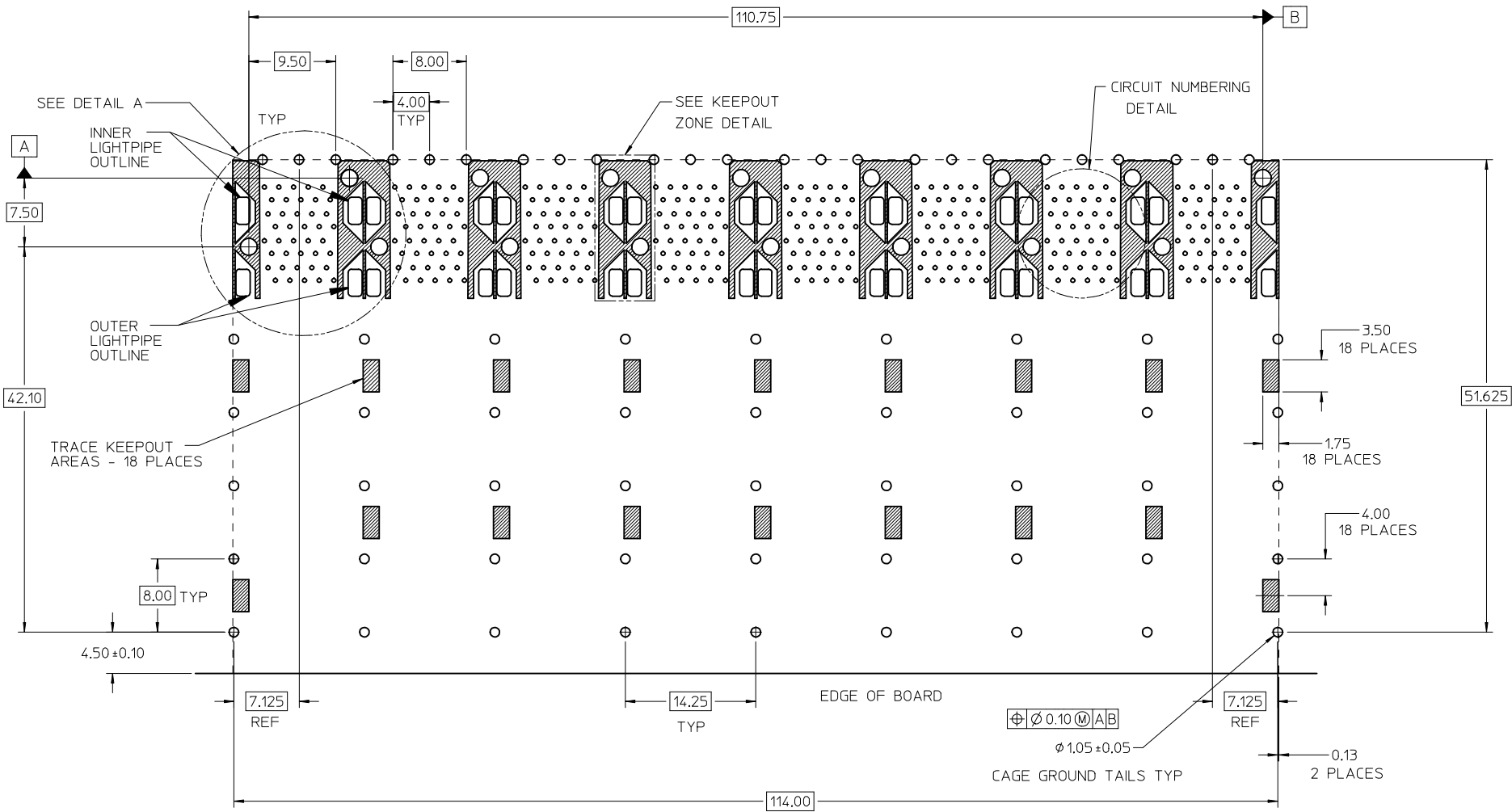

CIRCUIT NUMBERING
COMPONENT SIDE OF BOARD

RECOMMENDED PCB LAYOUT - COMPONENT SIDE
 RECOMMENDED PCB THICKNESS - 2.63 MM (.093 INCH)
 THE ENTIRE AREA OF THE CONNECTOR FOOTPRINT
 TO BE CONSIDERED THE KEEPOUT AREA FOR COMPONENTS
 (OTHER THAN LIGHTPIPE LED'S)
 THIS AREA IS INDICATED BY THE DASHED LINE

CHG DETAIL CALLOUT EC NO: UCP2015-0336 DRWN:BBARKER 2014/10/08 CHKD:TIBARRA 2014/12/04 APPR:SMILLER 2014/12/16	QUALITY SYMBOLS ▽=0 ▽=0 ▽=0	GENERAL TOLERANCES (UNLESS SPECIFIED)		DIMENSION STYLE MM ONLY	SCALE 3:1	DESIGN UNITS METRIC	THIRD ANGLE PROJECTION		
		4 PLACES ± --- ± --- 3 PLACES ± --- ± --- 2 PLACES ± 0.13 ± --- 1 PLACE ± 0.25 ± ---	mmm INCH ± --- ± --- ± 0.13 ± --- ± 0.25 ± ---	DRAWN BY DATE JJANTELEZIO 2009/11/03	CHECKED BY DATE JKACHLIC 2009/11/03	TITLE STACKED SFP+ 2X8 ASSY WITH ELASTOMERIC GASKET LIGHTPIPES- IMPROVED EMI			
		ANGULAR ± 1/2°		APPROVED BY DATE		MOLEX INCORPORATED			
		DRAFT WHERE APPLICABLE MUST REMAIN WITHIN DIMENSIONS		MATERIAL NO. SEE TABLE		DOCUMENT NO. SD-170017-002	SHEET NO. 3 OF 5		

THIS DRAWING CONTAINS INFORMATION THAT IS PROPRIETARY TO MOLEX INCORPORATED AND SHOULD NOT BE USED WITHOUT WRITTEN PERMISSION

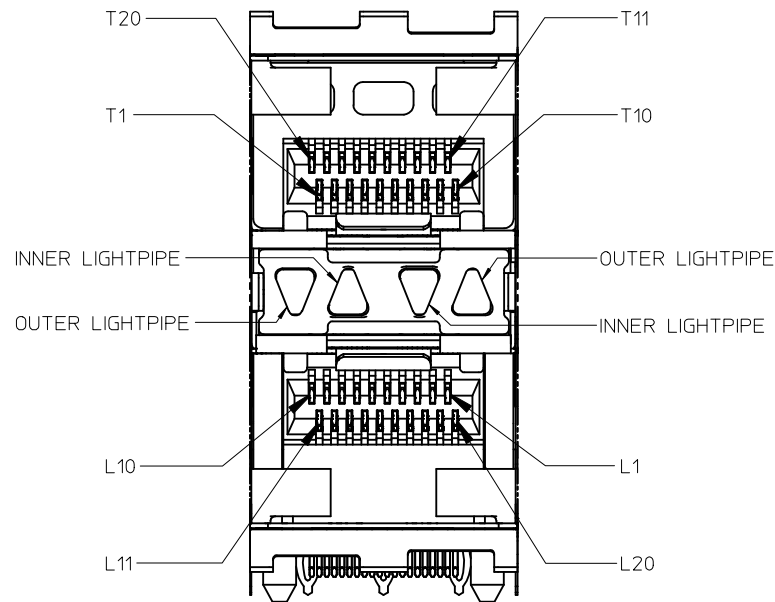

DETAIL B
SCALE 5:1
CIRCUIT NUMBERING
AND LIGHTPIPE
IDENTIFICATION

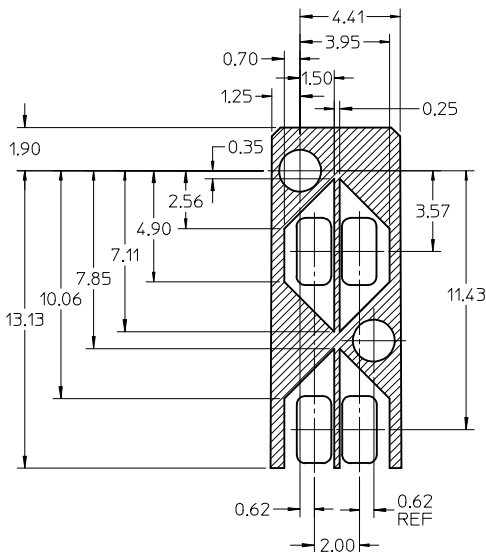

KEEPOUT ZONE DETAIL - LIGHTPIPE AND OTHER ZONES

THE HATCHED AREA IN THIS VIEW INDICATES ZONES THAT ARE OCCUPIED BY THE PLASTIC HOUSING THAT SEATS AGAINST THE PCB AND BY THE VERTICAL METAL CAGE WALL THAT STOPS JUST SHORT OF THE PCB

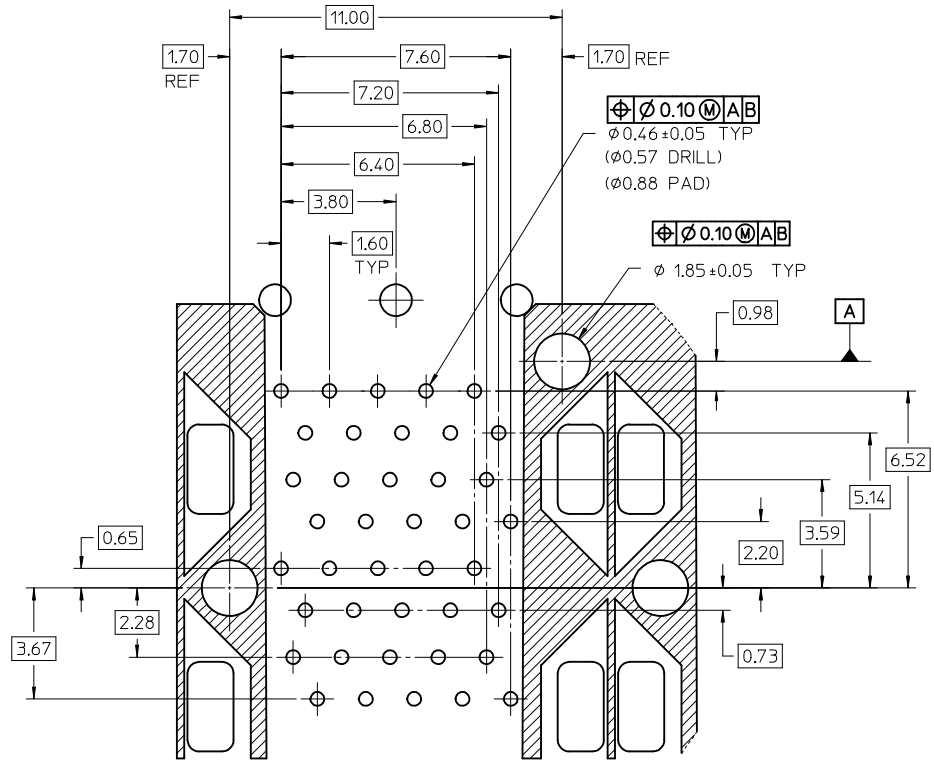

DETAIL A
SCALE 8:1

ADD DETAIL B EC NO: UCP2015-0336 DRW: BARKER 2014/10/08 CHKD: TIBARRA 2014/12/04 APPR: SMILLER 2014/12/16	QUALITY SYMBOLS 	GENERAL TOLERANCES (UNLESS SPECIFIED)		DIMENSION STYLE MM ONLY	SCALE 2:1	DESIGN UNITS METRIC	THIRD ANGLE PROJECTION
		4 PLACES \pm --- \pm --- 3 PLACES \pm --- \pm --- 2 PLACES ± 0.13 \pm --- 1 PLACE ± 0.25 \pm --- ANGULAR $\pm 1/2^\circ$	mm INCH DRAWN BY DATE J JANTELEZIO 2009/11/03 CHECKED BY DATE JKACHLIC 2009/11/03 APPROVED BY DATE	TITLE STACKED SFP+ 2X8 ASSY WITH ELASTOMERIC GASKET LIGHTPIPES- IMPROVED EMI	MATERIAL NO. SEE TABLE	DOCUMENT NO. SD-170017-002	SHEET NO. 4 OF 5
DRAFT WHERE APPLICABLE MUST REMAIN WITHIN DIMENSIONS	SIZE 	THIS DRAWING CONTAINS INFORMATION THAT IS PROPRIETARY TO MOLEX INCORPORATED AND SHOULD NOT BE USED WITHOUT WRITTEN PERMISSION					

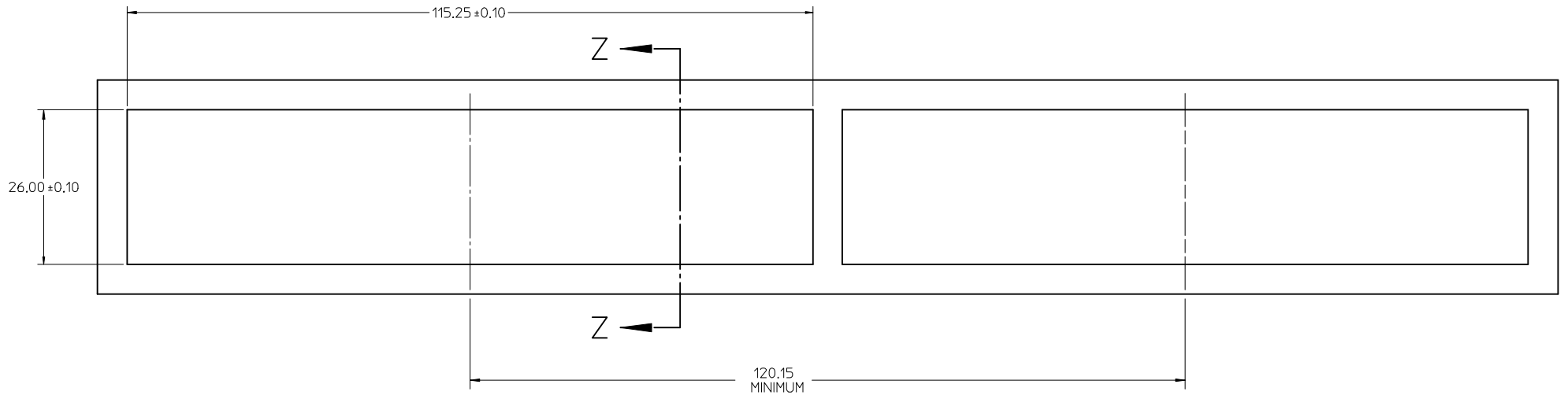

BEZEL CUT-OUT DETAIL
RECOMMENDED BEZEL THICKNESS: 0.8MM - 2.6MM

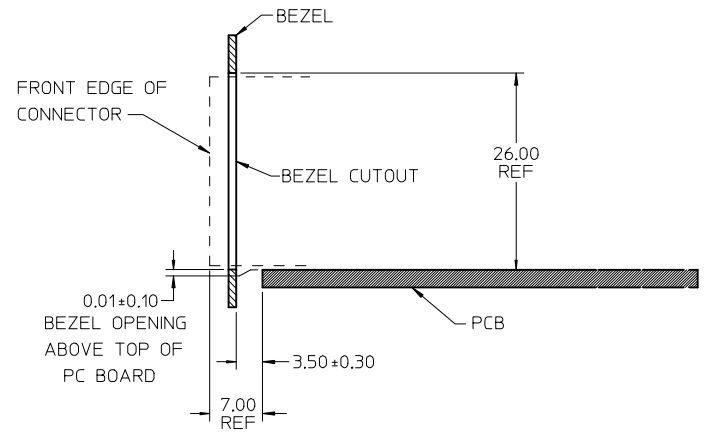

SECTION Z-Z

ADD SECOND BEZEL CUTOUT EC NO: UCP2015-0336 DRWN:BBARKER 2014/10/08 CHKD:TIBARRA 2014/12/04 APPR:SMILLER 2014/12/16	QUALITY SYMBOLS	GENERAL TOLERANCES (UNLESS SPECIFIED)	DIMENSION STYLE	SCALE	DESIGN UNITS	THIRD ANGLE PROJECTION
	▽=0	mm INCH	MM ONLY	2:1	METRIC	
	▽=0	4 PLACES ± --- ± ---	DRAWN BY DATE	TITLE		
	▽=0	3 PLACES ± --- ± ---	JJANTELEZIO 2009/11/03	STACKED SFP+ 2X8 ASSY WITH ELASTOMERIC GASKET LIGHTPIPES- IMPROVED EMI		
	2 PLACES ± 0.13 ± ---	CHECKED BY DATE	molex MOLEX INCORPORATED			
	1 PLACE ± 0.25 ± ---	APPROVED BY DATE	MATERIAL NO. SEE TABLE			DOCUMENT NO. SD-170017-002
	ANGULAR ± 1/2°		SIZE C THIS DRAWING CONTAINS INFORMATION THAT IS PROPRIETARY TO MOLEX INCORPORATED AND SHOULD NOT BE USED WITHOUT WRITTEN PERMISSION			SHEET NO. 5 OF 5