

10	9	8	7	6	5	4	3	2	1		
MATERIAL NO. LOOSE PIECE	ENG. NO.	MATERIAL NO. TAPE MOUNTED	ENG. NO.	STUD SIZE	"S" ±.005/0.13	"W" MAX.	"C" MIN.	"L" MAX.	"ID" MIN.	STOCK THICKNESS	"H" ±.020/0.51
190690027	AA-120-02	190690028	AA-120-02T	2	.094/(2.39)	.235/(6.00)	.157/(3.99)	.484/(12.29)	.062/(1.57)	.028/(0.71)	1.155/(29.34)
190690029	AA-120-04	190690030	AA-120-04T	4	.119/(3.02)						
190690031	AA-120-06	190690032	AA-120-06T	6	.146/(3.71)	.322/(8.18)	.270/(6.86)	.641/(16.28)	.062/(1.57)	.028/(0.71)	1.155/(29.34)
190690033	AA-121-06	190690034	AA-121-06T	6	.146/(3.71)						
190690035	AA-121-08	190690036	AA-121-08T	8	.173/(4.39)						
190690037	AA-121-10	190690038	AA-121-10T	10	.198/(5.03)						
190690039	AA-121-209	190690475	AA-121-209T	209	.209/(5.18)	.477/(12.11)	.386/(9.80)	.835/(21.21)	.062/(1.57)	.028/(0.71)	1.155/(29.34)
190690040	AA-122-10	190690041	AA-122-10T	10	.198/(5.03)						
190690042	AA-122-14	190690044	AA-122-14T	14	.265/(6.71)	.544/(13.82)	.552/(14.02)	1.034/(26.26)	.055/(1.40)	.031/(0.79)	1.342/(34.09)
190690045	AA-122-56	190690046	AA-122-56T	56	.328/(8.33)						
190690047	AA-126-10	-----	-----	10	.198/(5.03)						
190690048	AA-126-14	190690128	AA-126-14T	14	.265/(6.71)						
190690051	AA-126-56	-----	-----	56	.328/(8.33)	.264/(6.70)	.240/(6.10)	.582/(14.78)	.062/(1.57)	.028/(0.71)	1.155/(29.34)
190690049	AA-126-38	190690050	AA-126-38T	38	.390/(9.91)						
190690052	AA-132-04	190690053	AA-132-04T	4	.119/(3.02)	.283/(7.20)	.240/(6.10)	.591/(15.00)	.062/(1.57)	.028/(0.71)	1.155/(29.34)
190690054	AA-132-06	190690055	AA-132-06T	6	.146/(3.71)						
190690056	AA-132-08	190690057	AA-132-08T	8	.173/(4.39)	.197/(5.00)	.173/(4.40)	.490/(12.40)	.055/(1.40)	.031/(0.79)	1.155/(29.34)
190690061	AA-133-10	190690062	AA-133-10T	10	.198/(5.03)						
190690024	AA-1111-02	190690191	AA-1111-02T	2	.094/(2.39)	.119/(3.02)	.173/(4.40)	.490/(12.40)	.055/(1.40)	.031/(0.79)	1.155/(29.34)
190690025	AA-1111-04	190690026	AA-1111-04T	4	.119/(3.02)						

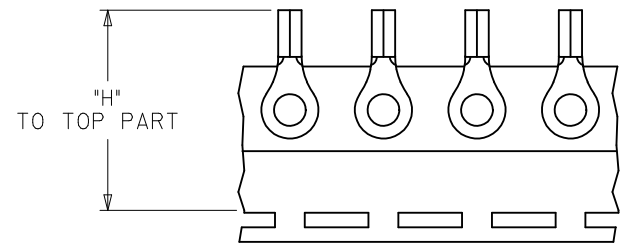
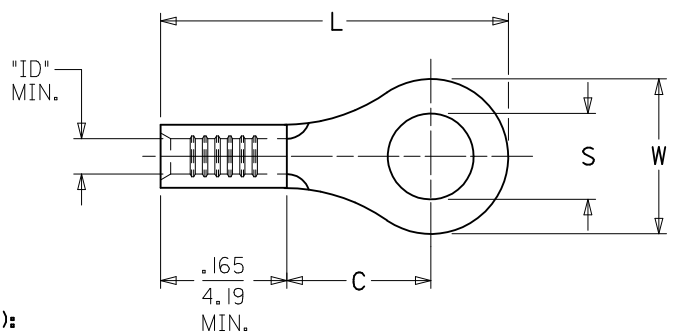

SALES DRAWING

- NOTE(S):**
1. MATERIAL: COPPER.
 2. PLATING: ELECTRO-TIN.
 3. ALL DIMENSIONS IN INCHES/(MM).
- WIRE SIZE:
22-18 AWG
0.25-1.5 MM²
4. PARTS ARE ROHS COMPLIANT.

STDIZE STUD TOL EC NO: WNA2011-0225 DRW: HETHRODAHL 2010/10/29 CHKD: JMACNEIL 2010/11/17 APPR: JMACNEIL 2010/11/17 C2	QUALITY SYMBOLS ▽=0 ▽=0	GENERAL TOLERANCES (UNLESS SPECIFIED) <table border="1"> <tr> <th></th> <th>mm</th> <th>INCH</th> </tr> <tr> <td>4 PLACES</td> <td>±---</td> <td>±---</td> </tr> <tr> <td>3 PLACES</td> <td>±---</td> <td>±---</td> </tr> <tr> <td>2 PLACES</td> <td>±---</td> <td>±---</td> </tr> <tr> <td>1 PLACE</td> <td>±---</td> <td>±---</td> </tr> </table>		mm	INCH	4 PLACES	±---	±---	3 PLACES	±---	±---	2 PLACES	±---	±---	1 PLACE	±---	±---	DIMENSION STYLE IN/MM	SCALE ---	DESIGN UNITS INCH	THIRD ANGLE PROJECTION
		mm	INCH																		
	4 PLACES	±---	±---																		
	3 PLACES	±---	±---																		
2 PLACES	±---	±---																			
1 PLACE	±---	±---																			
DRAWN BY BDEROSS	DATE 2000/6/13	TITLE RING TONGUE TERMINAL KRIMPTITE, 100 SERIES 22-18 AWG																			
CHECKED BY JHACKNEY	DATE 2000/6/13	MOLEX INCORPORATED																			
APPROVED BY JMACNEIL	DATE 2010/11/17	MATERIAL NO. SEE CHART	DOCUMENT NO. SD-19069-004	SHEET NO. 1 OF 1																	

10	9	8	7	6	5	4	3	2	1
MATERIAL NO. LOOSE PIECE	ENG. NO.	MATERIAL NO. TAPE MOUNTED	ENG. NO.	STUD SIZE	"S" ±.005/0.13	STOCK THICKNESS	FINISH		
190690200	C-128-04	190690147	C-128-04T	4	.119/(3.02)	.040/(1.02)	SEE NOTE 2		
190690202	C-128-06	190690148	C-128-06T	6	.146/(3.71)				
190690205	C-128-08	190690208	C-128-08T	8	.173/(4.39)				
190690209	C-128-10	190690212	C-128-10T	10	.198/(5.03)				
190690215	C-128-209	---	---	209	.209/(5.18)				
192030159	C-U-128-06	192030111	C-U-128-06T	6	.146/(3.71)	.038/(0.97)	SEE NOTE 3		
192030160	C-U-128-08	192030112	C-U-128-08T	8	.173/(4.39)				
192030113	C-U-128-10	192030114	C-U-128-10T	10	.198/(5.03)				
190690682	C-128-10-AU	---	---	10	.198/(5.03)	.040/(1.02)	SEE NOTE 3		

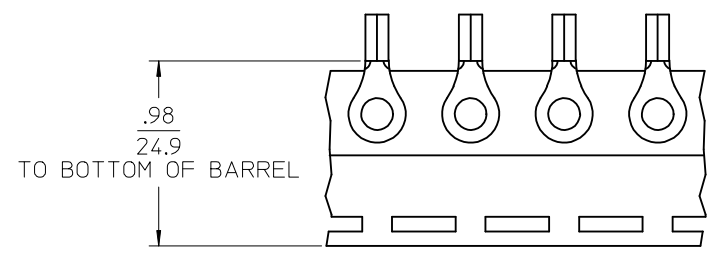
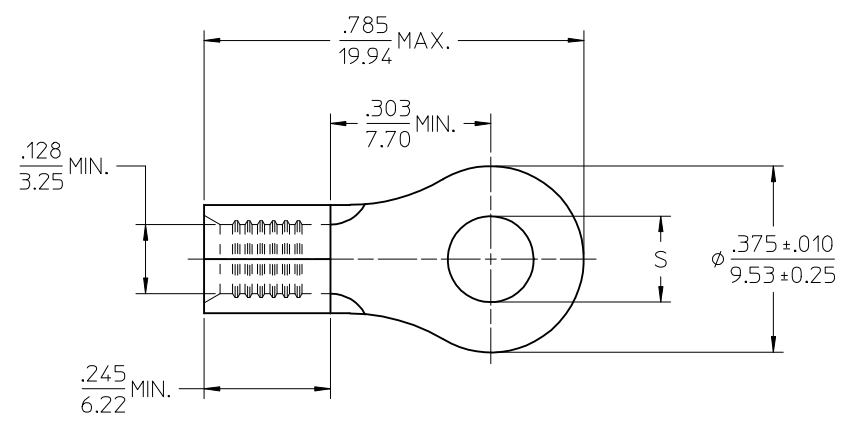

SALES DRAWING

- NOTES:
1. MATERIAL: COPPER.
 2. FINISH: TIN PLATING, 100(2.5)µin(µm) MIN
 3. FINISH: GOLD, 50(1.25)µin(µm) MIN. OVER NICKEL, 50(1.25)µin(µm) MIN. PLATING.
 4. WIRE SIZE: 12-10 AWG, 4.0-6.0 MM²
 5. PARTS ARE ROHS COMPLIANT.

RELEASED EC NO: IFC2015-0823 DRAWN: GROSAS01 2014/10/30 CHKD: JMACNEIL 2014/10/30 APPR: JMACNEIL 2014/11/19 REV A	QUALITY SYMBOLS	GENERAL TOLERANCES (UNLESS SPECIFIED)	DIMENSION STYLE	SCALE	DESIGN UNITS	THIRD ANGLE PROJECTION	
		mm	INCH	IN/MM	---	INCH	
		4 PLACES ± ---	± ---	DRAWN BY DATE	TITLE		
		3 PLACES ± ---	± ---	BDEROSS 2000/6/13		RING TONGUE TERMINAL KRIMPTITE, 128 SERIES 12-10 AWG	
	2 PLACES ± ---	± ---	CHECKED BY DATE				
	1 PLACE ± ---	± ---	JMACNEIL 2014/10/30	APPROVED BY DATE			
	ANGULAR ± ---°		JMACNEIL 2014/11/19				
	DRAFT WHERE APPLICABLE MUST REMAIN WITHIN DIMENSIONS		MATERIAL NO.	DOCUMENT NO.	SHEET NO.		
			SEE CHART	SD-19069-020	1 OF 1		
			THIS DRAWING CONTAINS INFORMATION THAT IS PROPRIETARY TO MOLEX INCORPORATED AND SHOULD NOT BE USED WITHOUT WRITTEN PERMISSION				