

13	12	11	10	9
PART NUMBER	ENGINEERING NUMBER	FINISH LENGTH		
1300060217	103000A01F030	3.00' +1.75" -0 [0.9M +44.5 -0]		
1300060221	103000A01F060	6.00' +3.50" -0 [1.8M +88.9 -0]		
1300060229	103000A01F090	9.00' +3.50" -0 [2.7M +88.9 -0]		
1300060232	103000A01F120	12.00' +6.50" -0 [3.7M +165.1 -0]		
1300060237	103000A01F150	15.00' +6.50" -0 [4.6M +165.1 -0]		
1300060241	103000A01F200	20.00' +6.50" -0 [6.1M +165.1 -0]		
1300060246	103000A01F250	25.00' +12.50" -0 [7.6M +317.5 -0]		
1300060250	103000A01F300	30.00' +12.50" -0 [9.1M +317.5 -0]		
1300060253	103000A01F350	35.00' +12.50" -0 [10.7M +317.5 -0]		
1300060254	103000A01F400	40.00' +12.50" -0 [12.2M +317.5 -0]		

8	7	6	5	4	3	2	1
PART NUMBER	ENGINEERING NUMBER	FINISH LENGTH					
1300060257	103000A01F450	45.00' +12.50" -0 [13.7M +317.5 -0]					
1300060258	103000A01F500	50.00' +24.50" -0 [15.2M +622.3 -0]					

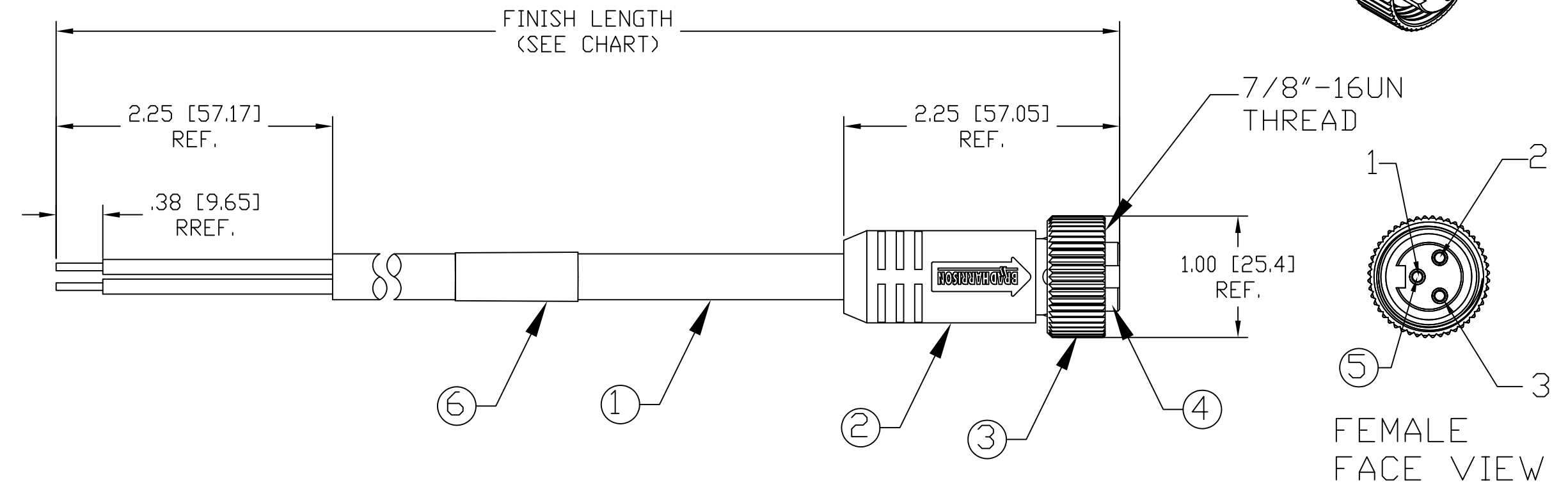
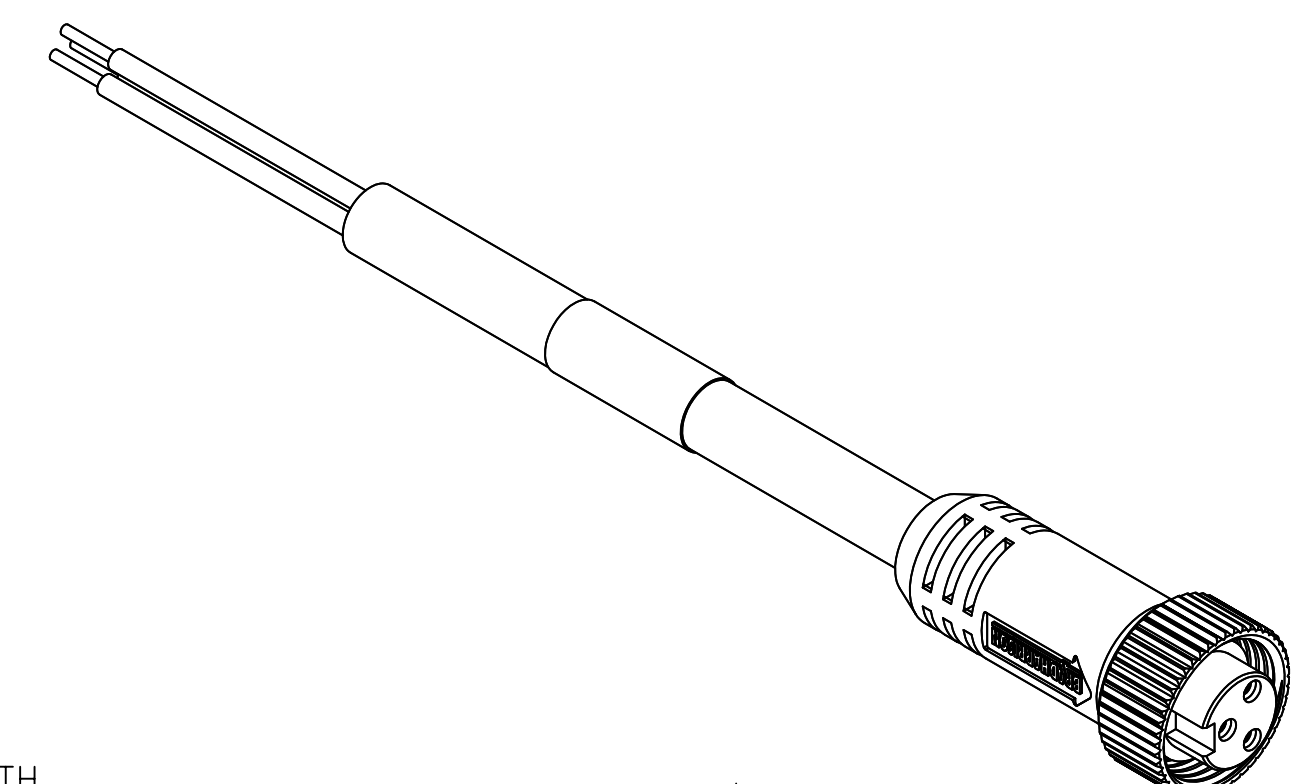

NOTE

- 1) MATERIAL: SEE TABLE
- 2) FINISHES: SEE TABLE
- 3) WRAP LABEL IS MARKED WITH P/N, DATE CODE, VOLTAGE & AMPERAGE
- 4) MATES WITH: MINI CHANGE, 3 POLE RECEPTACLE
- 5) ELECTRICAL DATA:  
 INLINE CORDSET  
 FEMALE A-SIZE WITH FLYING LEADS  
 16AWG UNSHIELDED  
 POLES: 3  
 MAX. VOLTAGE: 600V  
 MAX. CURRENT 13A  
 PROTECTION IP67  
 TEMPERATURE RANGE: -20°C TO 105°C
- 6) PACKAGING:  
 CABLE ASSEMBLIES ARE BAGGED SEPERATELY  
 IN POLY BAGS WITH BAR CODE LABEL ATTACHED  
 TO OUTSIDE OF BAG.
- 7) ASSEMBLY IS RoHS COMPLIANT.
- 8) CERTIFICATION  
 UL RECOGNIZED, FILE NO. E152210  
 CSA CERTIFIED, FILE NO. LR6837

P1

1	GREEN/YELLOW-GRD
2	BLACK
3	WHITE

WIRING DIAGRAM

ITEM	QTY.	DESCRIPTION	MATERIAL	FINISH
6	1	LABEL	PLASTIC FILM	BLACK/YELLOW
5	3	CONTACT SOCKET	COPPER ALLOY	GOLD PLATED
4	1	INSERT	PVC	YELLOW
3	1	COUPLING NUT	ZINC DIE CAST	BLACKE-COATED
2	1	OVERMOLD	PVC	YELLOW
1	1	CABLE, 16AWG-3 TYPE ST00W	PVC	YELLOW

CORRECT COLOR ROTATION EC NO: WNA2010-0389 DRWN: TWOLDEGE 12/17/09 CH'KD: BWOODMAN APPR: JFMURPHY 2010/01/04	DESCRIPTION REV	<b>QUALITY SYMBOL</b> ▽=0 ◻=0	<b>GENERAL TOLERANCES (UNLESS SPECIFIED)</b> <table border="1"> <tr> <th></th> <th>mm</th> <th>INCH</th> </tr> <tr> <td>4 PLACES</td> <td>±---</td> <td>±---</td> </tr> <tr> <td>3 PLACES</td> <td>±.005</td> <td>±.005</td> </tr> <tr> <td>2 PLACES</td> <td>±.013</td> <td>±.010</td> </tr> <tr> <td>1 PLACE</td> <td>±.025</td> <td>±.020</td> </tr> </table>		mm	INCH	4 PLACES	±---	±---	3 PLACES	±.005	±.005	2 PLACES	±.013	±.010	1 PLACE	±.025	±.020	<b>DIMENSION STYLE</b> IN/MM DRAWN BY: TWOLDEGE DATE: 2009/07/10 CHECKED BY: BWOODMAN DATE: 2009/07/10 APPROVED BY: JFMURPHY DATE: 2010/01/04	SCALE: 1:1 DESIGN UNITS: INCH THIRD ANGLE PROJECTION
			mm	INCH																
		4 PLACES	±---	±---																
		3 PLACES	±.005	±.005																
2 PLACES	±.013	±.010																		
1 PLACE	±.025	±.020																		
DRAFT WHERE APPLICABLE MUST REMAIN WITHIN DIMENSIONS			MATERIAL NO.: SEE CHART SIZE: C	TITLE: MINI CHANGE ASSEMBLY 3-POLE FEMALE ST 16/3AWG PVC MOLEX INCORPORATED DOCUMENT NO.: SD-130006-008 SHEET NO.: 1 OF 1																
THIS DRAWING CONTAINS INFORMATION THAT IS PROPRIETARY TO MOLEX INCORPORATED AND SHOULD NOT BE USED WITHOUT WRITTEN PERMISSION																				