

FACE VIEW - MALE INSERT

SCALE 2 : 1

<p>1 WHITE 2 BLACK</p>	<p>1 GREEN/YELLOW 2 BLACK 3 WHITE</p>	<p>1 BLACK 2 WHITE 3 RED 4 GREEN/YELLOW</p>	<p>1 WHITE 2 RED 3 GREEN/YELLOW 4 ORANGE 5 BLACK</p>	<p>1 WHITE 2 RED 3 GREEN/YELLOW 4 ORANGE 5 BLACK 6 BLUE</p>

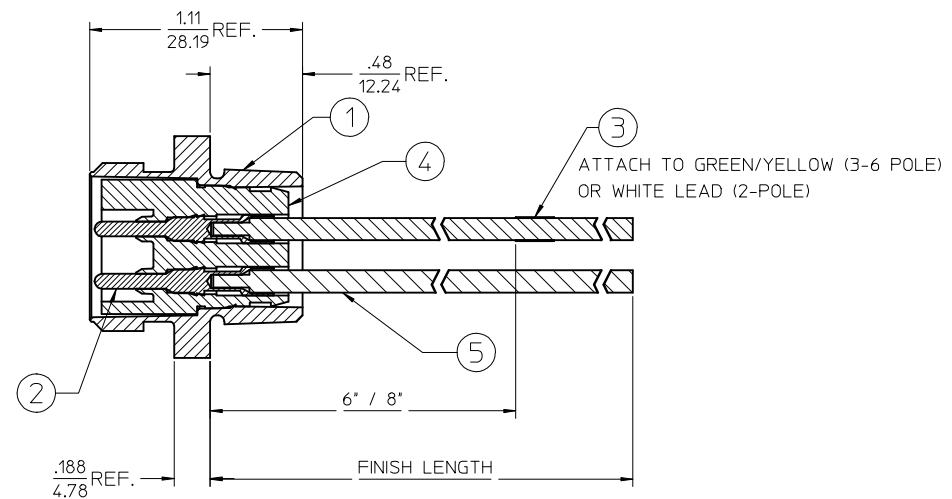
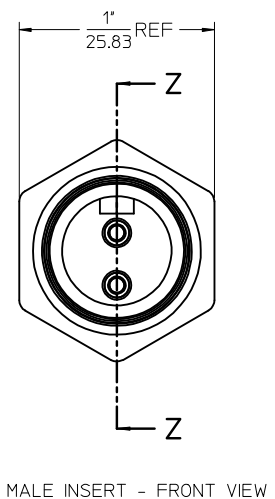

FINAL ASSEMBLY
1300130076

ENTER DESCRIPTION EC NO: MNA2010-0057 DRWN: NKUMAR01 2009/07/31 CHKD: JFMURPHY APPR: JFMURPHY 2009/08/10 REV: A	QUALITY SYMBOLS ▽=0 ▽=0	GENERAL TOLERANCES (UNLESS SPECIFIED) <table border="1" style="width: 100%; border-collapse: collapse;"> <thead> <tr> <th></th> <th>mm</th> <th>INCH</th> </tr> </thead> <tbody> <tr> <td>4 PLACES ±</td> <td>---</td> <td>---</td> </tr> <tr> <td>3 PLACES ±</td> <td>---</td> <td>---</td> </tr> <tr> <td>2 PLACES ±</td> <td>---</td> <td>---</td> </tr> <tr> <td>1 PLACE ±</td> <td>---</td> <td>---</td> </tr> </tbody> </table> ANGULAR ±1/2°		mm	INCH	4 PLACES ±	---	---	3 PLACES ±	---	---	2 PLACES ±	---	---	1 PLACE ±	---	---	DIMENSION STYLE IN/MM DRAWN BY: NKUMAR01 DATE: 31/07/09 CHECKED BY: BWOODMAN DATE: 31/07/09 APPROVED BY: JFMURPHY DATE: 31/07/09	SCALE 2:1 DESIGN UNITS INCH THIRD ANGLE PROJECTION	TITLE MC 2P MR 12IN. 16/1 PVC	MATERIAL NO. 9999999999	DOCUMENT NO. SD-130013-076	SHEET NO. 1 OF 2
		mm	INCH																				
	4 PLACES ±	---	---																				
	3 PLACES ±	---	---																				
2 PLACES ±	---	---																					
1 PLACE ±	---	---																					
DRAFT WHERE APPLICABLE MUST REMAIN WITHIN DIMENSIONS		MOLEX INCORPORATED		THIS DRAWING CONTAINS INFORMATION THAT IS PROPRIETARY TO MOLEX INCORPORATED AND SHOULD NOT BE USED WITHOUT WRITTEN PERMISSION																			

MALE RECEPTACLE ASSEMBLY

SI. No.	DESCRIPTION	MATERIAL	FINISH	QUANTITY				
				2 POLE	3 POLE	4 POLE	5 POLE	6 POLE
1	RECEPTACLE SHELL	ZINC DIECAST	BLACK E-COAT	1	1	1	1	1
2	PIN CONTACT 16AWG	COPPER ALLOY	GOLD PLATED	2	3	4	5	6
3	LABEL	PLASTIC FILM	BLACK/YELLOW	1	1	1	1	1
4	2P MALE INSERT PVC A SIZE	PVC	YELLOW	1				
	3P MALE INSERT PVC A SIZE	PVC	YELLOW		1			
	4P MALE INSERT PVC A SIZE	PVC	YELLOW			1		
	5P MALE INSERT PVC A SIZE	PVC	YELLOW				1	
5	#16-1 WHT PVC WIRE UL1015	PVC JACKET	WHITE	1	1	1	1	1
	#16-1 RED PVC WIRE UL1015	PVC JACKET	RED					1
	#16-1 ORN PVC WIRE UL1015	PVC JACKET	ORANGE		1	1	1	1
	#16-1 GRN/YEL PVC WIRE UL1015	PVC JACKET	GREEN/YELLOW				1	1
	#16-1 BLU PVC WIRE UL1015	PVC JACKET	BLUE			1	1	1
	#16-1 BLK PVC WIRE UL1015	PVC JACKET	BLACK	1	1	1	1	1

PART NUMBER	DESCRIPTION	FINISHED LENGTH
1300130076	1R2006A20A120	12.0" +.75" -0 [0.3M +19.1MM -0]
1300130084	1R2006A20F060	6.0' +2.19" -0 [1.8M +55.6MM -0]
1300130202	1R3006A20A120	12.0" +.75" -0 [0.3M +19.1MM -0]
1300130215	1R3006A20F060	6.0' +2.19" -0 [1.8M +55.6MM -0]
1300130353	1R4006A20A120	12.0" +.75" -0 [0.3M +19.1MM -0]
1300130361	1R4006A20F060	6.0' +2.19" -0 [1.8M +55.6MM -0]
1300130493	1R5006A20A120	12.0" +.75" -0 [0.3M +19.1MM -0]
1300130503	1R5006A20F060	6.0' +2.19" -0 [1.8M +55.6MM -0]
1300130593	1R6006A20A120	12.0" +.75" -0 [0.3M +19.1MM -0]
1300130605	1R6006A20F060	6.0' +2.19" -0 [1.8M +55.6MM -0]

POLE COUNT	MAX. VOLTAGE RATING	MAX. CURRENT RATING
2 POLE	600 VOLTS	13 AMPS
3 POLE	600 VOLTS	13 AMPS
4 POLE	600 VOLTS	10 AMPS
5 POLE	600 VOLTS	8 AMPS
6 POLE	600 VOLTS	8 AMPS

ENTER DESCRIPTION EC NO: MNA2010-0057 DRAWN BY: DRWINAKUMAR01 2009/07/31 CHKD: APPR: JFMURPHY 2009/08/10 REV: A	QUALITY SYMBOLS ▽=0 ▽=0	GENERAL TOLERANCES (UNLESS SPECIFIED)		DIMENSION STYLE IN/MM	SCALE 2:1	DESIGN UNITS INCH	THIRD ANGLE PROJECTION
		4 PLACES ± --- ± ---	DRAWN BY NKUMAR01	DATE 31/07/09	TITLE MC 2P MR 12IN. 16/1 PVC		
		3 PLACES ± --- ± ---	CHECKED BY BWOODMAN	DATE 31/07/09			
		2 PLACES ± --- ± ---	APPROVED BY JFMURPHY	DATE 31/07/09			
1 PLACE ± --- ± ---	MATERIAL NO. 9999999999		DOCUMENT NO. SD-130013-076	SHEET NO. 2 OF 2			
DRAFT WHERE APPLICABLE MUST REMAIN WITHIN DIMENSIONS				THIS DRAWING CONTAINS INFORMATION THAT IS PROPRIETARY TO MOLEX INCORPORATED AND SHOULD NOT BE USED WITHOUT WRITTEN PERMISSION			