

MATERIAL NUMBER	OLD PART NUMBER	FINISH LENGTH
130013-0614	1R6G04A20A120	1.0'+.75"-0 [.3M+19.1-0]

VOLTAGE RATING	600 VAC/VDC
AMPERAGE RATING	8A
PROJECTION	IP67
OPERATING TEMPERATURE	-20° C TO 105° C
UL CERTIFICATIONS	UL RECOGNIZED, FILE NO. E152210
CSA CERTIFICATIONS	CSA CERTIFIED, FILE NO. LR6837

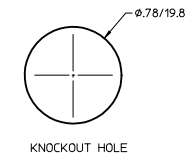
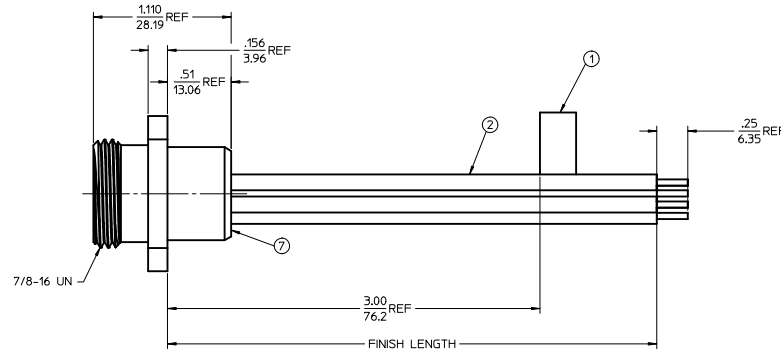
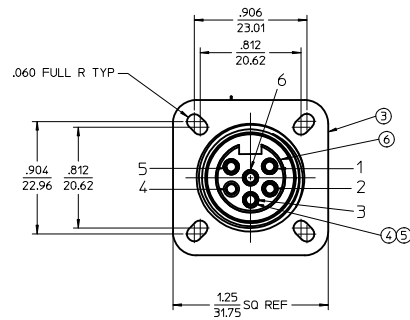
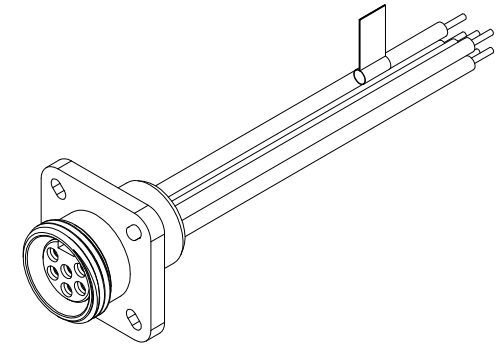

WIRING DIAGRAM

- 1 > WHITE
- 2 > RED
- 3 > GREEN/YELLOW-GND
- 4 > ORANGE
- 5 > BLACK
- 6 > BLUE

ITEM.	QTY.	COMPONENT	MATERIAL	FINISH
1	1	FLAG LABEL	PLASTIC FILM	BLACK/YELLOW
2	6	CONDUCTOR-16 AWG, 26X#30 COPPER STRANDING 600V	PVC	SEE WIRING DIAGRAM
3	1	RECEPTACLE SHELL	ALUMINUM	ANODIZED
4	6	SOCKET SLEEVE	STAINLESS STEEL	
5	6	CONTACT SOCKET	COPPER ALLOY	GOLD PLATED
6	1	6 POLE INSERT	PVC	YELLOW
7	1	POTTING	EPOXY	BLACK

CREATE DOC EC NO: WNA2010-0423 DRAWN/RUPERT 2010/01/08 CHKD/B. RUPERT 2010/01/14 APPR./J. MURPHY 2010/01/14	QUALITY SYMBOLS	GENERAL TOLERANCES (UNLESS SPECIFIED)	DIMENSION STYLE	SCALE	DESIGN UNITS	THIRD ANGLE PROJECTION	
	▼=0 ▽=0	mm INCH 4 PLACES ±--- ±--- 3 PLACES ±--- ±.005 2 PLACES ±0.013 ±--- 1 PLACE ±--- ±--- ANGULAR ±1/2°	IN/MM 2:1	INCH	INCH	INCH	INCH
		DRAFT WHERE APPLICABLE MUST REMAIN WITHIN DIMENSIONS	DRAWN BY DATE B. RUPERT 01/07/2010 CHECKED BY DATE B. WOODMAN 01/07/2010 APPROVED BY DATE J. MURPHY 2010/01/14	TITLE FEMALE FLANGED RECEPTACLE MINI-CHANGE 6P 16AWG PVC			MATERIAL NO. SEE CHART
			MOLEX INCORPORATED			DOCUMENT NO. SD-130013-021	SHEET NO. 1 OF 1