

PART NUMBER		STATUS	CKTS	DIM A	DIM B	DIM C	DIM D	POWER POS.	DIM E
TIN	TIN FINISH/TREND								
762910008	762910008	NOT TOOLED	8	8.19	4.40	5.65	4.25	-	10.84
762910014	762910014	NOT TOOLED	14	10.44	6.65	7.90	6.50	-	10.84
762910020	762910020	NOT TOOLED	20	12.69	8.90	10.15	8.75	-	10.84
762910026	762910026	NOT TOOLED	26	14.94	11.15	12.40	11.00	-	10.84
762910032	762910032	NOT TOOLED	32	17.19	13.40	14.65	13.25	-	10.84
762910038	762910038	NOT TOOLED	38	19.44	15.60	16.90	15.50	-	10.84
762910044	762910044	NOT TOOLED	44	21.69	17.90	19.15	17.75	-	10.84
762910050	762910050	NOT TOOLED	50	23.94	20.15	21.40	20.00	-	10.84
762910056	762910056	NOT TOOLED	56	26.19	22.40	23.65	22.25	-	10.84
762910062	762910062	NOT TOOLED	62	28.44	24.65	25.90	24.50	-	10.84
762910068	762910068	NOT TOOLED	68	30.69	26.90	28.15	26.75	-	10.84
762910074	762910074	NOT TOOLED	74	32.94	29.15	30.40	29.00	-	10.84
762910080	762910080	NOT TOOLED	80	35.19	31.40	32.65	31.25	-	10.84
762910086	762910086	NOT TOOLED	86	37.44	33.65	34.90	33.50	-	10.84
762910092	762910092	NOT TOOLED	92	39.69	35.90	37.15	35.75	-	10.84
762910098	762910098	NOT TOOLED	98	41.94	38.15	39.40	38.00	-	10.84
762911004	762911004	NOT TOOLED	104	44.19	40.40	41.65	40.25	-	10.84
762911010	762911010	NOT TOOLED	110	46.44	42.65	43.90	42.50	-	10.84
762911016	762911016	NOT TOOLED	116	48.69	44.90	46.15	44.75	-	10.84
762911022	762911022	NOT TOOLED	122	50.94	47.15	48.40	47.00	-	10.84
762911028	762911028	NOT TOOLED	128	53.19	49.40	50.65	49.25	-	10.84
762911034	762911034	NOT TOOLED	134	55.44	51.65	52.90	51.50	-	10.84
762911040	762911040	NOT TOOLED	140	57.69	53.90	55.15	53.75	-	10.84
762911046	762911046	NOT TOOLED	146	59.94	56.15	57.40	56.00	-	10.84
762911052	762911052	NOT TOOLED	152	62.19	58.40	59.65	58.25	-	10.84
762911058	762911058	NOT TOOLED	158	64.44	60.65	61.90	60.50	-	10.84
762911064	762911064	NOT TOOLED	164	66.69	62.90	64.15	62.75	-	10.84
762911070	762911070	NOT TOOLED	170	68.94	65.15	66.40	65.00	-	10.84
762911076	762911076	NOT TOOLED	176	71.19	67.40	68.65	67.25	-	10.84
762911082	762911082	NOT TOOLED	182	73.44	69.65	70.90	69.50	-	10.84
762911088	762911088	NOT TOOLED	188	75.69	71.90	73.15	71.75	-	10.84
762911094	762911094	NOT TOOLED	194	77.94	74.15	75.40	74.00	-	10.84
762911099	762911099	NOT TOOLED	199	80.19	76.40	77.65	76.25	-	10.84
762912002	762912002	NOT TOOLED	202	82.44	78.65	79.90	78.50	-	10.84
762912008	762912008	NOT TOOLED	208	84.69	80.90	82.15	80.75	-	10.84
76291214	76291214	NOT TOOLED	214	86.94	83.15	84.40	83.00	-	10.84
76291220	76291220	NOT TOOLED	220	89.19	85.40	86.65	85.25	-	10.84
76291226	76291226	NOT TOOLED	226	91.44	87.65	88.90	87.50	-	10.84
76291226	76291226	NOT TOOLED	226	91.44	87.65	88.90	87.50	-	10.15
76291232	76291232	NOT TOOLED	232	93.69	89.90	91.15	89.75	-	10.84
76291238	76291238	NOT TOOLED	238	95.94	92.15	93.40	92.00	-	10.84
76291244	76291244	NOT TOOLED	244	98.19	94.40	95.65	94.25	-	10.84
76291250	76291250	NOT TOOLED	250	100.44	96.65	97.90	96.50	-	10.84

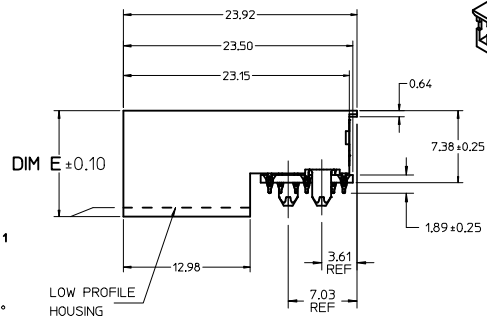

LOW PROFILE

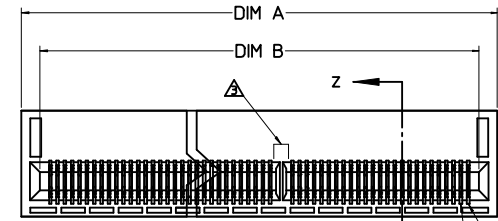
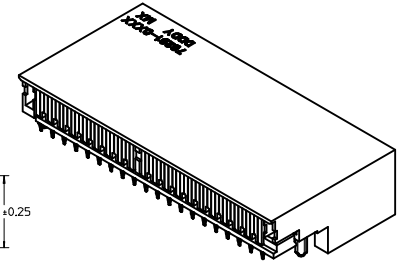
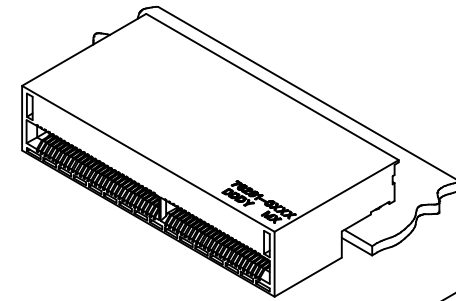
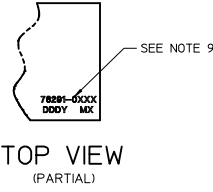
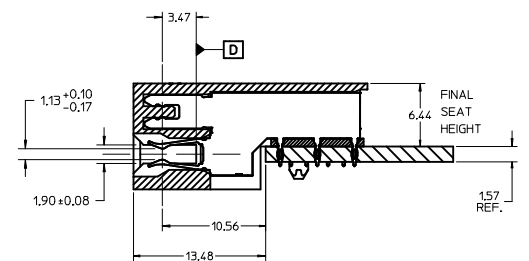
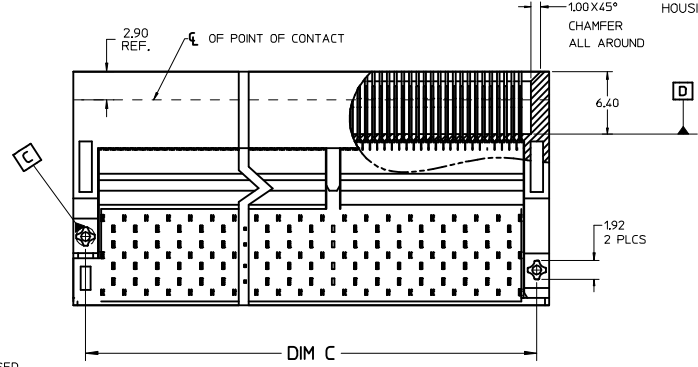

SECTION Z-Z

- NOTES:
- MATERIAL -
CONNECTOR HOUSING - GLASS FILLED LCP, 94V-0, BLACK
OVERMOLDING ON TERMINALS: GLASS FILLED LCP, 94V-0, BLACK
TERMINALS: COPPER ALLOY, SPRING TEMPER
 - TERMINAL FINISH:
CONTACT AREA: .75µm HARD GOLD OVER 3.8µm MIN NICKEL.
COMPLIANT AREA: .75-1.50µm TIN OVER .75µm - 1.50µm NICKEL.
 - FOR CIRCUIT SIZES GREATER THAN 170, A CENTER ALIGNMENT KEY WILL BE USED.
 - REFER TO PS-76291-001 PRODUCT SPEC FOR ALL ELECTRICAL, MECHANICAL, AND ENVIRONMENTAL SPECIFICATIONS.
 - REFER TO PK-76291-001 FOR ALL PACKAGING SPECIFICATIONS.
 - REFER TO AS-76291-001 FOR BOARD APPLICATION INFORMATION.
 - MODULE BOARD CONTACT PAD PLATING TO BE .76µm MIN HARD GOLD OVER 2.54µm MIN NICKEL.
 - MODULE BOARD CONTACT PAD SURFACE ROUGHNESS NOT TO EXCEED Ra 0.2µm.
 - PART TO BE LASER MARKED WITH PART NUMBER, WHERE XXX IS THE CIRCUIT SIZE OR POWER WAFER OPTION, MANUFACTURING FACILITY, AND DATE CODE IN THE FORMAT OF: DAY OF THE YEAR AND LAST DIGIT OF THE YEAR: DDDY

Rev: DIM E LowProfile EC NO: LCP2014-4718 DRWNS: B061E CHKD: APPR: MBANKIS 2013/11/19 2014/05/12	QUALITY SYMBOLS	GENERAL TOLERANCES (UNLESS SPECIFIED)	DIMENSION STYLE	SCALE	DESIGN UNITS	THIRD ANGLE PROJECTION
	∇=0 ∇=0 ∇=0	4 PLACES ± mm 3 PLACES ± mm 2 PLACES ± 0.13 mm 1 PLACE ± 0.25 mm 0 PLACE ± mm	MM ONLY INCH	DRAWN BY: HAVERY DATE: 2010/11/16 CHECKED BY: DATE	4:1	METRIC
APPROVED BY: MBANKIS DATE: 2010/11/17		ANGULAR ±1/2° DRAFT WHERE APPLICABLE MUST REMAIN WITHIN DIMENSIONS		SHEET NO. 1 OF 3		

THIS DRAWING CONTAINS INFORMATION THAT IS PROPRIETARY TO MOLEX INCORPORATED AND SHOULD NOT BE USED WITHOUT WRITTEN PERMISSION

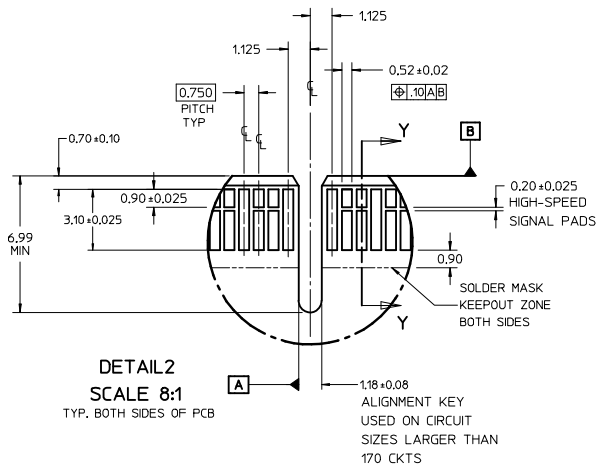
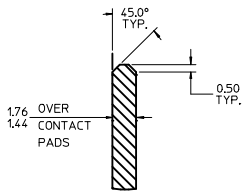
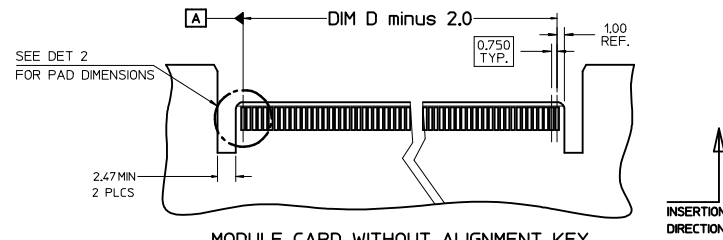
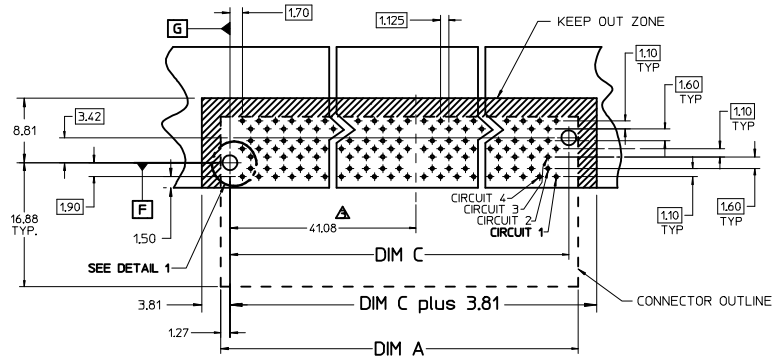
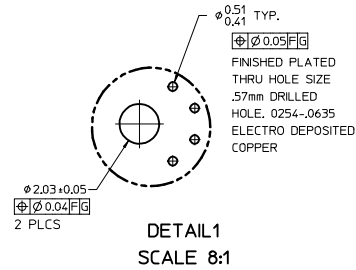

SEE SHEET 1 EC NO: UCP2014-4718 DRAWNS: SPOGIEL 2013/11/19 CHKD: APPR: MBANKIS 2014/05/12 REV: DESCRIPTION	QUALITY SYMBOLS ▽=0 ▽=0 ▽=0		GENERAL TOLERANCES (UNLESS SPECIFIED) DIMENSION STYLE MM ONLY		SCALE 4:1	DESIGN UNITS METRIC	THIRD ANGLE PROJECTION
	4 PLACES ± mm ± INCH 3 PLACES ± --- ± --- 2 PLACES ± 0.13 ± --- 1 PLACE ± 0.25 ± --- 0 PLACE ± --- ± ---		DRAWN BY DATE HAVERY 2010/11/16 CHECKED BY DATE		TITLE .75 COPLANAR CONNECTOR GENERAL SALES DRAWING		
	ANGULAR ± 1/2° DRAFT WHERE APPLICABLE MUST REMAIN WITHIN DIMENSIONS		APPROVED BY DATE MBANKIS 2010/11/17		MATERIAL NO. DOCUMENT NO. SEE CHART SD-76291-001		
			SIZE D THIS DRAWING CONTAINS INFORMATION THAT IS PROPRIETARY TO MOLEX INCORPORATED AND SHOULD NOT BE USED WITHOUT WRITTEN PERMISSION		SHEET NO. 2 OF 3		

PCB PIN-OUT ASSIGNMENTS

(TOP SIDE OF BOARD SHOWN)

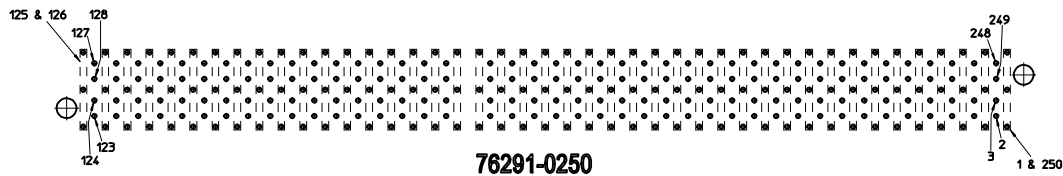
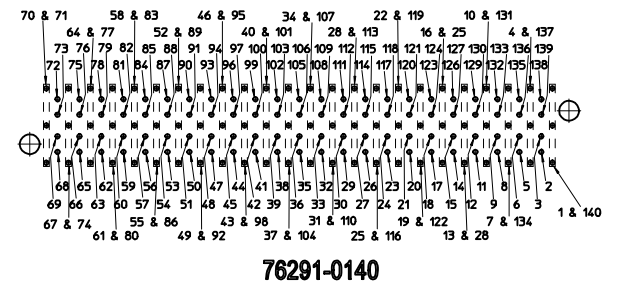
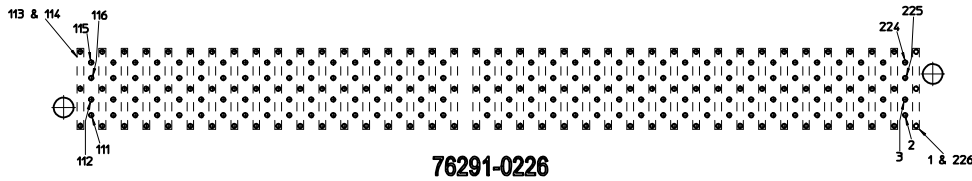
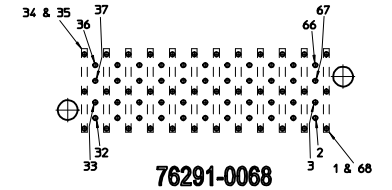
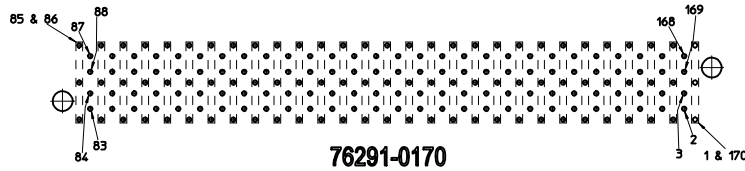
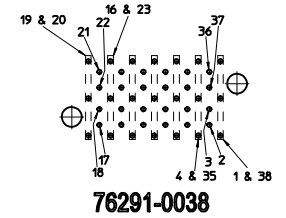
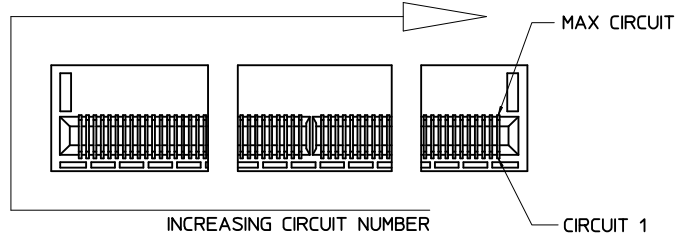

FRONT EDGE OF PCB

NOTES ON CIRCUIT DESIGNATIONS:

1. CIRCUIT 1 STARTS AT LOWER RIGHT HAND CORNER AND INCREASES TO THE LEFT ACROSS THE BOTTOM AND INCREASES TO THE RIGHT ACROSS THE TOP.
2. THERE IS NOT A 1:1 CORRESPONDENCE BETWEEN THE CIRCUIT NUMBER AND THE TAIL HOLE LOCATIONS. EACH GROUND HAS TWO CONTACTS AND THREE TAILS. THE BOXES AROUND THE THREE VERTICAL HOLES INDICATE THE UPPER AND LOWER GROUND CONTACTS SHARE THE THREE TAIL HOLE LOCATIONS.

SEE SHEET 1 EC NO: UCP2014-4718 DRWNSB01EL 2013/11/19 CHKD: APPROBANKIS 2014/05/12	QUALITY SYMBOLS	GENERAL TOLERANCES (UNLESS SPECIFIED)	DIMENSION STYLE	SCALE	DESIGN UNITS	THIRD ANGLE PROJECTION
	▽=0	4 PLACES ± mm INCH	MM ONLY	4:1	METRIC	
	▽=0	3 PLACES ± 0.13	DRAWN BY DATE	HAVERY 2010/11/16	TITLE	.75 COPLANAR CONNECTOR GENERAL SALES DRAWING
	▽=0	1 PLACE ± 0.25	CHECKED BY DATE		APPROVED BY DATE	
	0 PLACE	ANGULAR ±1/2°	MATERIAL NO.	SEE CHART	DOCUMENT NO.	SHEET NO.
		DRAFT WHERE APPLICABLE MUST REMAIN WITHIN DIMENSIONS			SD-76291-001	3 OF 3

molex

THIS DRAWING CONTAINS INFORMATION THAT IS PROPRIETARY TO MOLEX INCORPORATED AND SHOULD NOT BE USED WITHOUT WRITTEN PERMISSION