

断面図 (参考)

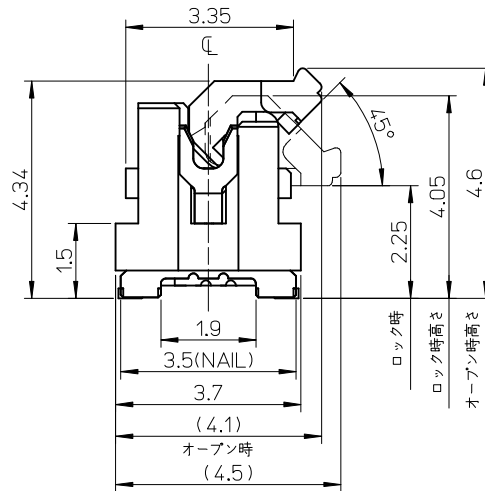

注記 NOTES

1. 使用材料 MATERIAL  
 ハウジング : 液晶ポリマー ガラス充填, UL94V-0(白)  
 HOUSING : LIQUID CRYSTAL POLYMER GLASS FILLED, UL94V-0 (WHITE)  
 アクチュエータ : ポリアミド 9T, ガラス充填, UL94V-0(茶)  
 ACTUATOR : POLYAMIDE 9T, GLASS FILLED, UL94V-0 (BROWN)  
 ターミナル : 銅合金(t=0.15)  
 TERMINAL : COPPER ALLOY  
 金具 : 銅合金(t=0.2)  
 FITTING NAIL : COPPER ALLOY
  2. めっき仕様 PLATING  
 ターミナル TERMINAL  
 コネクタ部 : 部分金めっき(0.1μm以上)  
 テール部 : 部分金めっき  
 下地 : ニッケルめっき(1.0μm以上)  
 CONTACT AREA : SEPARATED GOLD PLATING (0.1 MICROMETER MINIMUM)  
 SOLDER TAIL AREA : SEPARATED GOLD PLATING UNDERPLATE : NICKEL OVERALL  
 金具 FITTING NAIL  
 ニッケル下地めっき  
 銅めっき(1.0μm以上)  
 ニッケルめっき(1.0μm以上)  
 TIN(Sn) OVER NICKEL(Ni) PLATING.  
 TIN PLATING (1.0 MICROMETER MINIMUM)  
 NICKEL PLATING (1.0 MICROMETER MINIMUM)
  3. テールと金具を併せた平坦度は 0.1ミリメートル以下(リフロー前)  
 TAILS AND NAILS COPLANARITY TO BE 0.1 MAX. (BEFORE REFLOW)
  4. ELV及びRoHS適合品  
 ELV AND RoHS COMPLIANT
- △ R0.3は、FPC導体部にかからないこと。  
 R0.3 MUST NOT BE OVERLAPPED TO PATTERN OF FPC.

8	35.7	37.1	37.4	34.5	37.8	501951-7019	70
	30.7	32.1	32.4	29.5	32.8	501951-6019	60
	25.7	27.1	27.4	24.5	27.8	501951-5019	50
	23.2	24.6	24.9	22	25.3	501951-4519	45
	20.7	22.1	22.4	19.5	22.8	501951-4019	40
	16.7	18.1	18.4	15.5	18.8	501951-3219	32
	15.7	17.1	17.4	14.5	17.8	501951-3019	30
	12.7	14.1	14.4	11.5	14.8	501951-2419	24
	11.7	13.1	13.4	10.5	13.8	501951-2219	22
10.7	12.1	12.4	9.5	12.8	501951-2019	20	
F	E	D	C	B	A	MATERIAL NO.	CIRCUITS

REVISED EC NO.: J2015-1526 DRAWN: ISHII 2015/05/18 CHK: KAKAHASHI 2015/05/18 APPR: YNOGAWA 2015/05/20	GENERAL TOLERANCES (UNLESS SPECIFIED)			DIMENSION STYLE MM ONLY		SCALE 10:1	DESIGN UNITS METRIC	THIRD ANGLE PROJECTION
	0.25 UNDER	±0.03	DRAWN BY TRSUZUKI		DATE 2006/08/21	TITLE 0.5 FPC CONN. HSG ASSY EASY ON / STRAIGHT (GOLD)		
	0.25 OVER 0.5 UNDER	±0.05	CHECKED BY HIRATA		DATE 2006/08/21	molex		
	0.5 OVER 1.0 UNDER	±0.1	APPROVED BY MSASAO		DATE 2006/08/21			
	1.0 OVER 10 UNDER	±0.2	MATERIAL NO.		DOCUMENT NO.	SHEET NO.	1 OF 2	
10 OVER 30 UNDER	±0.25	SEE CHART		SD-501951-003				
30 OVER	±0.3	DRAFT WHERE APPLICABLE MUST REMAIN WITHIN DIMENSIONS		SIZE A3	THIS DRAWING CONTAINS INFORMATION THAT IS PROPRIETARY TO MOLEX INCORPORATED AND SHOULD NOT BE USED WITHOUT WRITTEN PERMISSION			

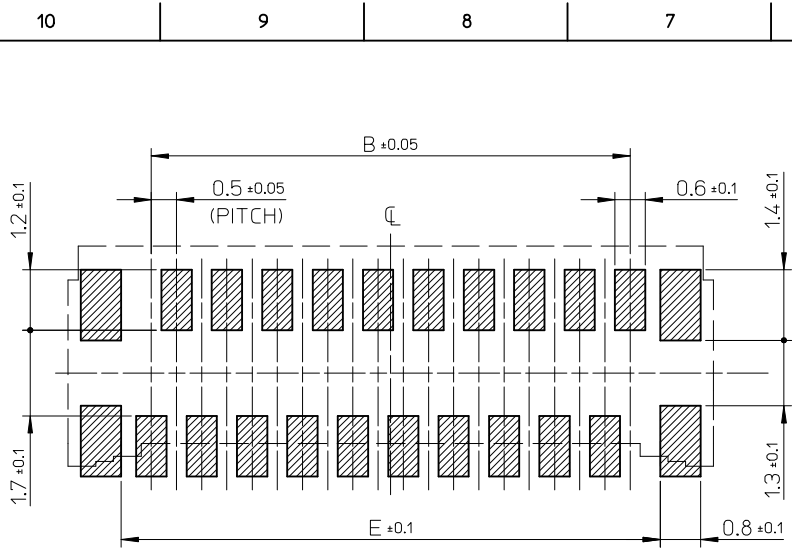

参考基板レイアウト (マウント面)  
P.C. BOARD PATTERN DIMENSION (REF.)  
(MOUNT AREA)

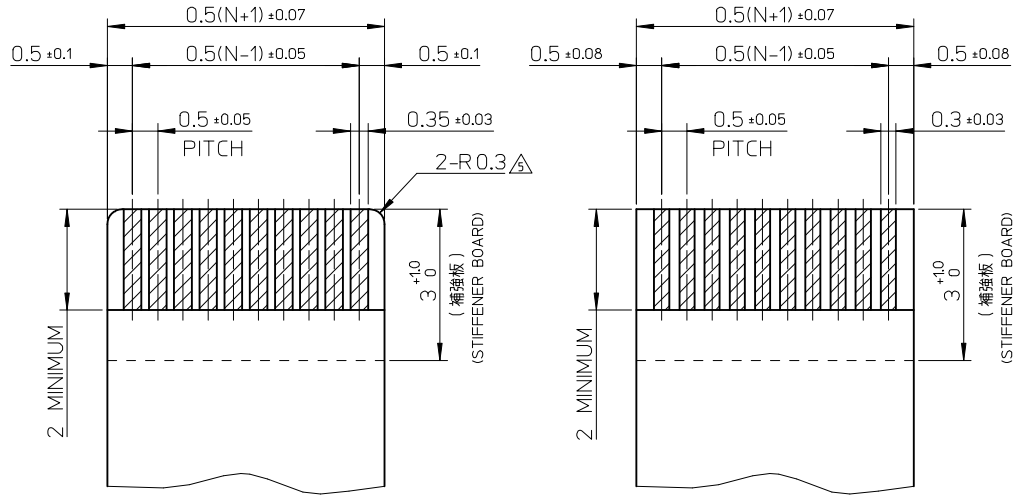

適合FPC推奨寸法  
APPLICABLE FPC  
RECOMMENDED DIMENSION  
(仕上がり厚さ: 0.3 ± 0.05)  
(THICKNESS: 0.3 ± 0.05)  
N: 極数  
N: CIRCUITS

適合FFC推奨寸法  
APPLICABLE FFC  
RECOMMENDED DIMENSION  
(仕上がり厚さ: 0.3 ± 0.05)  
(THICKNESS: 0.3 ± 0.05)  
N: 極数  
N: CIRCUITS

FPCについて ABOUT FPC

補強フィルム材質はポリイミドを推奨します。ベースフィルムは25μmを推奨します。  
接着剤は熱硬化接着剤を推奨します。  
尚、接着剤の接点部への付着は導通不良の原因になりますので、染み出しが無い様お願い致します。  
RECOMMENDED MATERIAL/THICKNESS.  
RECOMMENDED STIFFENER MATERIAL: POLYIMIDE  
RECOMMENDED BASE FILM THICKNESS: 25 MICROMETER  
RECOMMENDED ADHESIVE: THERMOSETTING ADHESIVE  
NOTE: PLEASE PUT APPROPRIATE AMOUNT OF ADHESIVE ON ADHEREND BECAUSE THERE IS A POSSIBILITY THAT THE EXTRA ADHESIVE CAUSES THE DEFECT IN ELECTRICAL CONTINUITY. THERE IS A POSSIBILITY THAT THE PRESCRIPT TEMPERATURE OF FFC IS SET TO SINGLE IT.

FPC/FFCについて ABOUT FPC/FFC

打ち抜き方向は導体側から補強板側を推奨します。  
導体部については軟箔銅35μmまたは50μmを推奨します。  
FFCに規定された定格温度がFFC単体前提である場合が御座います。  
コネクタと組み合わせての実使用において、接着層が劣化するなどの信頼性を満足できないケースを回避するため、実機での評価/確認をお願い致します。  
RECOMMENDED PUNCHING DIRECTION: FROM CONDUCTOR SIDE TO STIFFENER SIDE  
RECOMMENDED CONDUCTOR SPEC: SOFT COPPER FOIL  
RECOMMENDED CONDUCTOR THICKNESS: 35 MICROMETER OR 50 MICROMETER  
NOTE: WHEN ACTUALLY USING IT WITH CONNECTOR, PLEASE DO THE EVALUATION AND THE CONFIRMATION WITH AN ACTUAL EQUIPMENT TO EVADE THE CASE WHERE RELIABILITY CANNOT BE FILLED (THE ADHESIVE LINE OF FFC IS DETERIORATED ETC.)

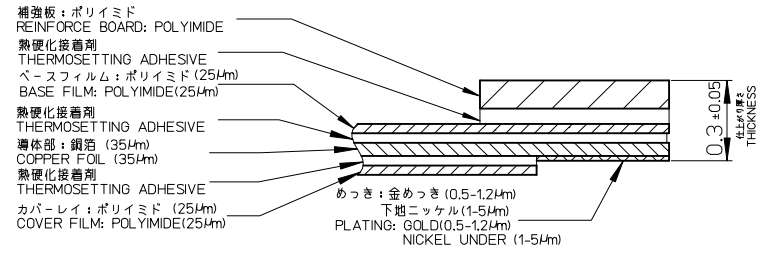

FPC構成推奨仕様  
STRUCTURE OF FPC

SEE SHEET 1 OF 2 EC NO: J2015-1526 DRAWN BY: DRWNAISHI 2015/05/18 CHECKED BY: CHKD:TAKAHASHI 2015/05/18 APPR: YNOGAWA 2015/05/20	GENERAL TOLERANCES (UNLESS SPECIFIED)		DIMENSION STYLE MM ONLY		SCALE ---	DESIGN UNITS METRIC	THIRD ANGLE PROJECTION
	0.25 UNDER	±0.03	DRAWN BY	DATE	TITLE		
	0.25 OVER 0.5 UNDER	±0.05	TRSUZUKI	2006/08/21	0.5 FPC CONN. HSG ASSY EASY ON / STRAIGHT (GOLD)		
	0.5 OVER 1.0 UNDER	±0.1	CHECKED BY	DATE	molex		
1.0 OVER 10 UNDER	±0.2	HIRATA	2006/08/21	APPROVED BY	DATE	MATERIAL NO.	DOCUMENT NO.
10 OVER 30 UNDER	±0.25	MSASAO	2006/08/21	SEE SHEET 1 OF 2		SD-501951-003	SHEET NO. 2 OF 2
30 OVER	±0.3	DRAFT WHERE APPLICABLE MUST REMAIN WITHIN DIMENSIONS		SIZE A3	THIS DRAWING CONTAINS INFORMATION THAT IS PROPRIETARY TO MOLEX INCORPORATED AND SHOULD NOT BE USED WITHOUT WRITTEN PERMISSION		

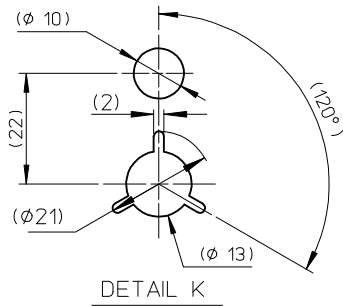
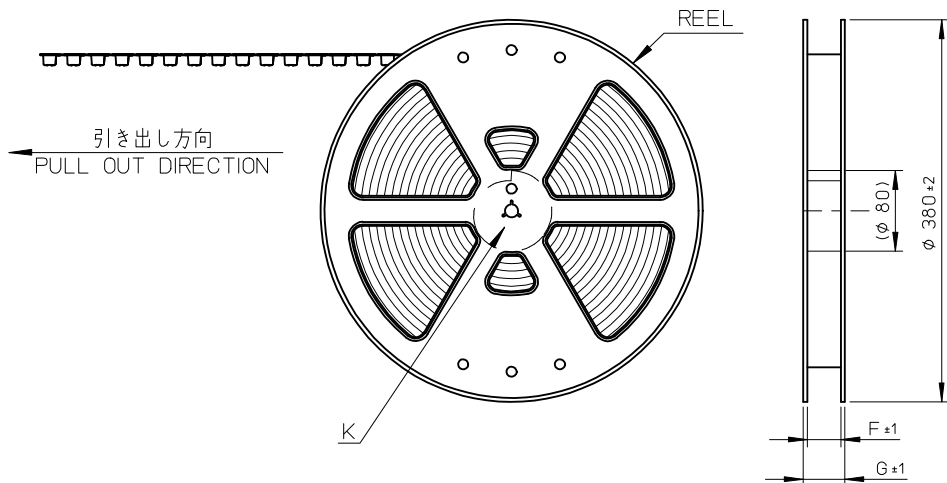

NOTES

- 製品詳細寸法については図面 SD-501951-003を参照下さい。  
FOR DIMENSIONS OF PRODUCT, REFER TO SD-501951-003.
- 梱包数量 : 2000個/リール  
NUMBER OF CONNECTORS : 2000PIECES/REEL
- リードテープ長さ  
LEAD TAPE LENGTH

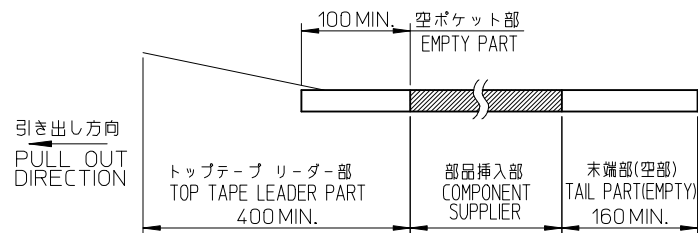

- 材料 MATERIAL  
 キャリアテープ : ポリプロピレン  
 CARRIER TAPE : POLYPROPYLENE  
 トップテープ : ポリエチレンテレフタレート, ポリエチレン  
 TOP TAPE : POLYETHYLENE TEREPHTHALATE , POLYETHYLENE  
 リール : ポリスチレン<リサイクル材を含む>  
 REEL : POLYSTYRENE <RECYCLE MATERIAL CONTAINED>
- ELV及びRoHS適合品 ELV AND RoHS COMPLIANT

REVISED EC NO.: J2014-0085 DRWN: KONDO 2013/07/17 CHKD: TAKAHASHI 2013/07/17 APPR: YNOGAWA 2013/07/17	GENERAL TOLERANCES (UNLESS SPECIFIED)		DIMENSION STYLE MM ONLY		SCALE ---	DESIGN UNITS METRIC	THIRD ANGLE PROJECTION
	10 UNDER	± 0.2	DRAWN BY TRSUZUKI	DATE 2006/09/05	TITLE 0.5 FPC CONN. HSG ASSY E/O STRAIGHT EMBSTP PKG (GOLD)		
	10 OVER 30 UNDER	± 0.25	CHECKED BY HHRATA	DATE 2006/09/05			
	30 OVER	± 0.3	APPROVED BY MSASAO	DATE 2006/09/05	<b>molex</b> DOCUMENT NO. SD-501951-004 SHEET NO. 1 OF 2		
ANGULAR ± 1 °		MATERIAL NO. SEE CHART					
DRAFT WHERE APPLICABLE MUST REMAIN WITHIN DIMENSIONS		SIZE A3		THIS DRAWING CONTAINS INFORMATION THAT IS PROPRIETARY TO MOLEX INCORPORATED AND SHOULD NOT BE USED WITHOUT WRITTEN PERMISSION			

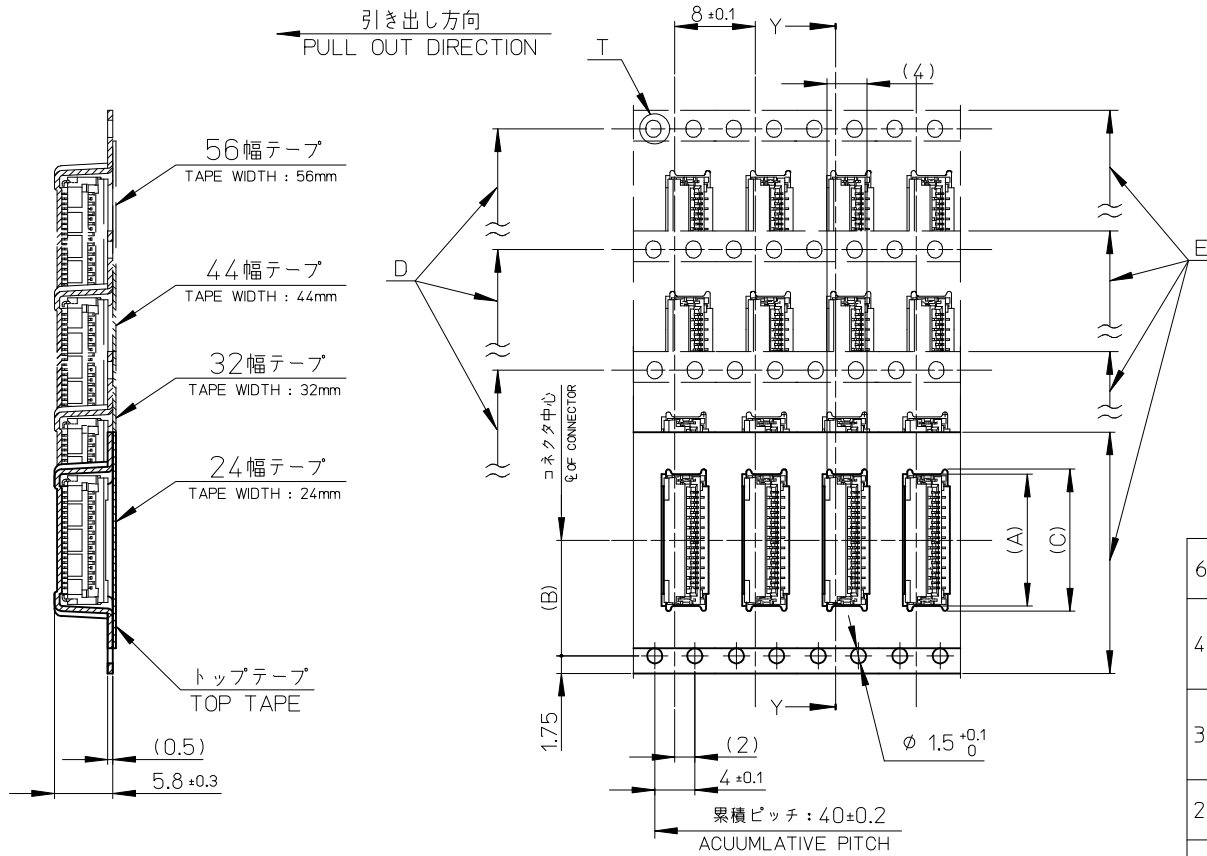

断面 Y-Y  
SECTION Y-Y

REVISED EC NO: J2014-0085 DR: WNKONO 2013/07/17 CHKD: TAKAHASHI 2013/07/17 APPR: YNOGAWA 2013/07/17	GENERAL TOLERANCES (UNLESS SPECIFIED)		DIMENSION STYLE MM ONLY		SCALE ---	DESIGN UNITS METRIC	THIRD ANGLE PROJECTION		
	10 UNDER	±0.2	DRAWN BY TRSUZUKI	DATE 2006/09/05	TITLE 0.5 FPC CONN. HSG ASSY E/O STRAIGHT EMBSTP PKG (GOLD)				
	10 OVER 30 UNDER	±0.25	CHECKED BY HHRATA	DATE 2006/09/05					
	30 OVER	±0.3	APPROVED BY MSASAO	DATE 2006/09/05					
ANGULAR	±1 °	DRAFT WHERE APPLICABLE MUST REMAIN WITHIN DIMENSIONS		MATERIAL NO. SEE CHART	DOCUMENT NO. SD-501951-004	SHEET NO. 2 OF 2			
REV	THIS DRAWING CONTAINS INFORMATION THAT IS PROPRIETARY TO MOLEX INCORPORATED AND SHOULD NOT BE USED WITHOUT WRITTEN PERMISSION							SIZE A3	