

LEADFREE CONVERTER. EC NO: UCP2013-1898 DRAWN: MPOFF 2012/11/12 CHKD: MWOLFE 2012/11/12 APPR: SMILLER 2012/12/21	QUALITY SYMBOLS 	GENERAL TOLERANCES (UNLESS SPECIFIED)		DIMENSION STYLE MM ONLY	SCALE 4:1	DESIGN UNITS METRIC	THIRD ANGLE PROJECTION		
		4 PLACES ± --- ± --- 3 PLACES ± --- ± --- 2 PLACES ± 0.13 ± --- 1 PLACE ± 0.25 ± --- 0 PLACE ± ±	mm INCH ± --- ± --- ± --- ± --- ± --- ± --- ± --- ± ---	DRAWN BY JLAURX	DATE 2/21/05	TITLE I-TRAC BACKPLANE HEADER GUIDE RIGHT ASSEMBLY SALES DRAWING			
		ANGULAR ± 1/2°		CHECKED BY BPISZCZOR	DATE 6/02/06	DOCUMENT NO. SD-75705-004			
		DRAFT WHERE APPLICABLE MUST REMAIN WITHIN DIMENSIONS		APPROVED BY CBIXLER	DATE 6/02/06	SHEET NO. 1 OF 4			

THIS DRAWING CONTAINS INFORMATION THAT IS PROPRIETARY TO MOLEX INCORPORATED AND SHOULD NOT BE USED WITHOUT WRITTEN PERMISSION

75705-****

MODULE TYPE -- TAIL PLATING TYPE
 GUIDE RIGHT -- TIN ONLY = 4 (PREVIOUSLY TIN/LEAD)
 GUIDE RIGHT -- TIN ONLY = 5
 GUIDE RIGHT W/END -- TIN ONLY = 8 (PREVIOUSLY TIN/LEAD)
 GUIDE RIGHT W/END -- TIN ONLY = 9

KEY ORIENTATION

- 0 = NO KEY
- 1 = A
- 2 = B
- 3 = C
- 4 = D
- 5 = E
- 6 = F
- 7 = G
- 8 = H

PIN LENGTH (P)

- 2 = 3.90 - 30 GOLD
- 3 = 4.70 - 30 GOLD
- 4 = 5.70 - 30 GOLD
- 5 = 4.70 & 5.70 - 30 GOLD STAGGERED
- 6 = 3.90 - 10 GOLD
- 7 = 4.70 - 10 GOLD
- 8 = 5.70 - 10 GOLD
- 9 = 4.70 & 5.70 - 10 GOLD STAGGERED

OF COLUMNS

- 5 = 5 COL
- 6 = 6 COL
- 8 = 8 COL
- 1 = 10 COL

MATERIAL NUMBER	# OF COLUMNS	DIM "A"	DIM "B"
75705-#5**	5	24.8	14.80
75705-#6**	6	28.5	18.50
75705-#8**	8	35.9	25.90
75705-#1**	10	43.3	33.30

GUIDE RIGHT STYLE

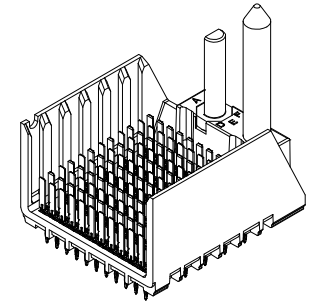

MATERIAL NUMBER	# OF COLUMNS	DIM "A"	DIM "B"
75705-#5**	5	26.1	14.80
75705-#6**	6	29.8	18.50
75705-#8**	8	37.2	25.90
75705-#1**	10	44.6	33.30

GUIDE RIGHT W/END STYLE

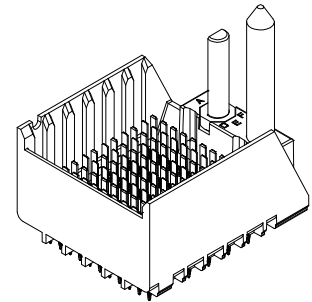

NOTES:

1. MATERIALS: HOUSING - LIQUID CRYSTAL POLYMER (LCP)
GLASS-FILLED, UL94V-0
TERMINALS - HIGH PERFORMANCE COPPER ALLOY
2. FINISH: 10 MICROINCH MINIMUM GOLD OR 30 MICROINCH MINIMUM GOLD
IN CONTACT AREA. SELECTIVE MATTE TIN ON PCB TAILS,
NICKEL OVERALL.
3. REFER TO MOLEX PRODUCT SPECIFICATION PS-75710-999
FOR PERFORMANCE SPECIFICATIONS.
4. FOR MIXED CONTACT MATING LENGTHS, CONSULT MOLEX
FOR AVAILABILITY.
5. THIS PART CONFORMS TO CLASS B REQUIREMENTS OF
MOLEX COSMETIC SPEC PS-45499-002.
6. PACKAGE PER: PK-70873-587.
7. GUIDED PARTS TO BE SHIPPED WITH 2-56 UNC B SCREW P/N 73774-1000.
8. FOR GROUNDED GUIDE PINS USE DIA 3.56+/-0.08 (PTH)
DIA 3.66 (DRILL), AND DIA 6.5 (PAD).
9. REFER TO PCB ROUTING GUIDE FOR ANTIPAD AND ROUTING RECOMMENDATIONS.

SEE SHEET 1 EC NO: UCP2013-1898 DRWN:MP0FF 2012/11/12 CHKD:MMOLFE 2012/11/12 APPR:SMILLER 2012/12/21	QUALITY SYMBOLS ▽=0 ▽=0 ▽=0	GENERAL TOLERANCES (UNLESS SPECIFIED)		DIMENSION STYLE MM ONLY		SCALE 4:1	DESIGN UNITS METRIC	THIRD ANGLE PROJECTION																	
		<table border="1"> <tr> <th></th> <th>mm</th> <th>INCH</th> </tr> <tr> <td>4 PLACES</td> <td>± .005</td> <td>± .0004</td> </tr> <tr> <td>3 PLACES</td> <td>± .005</td> <td>± .0004</td> </tr> <tr> <td>2 PLACES</td> <td>± 0.13</td> <td>± .005</td> </tr> <tr> <td>1 PLACE</td> <td>± 0.25</td> <td>± .010</td> </tr> <tr> <td>0 PLACE</td> <td>±</td> <td>±</td> </tr> </table>			mm	INCH	4 PLACES	± .005	± .0004	3 PLACES	± .005	± .0004	2 PLACES	± 0.13	± .005	1 PLACE	± 0.25	± .010	0 PLACE	±	±	DRAWN BY JLAURX DATE 2/21/05		TITLE I-TRAC BACKPLANE HEADER GUIDE RIGHT ASSEMBLY SALES DRAWING	
			mm	INCH																					
		4 PLACES	± .005	± .0004																					
3 PLACES	± .005	± .0004																							
2 PLACES	± 0.13	± .005																							
1 PLACE	± 0.25	± .010																							
0 PLACE	±	±																							
DRAFT WHERE APPLICABLE MUST REMAIN WITHIN DIMENSIONS		APPROVED BY CBIXLER DATE 6/02/06		DOCUMENT NO. SD-75705-004																					
		ANGULAR ±1/2°		SIZE C		SHEET NO. 2 OF 4		THIS DRAWING CONTAINS INFORMATION THAT IS PROPRIETARY TO MOLEX INCORPORATED AND SHOULD NOT BE USED WITHOUT WRITTEN PERMISSION																	

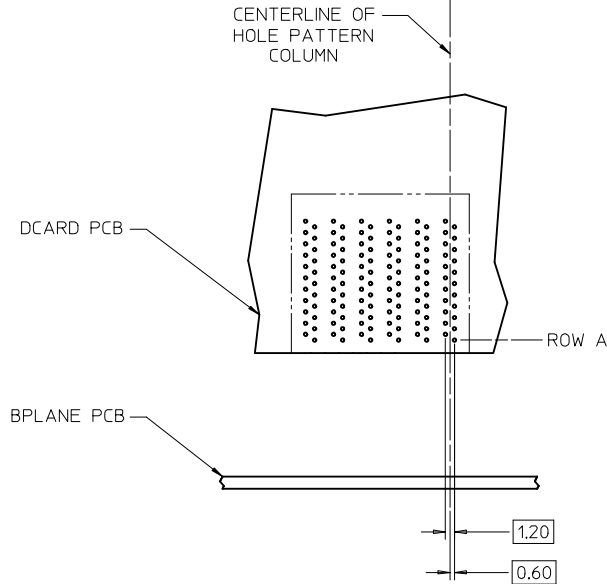
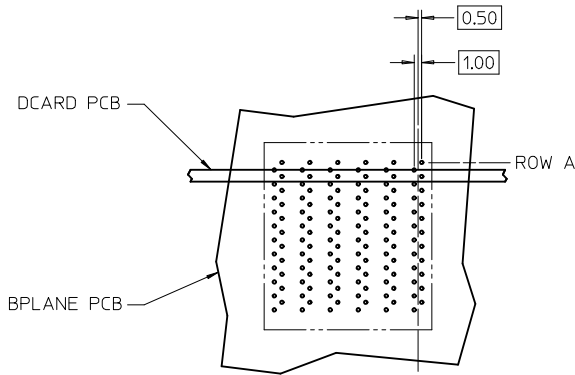

I-TRAC 11 ROW BOARD RELATIONSHIPS

SCALE 2:1

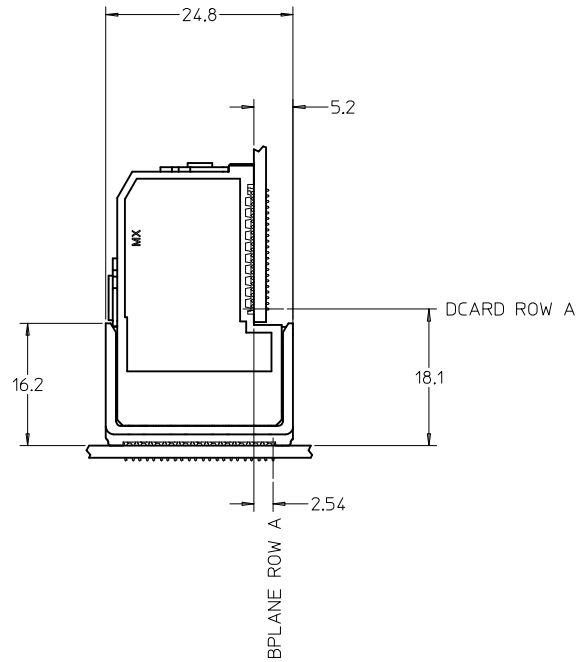

SEE SHEET 1 EC NO: UCP2013-1898 DRWIN:POFF 2012/11/12 CHKD:MMOLFE 2012/11/12 APPR:SMILLER 2012/12/21	QUALITY SYMBOLS ▽=0 ▽=0 ▽=0	GENERAL TOLERANCES (UNLESS SPECIFIED) <table border="1"> <tr> <th></th> <th>mm</th> <th>INCH</th> </tr> <tr> <td>4 PLACES</td> <td>± ---</td> <td>± ---</td> </tr> <tr> <td>3 PLACES</td> <td>± ---</td> <td>± ---</td> </tr> <tr> <td>2 PLACES</td> <td>± 0.13</td> <td>± ---</td> </tr> <tr> <td>1 PLACE</td> <td>± 0.25</td> <td>± ---</td> </tr> <tr> <td>0 PLACE</td> <td>±</td> <td>±</td> </tr> </table>		mm	INCH	4 PLACES	± ---	± ---	3 PLACES	± ---	± ---	2 PLACES	± 0.13	± ---	1 PLACE	± 0.25	± ---	0 PLACE	±	±	DIMENSION STYLE MM ONLY DRAWN BY DATE JLAURX 2/21/05 CHECKED BY DATE BPISZCZOR 6/02/06 APPROVED BY DATE CBIXLER 6/02/06	SCALE 4:1 DESIGN UNITS METRIC THIRD ANGLE PROJECTION	TITLE I-TRAC BACKPLANE HEADER GUIDE RIGHT ASSEMBLY SALES DRAWING molex DOCUMENT NO. SD-75705-004 SHEET NO. 3 OF 4
		mm	INCH																				
	4 PLACES	± ---	± ---																				
	3 PLACES	± ---	± ---																				
2 PLACES	± 0.13	± ---																					
1 PLACE	± 0.25	± ---																					
0 PLACE	±	±																					
MATERIAL NO. SEE TABLE	ANGULAR ±1/2° DRAFT WHERE APPLICABLE MUST REMAIN WITHIN DIMENSIONS	THIS DRAWING CONTAINS INFORMATION THAT IS PROPRIETARY TO MOLEX INCORPORATED AND SHOULD NOT BE USED WITHOUT WRITTEN PERMISSION																					

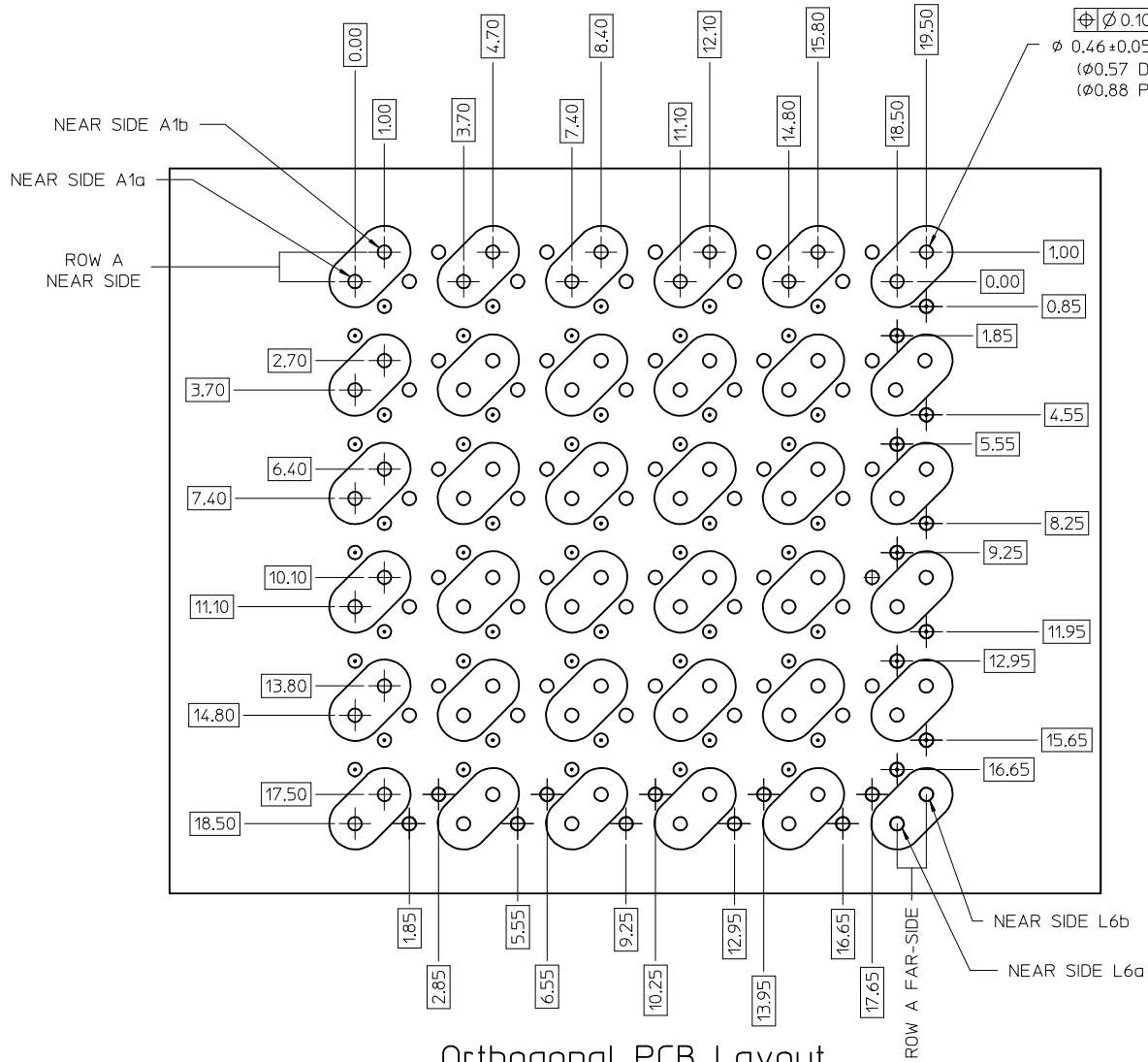

$\varnothing 0.10$
 $\varnothing 0.46 \pm 0.05$ PTH
 ($\varnothing 0.57$ DRILL)
 ($\varnothing 0.88$ PAD)

ORTHO PIN MAPPING					
OPTION 90 (NEAR SIDE - FAR SIDE)					
A1b-L6b	A2b-J6b	A3b-G6b	A4b-E6b	A5b-C6b	A6b-A6b
A1a-L6a	A2a-J6a	A3a-G6a	A4a-E6a	A5a-C6a	A6a-A6a
C1b-L5b	C2b-J5b	C3b-G5b	C4b-E5b	C5b-C5b	C6b-A5b
C1a-L5a	C2a-J5a	C3a-G5a	C4a-E5a	C5a-C5a	C6a-A5a
E1b-L4b	E2b-J4b	E3b-G4b	E4b-E4b	E5b-C4b	E6b-A4b
E1a-L4a	E2a-J4a	E3a-G4a	E4a-E4a	E5a-C4a	E6a-A4a
G1b-L3b	G2b-J3b	G3b-G3b	G4b-E3b	G5b-C3b	G6b-A3b
G1a-L3a	G2a-J3a	G3a-G3a	G4a-E3a	G5a-C3a	G6a-A3a
J1b-L2b	J2b-J2b	J3b-G2b	J4b-E2b	J5b-C2b	J6b-A2b
J1a-L2a	J2a-J2a	J3a-G2a	J4a-E2a	J5a-C2a	J6a-A2a
L1b-L1b	L2b-J1b	L3b-G1b	L4b-E1b	L5b-C1b	L6b-A1b
L1a-L1a	L2a-J1a	L3a-G1a	L4a-E1a	L5a-C1a	L6a-A1a

ORTHO PIN MAPPING					
OPTION 270 (NEAR SIDE - FAR SIDE)					
A1b-A1a	A2b-C1a	A3b-E1a	A4b-G1a	A5b-J1a	A6b-L1a
A1a-A1b	A2a-C1b	A3a-E1b	A4a-G1b	A5a-J1b	A6a-L1b
C1b-A2a	C2b-C2a	C3b-E2a	C4b-G2a	C5b-J2a	C6b-L2a
C1a-A2b	C2a-C2b	C3a-E2b	C4a-G2b	C5a-J2b	C6a-L2b
E1b-A3a	E2b-C3a	E3b-E3a	E4b-G3a	E5b-J3a	E6b-L3a
E1a-A3b	E2a-C3b	E3a-E3b	E4a-G3b	E5a-J3b	E6a-L3b
G1b-A4a	G2b-C4a	G3b-E4a	G4b-G4a	G5b-J4a	G6b-L4a
G1a-A4b	G2a-C4b	G3a-E4b	G4a-G4b	G5a-J4b	G6a-L4b
J1b-A5a	J2b-C5a	J3b-E5a	J4b-G5a	J5b-J5a	J6b-L5a
J1a-A5b	J2a-C5b	J3a-E5b	J4a-G5b	J5a-J5b	J6a-L5b
L1b-A6a	L2b-C6a	L3b-E6a	L4b-G6a	L5b-J6a	L6b-L6a
L1a-A6b	L2a-C6b	L3a-E6b	L4a-G6b	L5a-J6b	L6a-L6b

Orthogonal PCB Layout

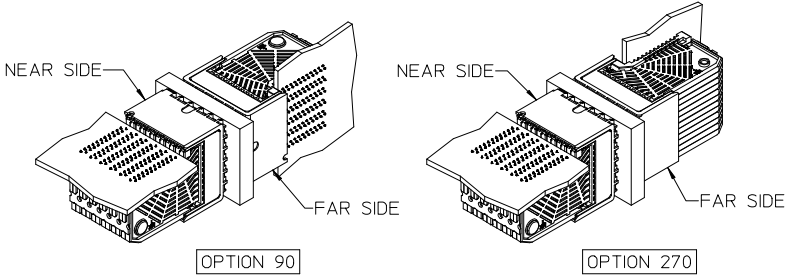

- NOTES:
- SIGNAL PAIRS (SHARED VIAS)
 - NEAR SIDE GROUNDS
 - FAR SIDE GROUNDS

SEE SHEET 1 EC NO: UCP2013-1898 DRWN:MP0FF 2012/11/12 CHKD:HWLFE 2012/11/12 APPR:SMILLER 2012/12/21	QUALITY SYMBOLS	GENERAL TOLERANCES (UNLESS SPECIFIED)	DIMENSION STYLE MM ONLY	SCALE 4:1	DESIGN UNITS METRIC	THIRD ANGLE PROJECTION
	$\nabla = \varnothing$	mm INCH	DRAWN BY JLAURX	DATE 2/21/05	TITLE I-TRAC BACKPLANE HEADER GUIDE RIGHT ASSEMBLY SALES DRAWING	
	$\nabla = \varnothing$	4 PLACES \pm --- \pm ---	CHECKED BY BPISZCZOR	DATE 6/02/06	molex DOCUMENT NO. SD-75705-004	
	$\nabla = \varnothing$	3 PLACES \pm --- \pm ---	APPROVED BY CBIXLER	DATE 6/02/06		
		2 PLACES ± 0.13 \pm ---	MATERIAL NO.		THIS DRAWING CONTAINS INFORMATION THAT IS PROPRIETARY TO MOLEX INCORPORATED AND SHOULD NOT BE USED WITHOUT WRITTEN PERMISSION	
	1 PLACE ± 0.25 \pm ---	DRAFT WHERE APPLICABLE MUST REMAIN WITHIN DIMENSIONS				
	0 PLACE \pm \pm	SIZE C				