

76015-****

MODULE TYPE -- TAIL PLATING TYPE
 UNGUIDED -- TIN ONLY = 0 (PREVIOUSLY TIN/LEAD)
 UNGUIDED -- TIN ONLY = 1

OF COLUMNS
 4 = 4 COL
 6 = 6 COL
 1 = 10 COL

PART STYLE
 0 = OPEN ENDS
 1 = LEFT END WALL
 2 = DUAL END WALL
 3 = RIGHT END WALL

PIN LENGTH (P)
 2 = 3.90 - 30 GOLD
 3 = 4.70 - 30 GOLD
 4 = 5.70 - 30 GOLD
 5 = 4.70 & 5.70 - 30 GOLD STAGGERED
 6 = 3.90 - 10 GOLD
 7 = 4.70 - 10 GOLD
 8 = 5.70 - 10 GOLD
 9 = 4.70 & 5.70 - 10 GOLD STAGGERED

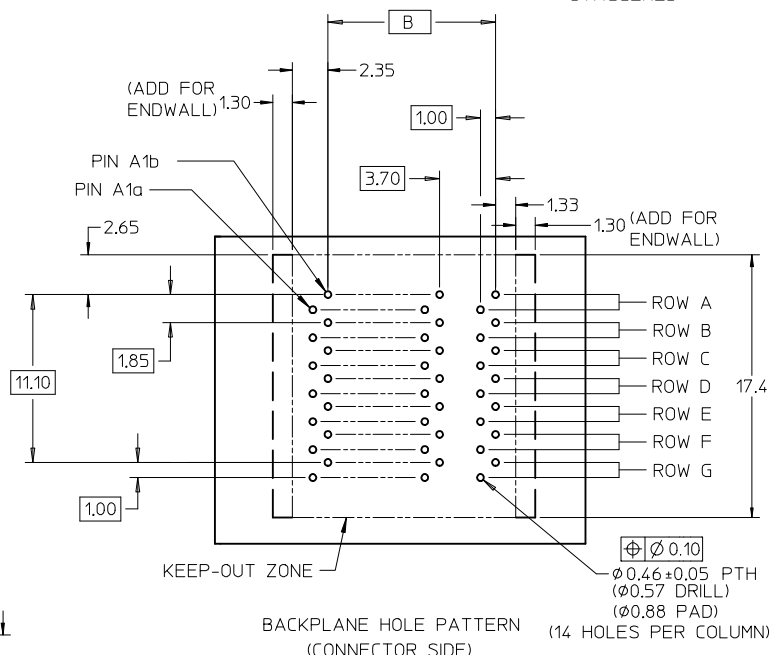

NOTES:

1. MATERIALS: HOUSING - LIQUID CRYSTAL POLYMER (LCP) GLASS-FILLED, UL94V-0
 TERMINALS - HIGH PERFORMANCE COPPER ALLOY
2. FINISH: 10 MICROINCH MINIMUM GOLD OR 30 MICROINCH MINIMUM GOLD IN CONTACT AREA. SELECTIVE MATTE TIN ON PCB TAILS, NICKEL OVERALL.
3. REFER TO MOLEX PRODUCT SPECIFICATION PS-75710-999 FOR PERFORMANCE SPECIFICATIONS.
4. FOR MIXED CONTACT MATING LENGTHS, CONSULT MOLEX FOR AVAILABILITY.
5. THIS PART CONFORMS TO CLASS B REQUIREMENTS OF MOLEX COSMETIC SPEC PS-45499-002
6. PACKAGE PER: PK-70873-802.
7. REFER TO PCB ROUTING GUIDE FOR ANTIPAD AND ROUTING RECOMMENDATIONS.

LEADFREE CONVERTER. EC NO: UCP2013-1898 TDR:WMP/POFF 2012/11/12 CHKD:MMOLFE 2012/11/12 APPR:SMILLER 2012/12/21	QUALITY SYMBOLS	DESCRIPTION
	REVISION	DESCRIPTION

GENERAL TOLERANCES (UNLESS SPECIFIED)	
mm	INCH
4 PLACES ± 0.13	± 0.005
3 PLACES ± 0.25	± 0.010
2 PLACES ± 0.25	± 0.010
1 PLACE ± 0.25	± 0.010
0 PLACE ±	±
ANGULAR ±1/2°	
DRAFT WHERE APPLICABLE MUST REMAIN WITHIN DIMENSIONS	

DIMENSION STYLE	
MM ONLY	
DRAWN BY	DATE
BPISZCZOR	2007/01/25
CHECKED BY	DATE
JLAURX	2007/02/06
APPROVED BY	DATE
CBIXLER	2007/02/06
MATERIAL NO.	
SEE TABLE	
SIZE	C

SCALE	5:1
DESIGN UNITS	METRIC
THIRD ANGLE PROJECTION	☉
I-TRAC BACKPLANE 7 ROW UNGUIDED ASSEMBLY SALES DRAWING	
molex	
DOCUMENT NO.	SD-76015-001
SHEET NO.	1 OF 4
THIS DRAWING CONTAINS INFORMATION THAT IS PROPRIETARY TO MOLEX. INCORPORATED AND SHOULD NOT BE USED WITHOUT WRITTEN PERMISSION	

MATERIAL NUMBER	# OF COLUMNS	DIM "A"	DIM "B"
76015-*42*	4	17.3	11.10
76015-*62*	6	24.7	18.50
76015-*12*	10	39.5	33.30

DUAL END STYLE

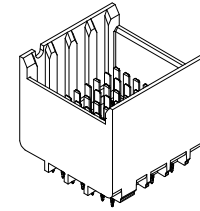

MATERIAL NUMBER	# OF COLUMNS	DIM "A"	DIM "B"
76015-*41*	4	16.0	11.10
76015-*61*	6	23.4	18.50
76015-*11*	10	38.2	33.30

LEFT END STYLE

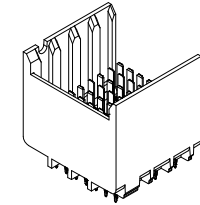

MATERIAL NUMBER	# OF COLUMNS	DIM "A"	DIM "B"
76015-*43*	4	16.0	11.10
76015-*63*	6	23.4	18.50
76015-*13*	10	38.2	33.30

RIGHT END STYLE

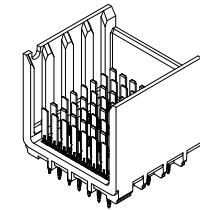

MATERIAL NUMBER	# OF COLUMNS	DIM "A"	DIM "B"
76015-*40*	4	14.7	11.10
76015-*60*	6	22.1	18.50
76015-*10*	10	36.9	33.30

OPEN END STYLE

NOTCH DESIGNATES
ROW A

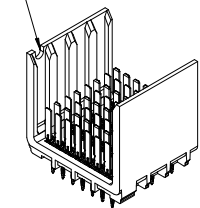

SEE SHEET 1 EC NO: UCP2013-1898 TIDRW:MP0FF 2012/11/12 CHKD:MMOLFE 2012/11/12 APPR:SMILLER 2012/12/21	QUALITY SYMBOLS 	GENERAL TOLERANCES (UNLESS SPECIFIED)		DIMENSION STYLE MM ONLY		SCALE 4:1	DESIGN UNITS METRIC	THIRD ANGLE PROJECTION		
		4 PLACES	± ---	± ---	DRAWN BY BPISZCZOR	DATE 2007/01/25	TITLE I-TRAC BACKPLANE 7 ROW UNGUIDED ASSEMBLY SALES DRAWING DOCUMENT NO. SD-76015-001			
		3 PLACES	± ---	± ---	CHECKED BY JLAURX	DATE 2007/02/06				
		2 PLACES	± 0.13	± ---	APPROVED BY CBIXLER	DATE 2007/02/06				
1 PLACE	± 0.25	± ---	MATERIAL NO. SEE TABLE							
0 PLACE	±	±	ANGULAR ±1/2°		SHEET NO. 2 OF 4					
DRAFT WHERE APPLICABLE MUST REMAIN WITHIN DIMENSIONS				THIS DRAWING CONTAINS INFORMATION THAT IS PROPRIETARY TO MOLEX INCORPORATED AND SHOULD NOT BE USED WITHOUT WRITTEN PERMISSION						

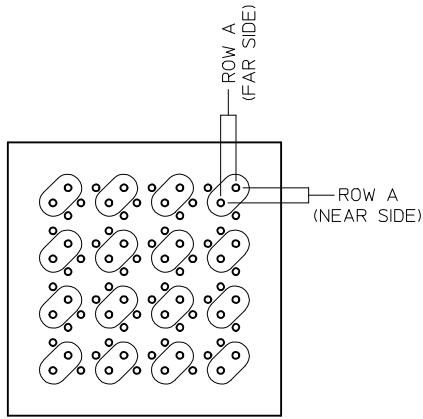

ORTHOGONAL MIDPLANE HOLE PATTERN
(16 SIGNAL PAIRS SHARE VIAS)

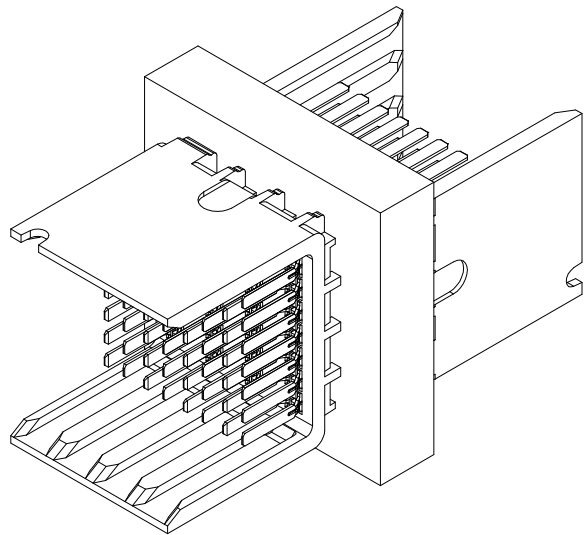

16 PAIR ORTHOGONAL MIDPLANE NODE
(USES TWO 4 COLUMN 7 ROW HEADERS)

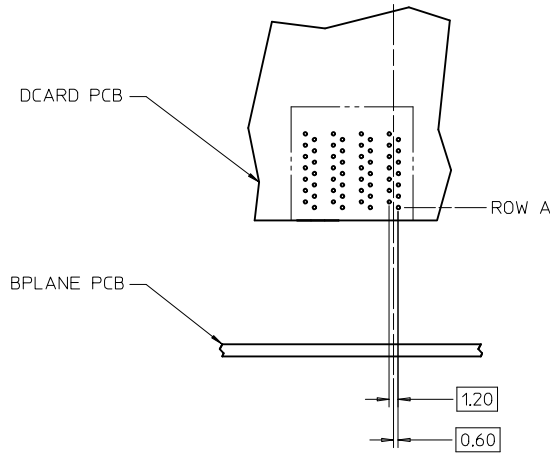
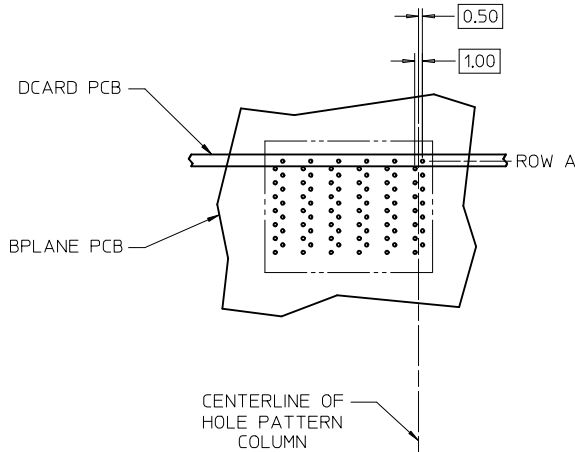

7 ROW I-TRAC
BOARD RELATIONSHIPS

SCALE 2:1

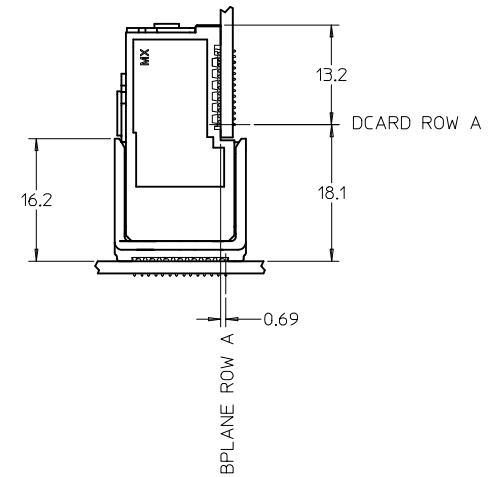

SEE SHEET 1 EC NO: UCP2013-1898 TIDRW:MPOFF 2012/11/12 CHKD:MWLF 2012/11/12 APPR:SMILLER 2012/12/21	QUALITY SYMBOLS ∇=0 ∇=0 ∇=0	GENERAL TOLERANCES (UNLESS SPECIFIED)		DIMENSION STYLE MM ONLY	SCALE 4:1	DESIGN UNITS METRIC	THIRD ANGLE PROJECTION	
		4 PLACES ± --- ± ---	DRAWN BY BPISZCZOR	DATE 2007/01/25	TITLE I-TRAC BACKPLANE 7 ROW UNGUIDED ASSEMBLY SALES DRAWING			
		3 PLACES ± --- ± ---	CHECKED BY JLAURX	DATE 2007/02/06	DOCUMENT NO. SD-76015-001			
		2 PLACES ± 0.13 ± ---	APPROVED BY CBIXLER	DATE 2007/02/06				
1 PLACE ± 0.25 ± ---	ANGULAR ±1/2°		MATERIAL NO. SEE TABLE		THIS DRAWING CONTAINS INFORMATION THAT IS PROPRIETARY TO MOLEX INCORPORATED AND SHOULD NOT BE USED WITHOUT WRITTEN PERMISSION			
0 PLACE ± ±	DRAFT WHERE APPLICABLE MUST REMAIN WITHIN DIMENSIONS		SIZE C					

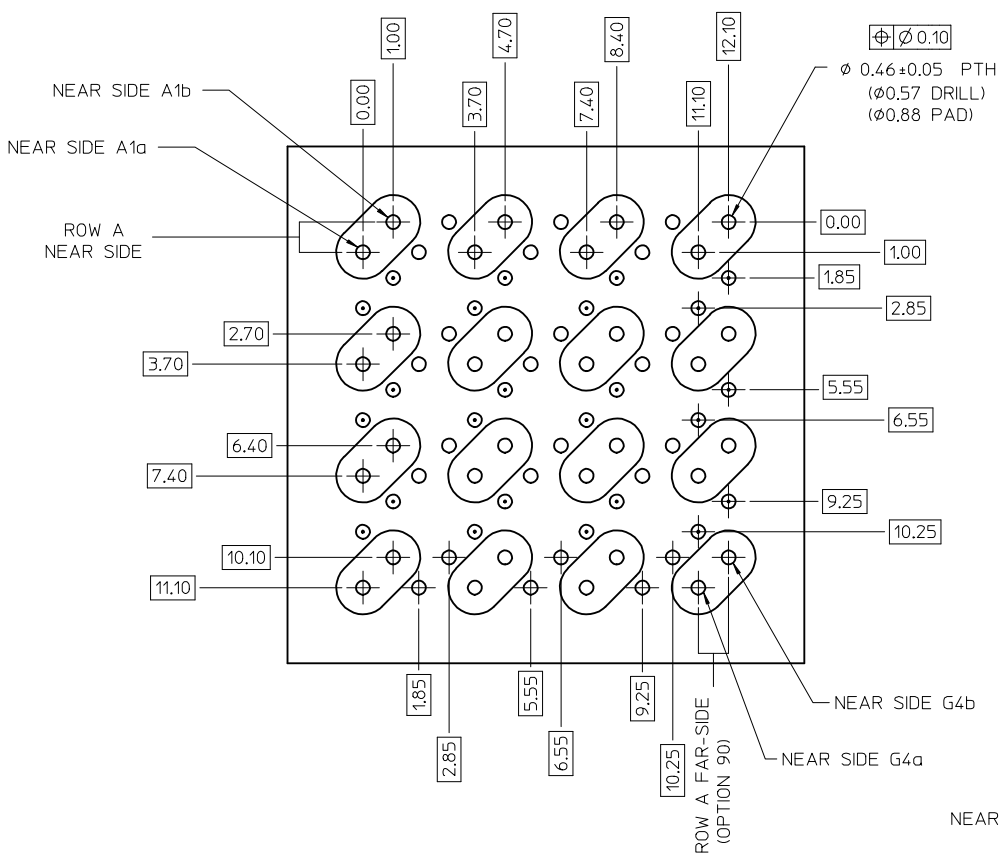

Orthogonal PCB Layout

ORTHO PIN MAPPING			
OPTION 90 (NEAR SIDE - FAR SIDE)			
A1b-G4b	A2b-E4b	A3b-C4b	A4b-A4b
A1a-G4a	A2a-E4a	A3a-C4a	A4a-A4a
C1b-G3b	C2b-E3b	C3b-C3b	C4b-A3b
C1a-G3a	C2a-E3a	C3a-C3a	C4a-A3a
E1b-G2b	E2b-E2b	E3b-C2b	E4b-A2b
E1a-G2a	E2a-E2a	E3a-C2a	E4a-A2a
G1b-G1b	G2b-E1b	G3b-C1b	G4b-A1b
G1a-G1a	G2a-E1a	G3a-C1a	G4a-A1a

ORTHO PIN MAPPING			
OPTION 270 (NEAR SIDE - FAR SIDE)			
A1b-A1a	A2b-C1a	A3b-E1a	A4b-G1a
A1a-A1b	A2a-C1b	A3a-E1b	A4a-G1b
C1b-A2a	C2b-C2a	C3b-E2a	C4b-G2a
C1a-A2b	C2a-C2b	C3a-E2b	C4a-G2b
E1b-A3a	E2b-C3a	E3b-E3a	E4b-G3a
E1a-A3b	E2a-C3b	E3a-E3b	E4a-G3b
G1b-A4a	G2b-C4a	G3b-E4a	G4b-G4a
G1a-A4b	G2a-C4b	G3a-E4b	G4a-G4b

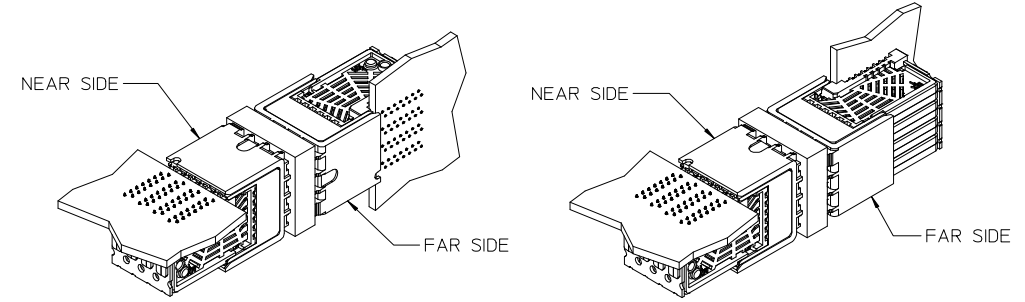

OPTION 90

OPTION 270

NOTES:



SIGNAL PAIRS (SHARED VIAS)

○ NEAR SIDE GROUNDS

○ FAR SIDE GROUNDS

SEE SHEET 1 EC NO: UCP2013-1898 TDRWINPOFF 2012/11/12 CHKD:WOLFE 2012/11/12 APPR:SMILLER 2012/12/21	QUALITY SYMBOLS ▽=0 ▽=0 ▽=0	GENERAL TOLERANCES (UNLESS SPECIFIED)		DIMENSION STYLE MM ONLY		SCALE 4:1	DESIGN UNITS METRIC	THIRD ANGLE PROJECTION			
		4 PLACES ± --- ± ---	3 PLACES ± --- ± ---	2 PLACES ± 0.13 ± ---	1 PLACE ± 0.25 ± ---	0 PLACE ± ±	DRAWN BY BPI SZCZOR 2007/01/25		DATE		
		ANGULAR ±1/2°		MATERIAL NO.		DRAWN BY JLAURX 2007/02/06		DATE		I-TRAC BACKPLANE 7 ROW UNGUIDED ASSEMBLY SALES DRAWING	
		DRAFT WHERE APPLICABLE MUST REMAIN WITHIN DIMENSIONS		SEE TABLE		APPROVED BY CBIXLER 2007/02/06		DATE		DOCUMENT NO. SD-76015-001	
				SIZE C		THIS DRAWING CONTAINS INFORMATION THAT IS PROPRIETARY TO MOLEX INCORPORATED AND SHOULD NOT BE USED WITHOUT WRITTEN PERMISSION				SHEET NO. 4 OF 4	