

MATERIAL NUMBER	OLD PART NUMBER	FINISH LENGTH
130013-0402	1R4G04A20A120	1.0'+.75"-0 [.3M+19.1-0]
130013-0404	1R4G04A20F030	3.0'+1.75"-0 [.9M+44.5-0]
130013-0405	1R4G04A20F060	6.0'+2.19"-0 [1.8+55.6-0]

VOLTAGE RATING	600 VAC/VDC
AMPERAGE RATING	10A
PROJECTION	IP67
OPERATING TEMPERATURE	-20° C TO 105° C
UL CERTIFICATIONS	UL RECOGNIZED, FILE NO. E152210
CSA CERTIFICATIONS	CSA CERTIFIED, FILE NO. LR6837

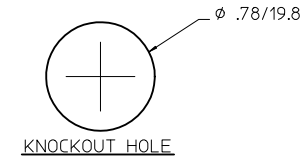
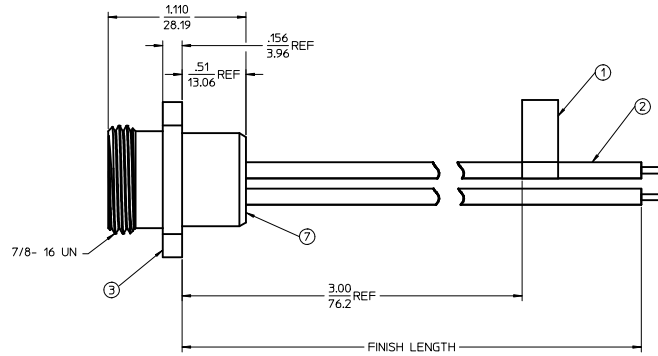
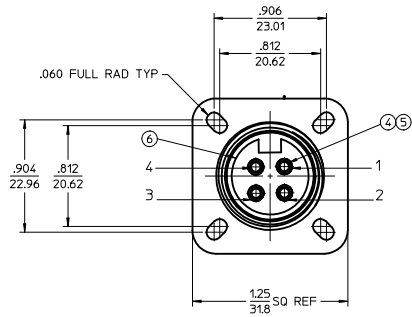
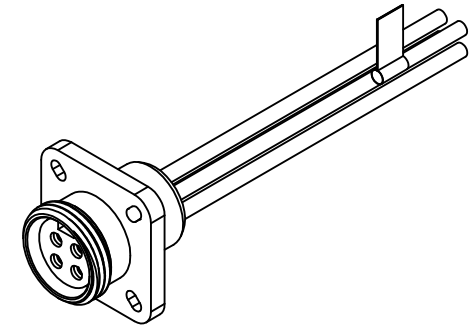

WIRING DIAGRAM

- 1 → BLACK
- 2 → WHITE
- 3 → RED
- 4 → GREEN-YELLOW

ITEM.	QTY.	COMPONENT	MATERIAL	FINISH
1	1	FLAG LABEL	PLASTIC FILM	BLACK/YELLOW
2	4	CONDUCTOR-16 AWG, 26X#30 COPPER STRANDING 600V	PVC	SEE WIRING DIAGRAM
3	1	RECEPTACLE SHELL	ALUMINUM	ANODIZED
4	4	SOCKET SLEEVE	STAINLESS STEEL	
5	4	CONTACT SOCKET	COPPER ALLOY	GOLD PLATED
6	1	4 POLE INSERT	PVC	YELLOW
7	1	POTTING	EPOXY	BLACK

UPDATE DOC EC NO: WNA2010-0423 DRAWN BY: JDRW/GRUPERT CHKD BY: WOODMAN APPR: JF MURPHY DATE: 2010/01/14 DATE: 2010/01/14	QUALITY SYMBOLS ▽=0 ▽=0	GENERAL TOLERANCES (UNLESS SPECIFIED)		DIMENSION STYLE IN/MM	SCALE 2:1	DESIGN UNITS INCH	THIRD ANGLE PROJECTION
		4 PLACES ±.--- ±.--- 3 PLACES ±. ±.005 2 PLACES ±0.13 ±.010 1 PLACE ±0.25 ±	mm INCH ±.--- ±.--- ±.005 ±.010 ± ±	DRAWN BY S. GARCIA	DATE 2009/07/01	TITLE FEMALE FLANGED RECEPTACLE MINI-CHANGE 4P 16AWG PVC	MOLEX INCORPORATED
DRAFT WHERE APPLICABLE MUST REMAIN WITHIN DIMENSIONS		APPROVED BY JF MURPHY	DATE 2010/01/14	MATERIAL NO. SEE CHART	DOCUMENT NO. SD-130013-008	SHEET NO. 1 OF 1	
THIS DRAWING CONTAINS INFORMATION THAT IS PROPRIETARY TO MOLEX INCORPORATED AND SHOULD NOT BE USED WITHOUT WRITTEN PERMISSION							