

PART NO.	ENG. NO.	
02-06-1131	1855-(P901)	
02-06-1132	1855-(P901L)	
02-06-5137	1855-(P591)	OBSOLETE
02-06-5136	1855-(P591L)	OBSOLETE
02-06-5138	1855-(P561)	
02-06-5139	1855-(P561L)	
02-06-5130	1855-(P550)	
02-06-5135	1855-(P550L)	
02-06-5147	1855-(P228)	
02-06-5148	1855-(P228L)	
02-06-1141	1855-1(P901)	
NOT TOOLED	1855-1(P901L)	
02-06-1143	1855-(P9011)	

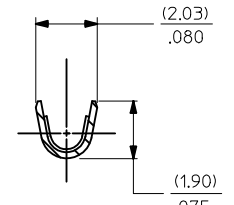
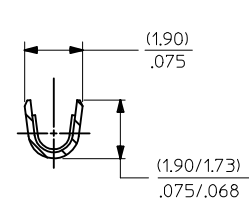
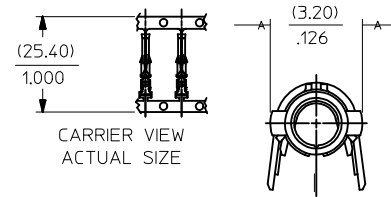

LEGEND

1855-*(*****)*

- BLANK=WITH LOCKING TABS
- 1=WITHOUT LOCKING TABS
- P=PREPLATE
- BLANK=POSTPLATE
- FORM
- BLANK=CHAIN
- 1=CHAIN WITH INTERLEAF PAPER ON REEL.
- L=LOOSE
- FINISH CODE

NOTES:

1. MATERIAL: BRASS
2. FINISHES:
 - 901 HOT TIN DIP (.00051)/.000020 MIN.
 - * 228 SELECT GOLD PLATE (.00075)/.000030 MIN. IN CONTACT AREA, SELECT TIN (.00250)/.000100 MIN. IN CRIMP AREA OVER (.00125)/.000050 MIN. NICKEL OVERALL, WITH .000010/(0.00025) MAX. SELECT GOLD FLASH IN AREA INDICATED.
 - 561 SELECT GOLD PLATE (.00076)/.000030 MIN. IN CONTACT AREA, (.00127)/.000050 MIN. NICKEL OVERALL.
 - 591 SELECT GOLD PLATE (.00127)/.000050 MIN. IN CONTACT AREA, OVER (.00127)/.000050 MIN. NICKEL OVERALL WITH (.00025)/.000010 MAX. GOLD FLASH OVERALL.
 - 550 SELECT GOLD PLATE (.00038)/.000015 MIN. IN CONTACT AREA, OVER (.00076)/.000030 MIN. NICKEL OVERALL WITH (.00025)/.000010 MAX. GOLD FLASH OVERALL.
- * THE PRIMARY SHIPPING CARTON WILL BE LABELED, *COMPLIANT TO RoHS DIRECTIVE 2002/95/EC AND ELV ANNEX II OF DIRECTIVE 2000/53/EC THIS LABEL MAY CONTAIN PRODUCT WITH TIN-LEAD.
3. PRODUCT SPECIFICATION: PS-02-0-6
4. PACKAGE INFORMATION: NOT AVAILABLE
5. TERMINAL FOR USE WITH (1.57)/.062 DIA. SERIES HOUSINGS AND WILL ACCEPT 24 THRU 30 AWG WIRE WITH (1.02/2.29)/.040/.090 INSULATION DIAMETER.

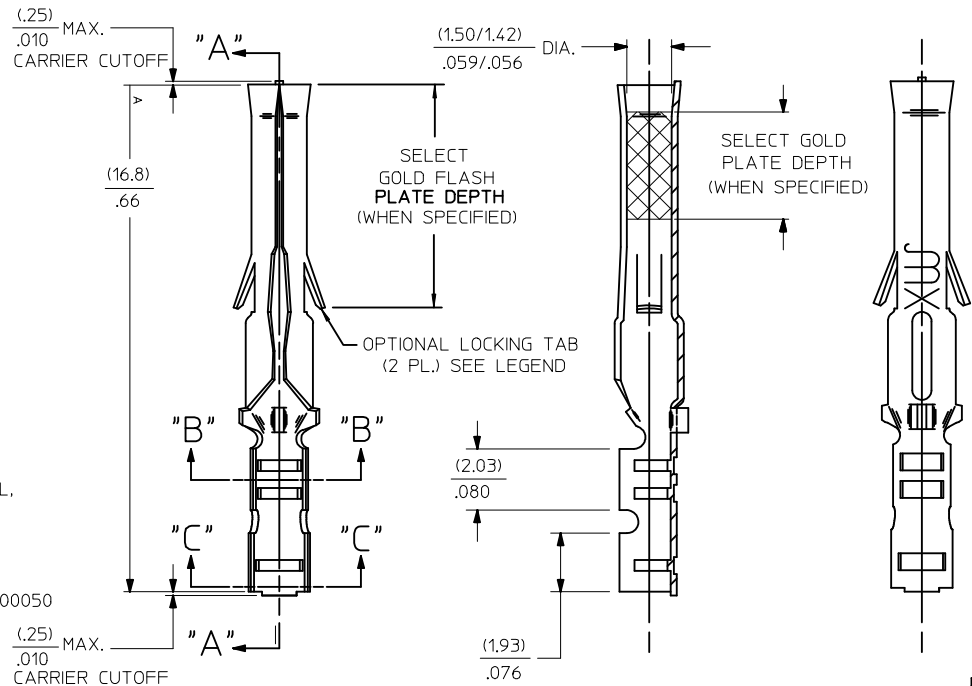

AP	REVISE Sn/Pb PLATE REDRAWN TO ME10 UCP2004-2097 5/07/04 RHOLTS
AN	OBSOLETE P/N UCR2002-0270 COMERC 01/9/28
AM1	OBSOLETE -P5751 & -P5751L ECR U6 0356 C/C 9/15/95 RW
AM	REV. AND REDRAWN PER ECR 10372 GEP 6-17-87 RW

REV. MATL. SPEC/USTAT TO ME10 EC NO: UCP2004-2097 DRAWN:RHOLTS 2004/05/14 CHKD: 2004/05/14 APPR:FSMITH 2004/05/18	QUALITY SYMBOLS	GENERAL TOLERANCES (UNLESS SPECIFIED)	SCALE 8:1	DESIGN UNITS INCH	THIRD ANGLE PROJECTION	REVISE ON CAD ONLY
	DESCRIPTION	mm INCH	DIMENSION STYLE IN/MM	DRAWN BY GEP	DATE 1987/09/17	TITLE CRIMP TERMINAL, FEMALE (1.57)/.062 DIA., BRASS FOR 24 THRU 30 GA. WIRE
	AP	ANGULAR ±1/2°	DRAFT WHERE APPLICABLE	APPROVED BY RAS	DATE 1987/09/17	MATERIAL NO. SEE CHART
		MUST REMAIN WITHIN DIMENSIONS	THIS DRAWING CONTAINS INFORMATION THAT IS PROPRIETARY TO MOLEX INCORPORATED AND SHOULD NOT BE USED WITHOUT WRITTEN PERMISSION			