

注記NOTES

1. 使用材料 MATERIAL
 - ハウジング : ポリアミド (PA)、ナチュラル(白色)、ガラス充填、UL94V-0
 - HOUSING : POLYAMIDE ,NATURAL(WHITE) ,GLASS FILLED ,UL94V-0
 - アクチュエータ : ポリフェニレンサルファイド(PPS)、ナチュラル(茶色)、ガラス充填、UL94V-0
 - ACTUATOR : POLYPHENYLENE SULFIDE,NATURAL(BROWN),GLASS FILLED UL94V-0
 - ターミナル : リン青銅(t=0.2)
 - TERMINAL : PHOSPHOR BRONZE(t=0.2)
 - 金具 : リン青銅(t=0.2)
 - FITTING NAIL : PHOSPHOR BRONZE(t=0.2)
2. メッキ仕様 PLATING
 - ターミナル TERMINAL
 - 錫銀ビスマスメッキ(1.0μm以上)
 - 下地メッキ: ニッケルメッキ(1.0μm以上)
 - TIN SILVER BISMUTH PLATING (1.0 MICROMETER MINIMUM)
 - UNDER PLATING : NICKEL PLATING (1.0 MICROMETER MINIMUM)
 - 金具 NAIL
 - 錫系メッキ(1.0μm以上)
 - 下地メッキ: ニッケルメッキ(1.0μm以上)
 - TIN BASED PLATING (1.0 MICROMETER MINIMUM)
 - UNDER PLATING : NICKEL PLATING (1.0 MICROMETER MINIMUM)

3. パターンはくり止め用金具
FITTING NAIL FOR PREVENTION OF PEELING OF P.C.B PATTERN.
4. ソルダータール半田付け面のズレ量、及び金具はんだ付け面のズレ量は、基準面 Y に対し上方向0.05MAX、下方向0.2MAX、とする。
MISALIGNMENT OF SOLDER TAILS AND FITTING NAILS FROM Y UPPER DIRECTION : 0.05 MAX. LOWER DIRECTION : 0.2 MAX. 偶数極に適用。
5. APPLY FOR EVEN CIRCUIT.
6. R0.3は、FPCの導体部にかからないこと。
R0.3 MUST NOT BE OVERLAPPED TO PATTERN OF FPC.
7. 18極以上は2か所、8~16極はハウジングセンターに1か所とする。
18 CKTS AND MOER THAN 18 CKTS PLACED 2 POINTS. 8~16 CKTS PLACED 1 POINT ON HOUSING CENTER.
8. ソルダータールの平坦度は、0.10 MAXIMUMとする。
SOLDER TAIL COPLANARITY IS 0.10 MAXIMUM.
9. ELV及びRoHS適合品
ELV AND ROHS COMPLIANT.

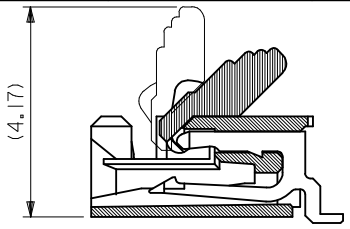

アクチュエータを開口した状態
WHEN ACTUATOR IS OPEN

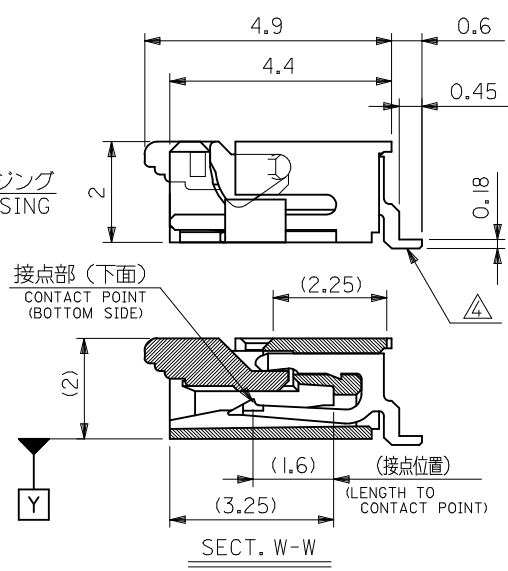
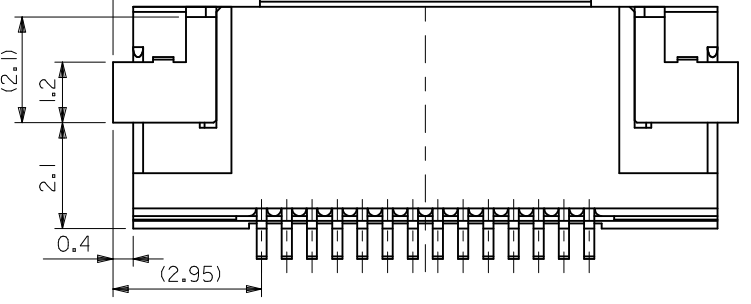
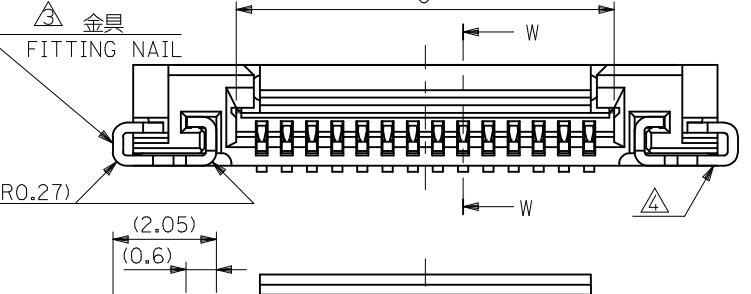
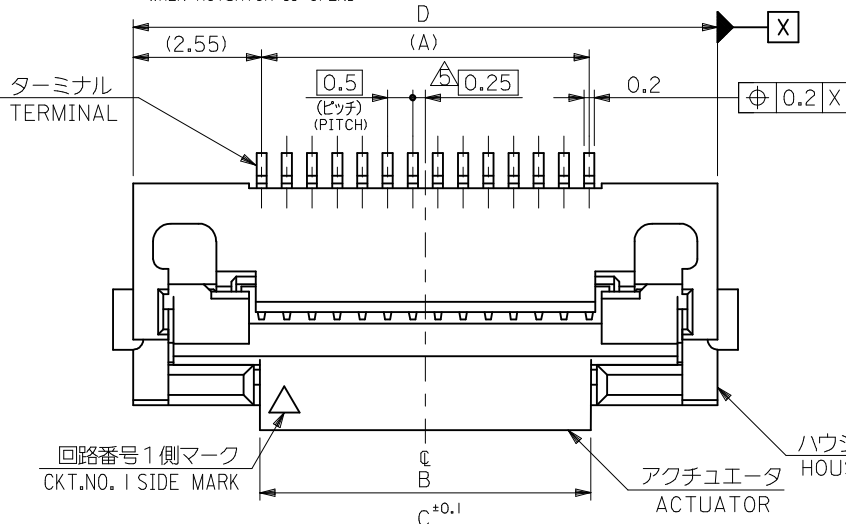

19.6	15.5	14.57	14.5	52892-3033	30
18.6	14.5	13.57	13.5	-2833	28
17.6	13.5	12.57	12.5	-2633	26
16.6	12.5	11.57	11.5	-2433	24
15.6	11.5	10.57	10.5	-2233	22
14.6	10.5	9.57	9.5	-2033	20
14.1	10.0	9.07	9.0	-1933	19
13.6	9.5	8.57	8.5	-1833	18
13.1	9.0	8.07	8.0	-1733	17
12.6	8.5	7.57	7.5	-1633	16
12.1	8.0	7.07	7.0	-1533	15
11.6	7.5	6.57	6.5	-1433	14
11.1	7.0	6.07	6.0	-1333	13
10.6	6.5	5.57	5.5	-1233	12
10.1	6.0	5.07	5.0	-1133	11
9.6	5.5	4.57	4.5	-1033	10
8.6	4.5	3.57	3.5	52892-0833	8
D	C	B	(A)	EMBOSSD TAPE ORDER No. オーダー番号	極数 CIRCUIT

CONNECTOR SERIES NO. : 52892-***22

REVISED EC NO: J2013-1212 DRWN: JASUNUMA 2013/05/01 CHKD: TAKAHASHI 2013/05/01 APPR: KMORIKAWA 2013/05/09	GENERAL TOLERANCES (UNLESS SPECIFIED)		DIMENSION STYLE MM ONLY	SCALE ---	DESIGN UNITS METRIC	THIRD ANGLE PROJECTION
	10 UNDER	±0.2	DRAWN BY TMORISHITA	DATE 2012/09/20	TITLE 0.5MM FPC CONN ZIF R/A HOUSING ASSY (LOWER CONTACT)	
	10 OVER 30 UNDER	±0.25	CHECKED BY KTAKAHASHI	DATE 2012/09/25		
	30 OVER	±0.3	APPROVED BY KMORIKAWA	DATE 2013/04/05		
A	ANGULAR ±3 °	DRAFT WHERE APPLICABLE MUST REMAIN WITHIN DIMENSIONS	MATERIAL NO. SEE CHART	DOCUMENT NO. SD-52892-044	SHEET NO. 1 OF 3	
			SIZE A3	THIS DRAWING CONTAINS INFORMATION THAT IS PROPRIETARY TO MOLEX INCORPORATED AND SHOULD NOT BE USED WITHOUT WRITTEN PERMISSION		

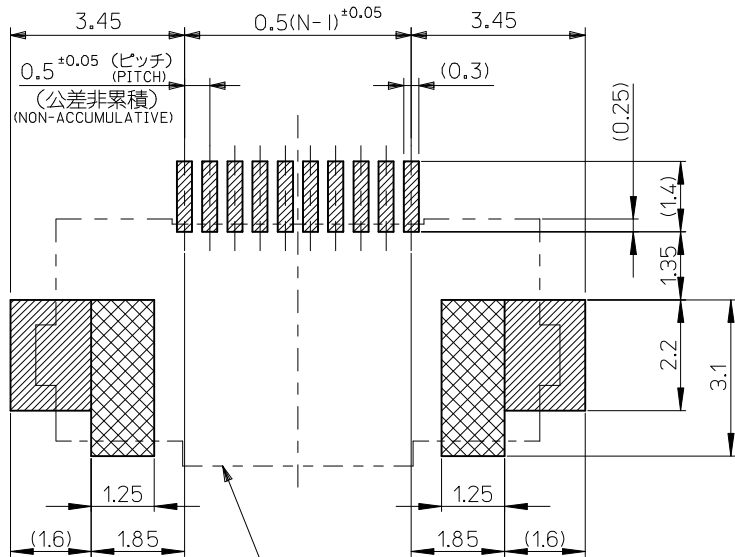

コネクタ位置
CONNECTOR POSITION

パターン禁止
NO PATTERN

推奨基板レイアウト
RECOMMENDED P.C.BOARD
PATTERN DIMENSION
(マウント面)
(MOUNTING SIDE)

参考ベスト厚 : 100 μm
参考マスク開口率 : 100%
REFERENCE SCREEN THICKNESS : 100 μm
REFERENCE SCREEN OPEN RATIO : 100%

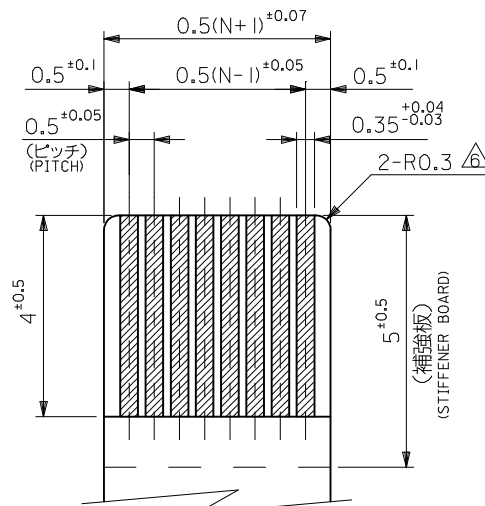

適合FPC推奨寸法
APPLICABLE FPC
RECOMMENDED DIMENSION
(仕上がり厚さ : 0.3 ± 0.03)
(THICKNESS: 0.3 ± 0.03)

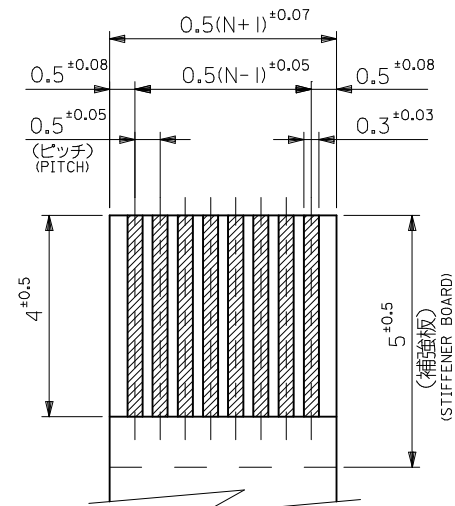

適合FFC推奨寸法
APPLICABLE FFC
RECOMMENDED DIMENSION
(仕上がり厚さ : 0.3 ± 0.03)
(THICKNESS: 0.3 ± 0.03)

FPC/FFCについて ABOUT FPC/FFC
打ち抜き方向は導体側から補強板側を推奨します。
導体部については軟烙銅35 μmまたは50 μmを推奨します。
RECOMMENDED PUNCHING DIRECTION: FROM CONDUCTOR SIDE TO STIFFENER SIDE
RECOMMENDED CONDUCTOR SPEC: SOFT COPPER FOIL
RECOMMENDED CONDUCTOR THICKNESS: 35 MICROMETER OR 50 MICROMETER

FPCについて ABOUT FPC
補強フィルム材質はポリイミドを推奨します。ベースフィルムは25 μmを推奨します。
接着剤は熱硬化接着剤を推奨します。
尚、接着剤の接点部への付着は導通不良の原因になりますので、染み出しが無い様、お願い致します。
RECOMMENDED STIFFENER MATERIAL: POLYIMIDE
RECOMMENDED BASE FILM THICKNESS: 25 MICROMETER
RECOMMENDED ADHESIVE: THERMOSETTING ADHESIVE
NOTE: PLEASE PUT APPROPRIATE AMOUNT OF ADHESIVE ON ADHEREND BECAUSE THERE IS A POSSIBILITY THAT THE EXTRA ADHESIVE CAUSES THE DEFECT IN ELECTRICAL CONTINUITY.

REVISED EC NO: J2013-1212 DRWN: JASUNUMA 2013/05/01 CHKD: KTAKAHASHI 2013/05/01 APPR: KMORIKAWA 2013/05/09	DESCRIPTION	GENERAL TOLERANCES (UNLESS SPECIFIED)		DIMENSION STYLE MM ONLY		SCALE ---	DESIGN UNITS METRIC	THIRD ANGLE PROJECTION	
		10 UNDER	± 0.2	DRAWN BY TMORISHITA	DATE 2012/09/20	TITLE 0.5MM FPC CONN ZIF R/A HOUSING ASSY (LOWER CONTACT)			
		10 OVER 30 UNDER	± 0.25	CHECKED BY KTAKAHASHI	DATE 2012/09/25	molex			
		30 OVER	± 0.3	APPROVED BY KMORIKAWA	DATE 2013/04/05				
ANGULAR	± 3 °	DRAFT WHERE APPLICABLE MUST REMAIN WITHIN DIMENSIONS		MATERIAL NO. SEE SHEET 1	DOCUMENT NO. SD-52892-044	SHEET NO. 2 OF 3			
REV A		SIZE A3 THIS DRAWING CONTAINS INFORMATION THAT IS PROPRIETARY TO MOLEX INCORPORATED AND SHOULD NOT BE USED WITHOUT WRITTEN PERMISSION							

HSGの金型によって基板面に溝が有る製品と無い製品が存在します。
 PRESENCE OR ABSENCE OF THE GROOVE TO HOUSING IS PRESENT.

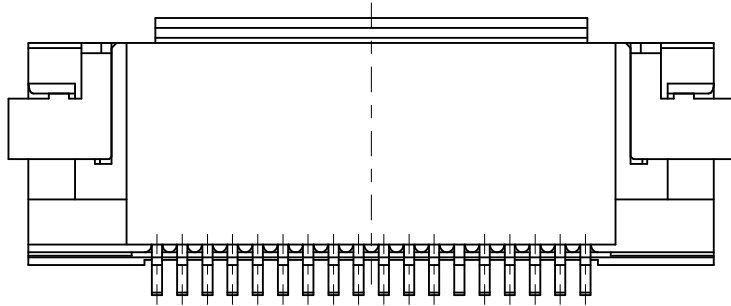
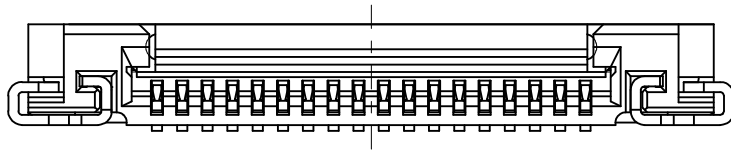

ハウジング溝無し
 NO GROOVE HOUSING

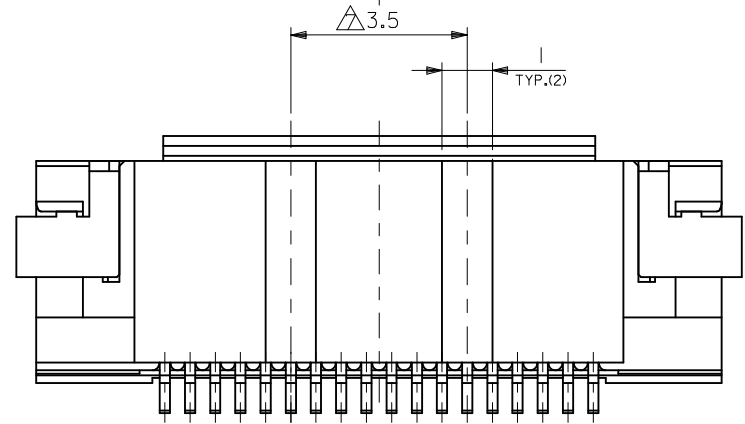
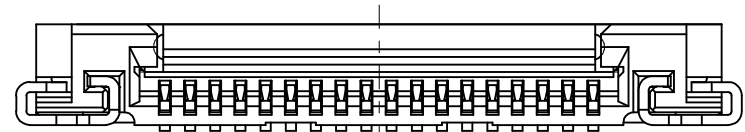

ハウジング溝付き
 GROOVED HOUSING

REVISED EC NO: J2013-1212 DRWN: JASANUMA 2013/05/01 CHKD: KTAKAHASHI 2013/05/01 APPR: KMORIKAWA 2013/05/09	GENERAL TOLERANCES (UNLESS SPECIFIED)		DIMENSION STYLE MM ONLY	SCALE ---	DESIGN UNITS METRIC	THIRD ANGLE PROJECTION
	10 UNDER	±0.2	DRAWN BY TMORISHITA	DATE 2012/09/20	TITLE 0.5MM FPC CONN ZIF R/A HOUSING ASSY (LOWER CONTACT)	
	10 OVER 30 UNDER	±0.25	CHECKED BY KTAKAHASHI	DATE 2012/09/25	molex DOCUMENT NO. SD-52892-044 SHEET NO. 3 OF 3	
	30 OVER	±0.3	APPROVED BY KMORIKAWA	DATE 2013/04/05		
	ANGULAR ±3 °		MATERIAL NO. SEE SHEET 1			
DRAFT WHERE APPLICABLE MUST REMAIN WITHIN DIMENSIONS		SIZE A3	THIS DRAWING CONTAINS INFORMATION THAT IS PROPRIETARY TO MOLEX INCORPORATED AND SHOULD NOT BE USED WITHOUT WRITTEN PERMISSION			

注記 NOTES

- 製品詳細寸法については図面 SD-52892-044 を参照下さい。
RE DETAILED DIMENSION, SEE SD-52892-044
- 梱包数量：1000個/リール
NUMBER OF CONNECTORS : 1000PCS/REEL
- リードテープ長さ LEAD TAPE LENGTH

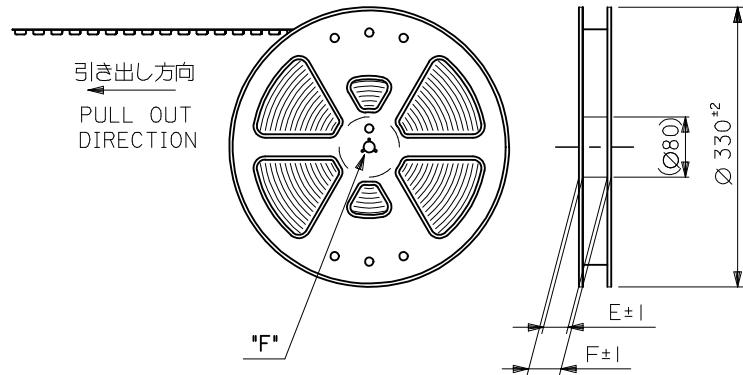

引き出し方向
PULL OUT
DIRECTION

"F"

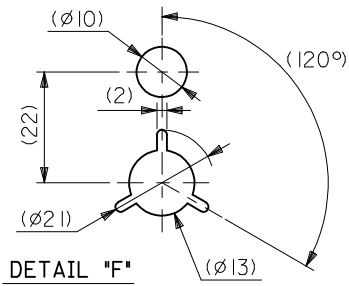

DETAIL "F"

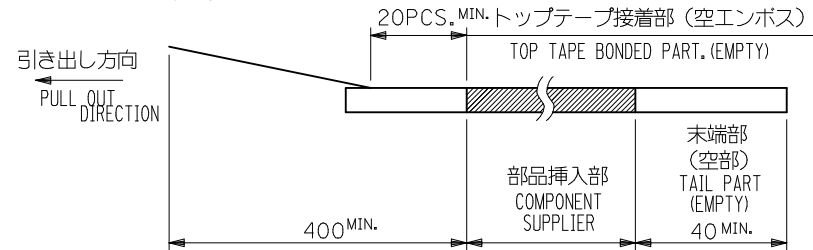

- カバーテープの剥離強度については、IEC60286-3に準拠
COVER TAPE PEELFORCE IS DEFINED BY IEC60286-3.
- 材料 (MATERIAL)
キャリアテープ (CARRIER TAPE) : ポリプロピレン (POLYPROPYLENE)
トップテープ (TOPTAPE) : PET, PE, PEF
リール (REEL) : ポリスチレン (PS) <リサイクル材を含む>
POLYSTYRENE (PS) <RECYCLE MATERIAL CONTAINED>
- ELV 及び RoHS 適合品
ELV AND ROHS COMPLIANT

RELEASED EC NO: J2013-1015 DRWN: TMORISHITA 2012/09/20 CHKD: KTAKAHASHI 2012/09/25 APPR: KMORIKAWA 2013/04/05	GENERAL TOLERANCES (UNLESS SPECIFIED)		DIMENSION STYLE MM ONLY		SCALE ---	DESIGN UNITS METRIC	THIRD ANGLE PROJECTION	
	10 UNDER	± ---	DRAWN BY TMORISHITA	DATE 2012/09/20	TITLE EMBOSS TAPE PACKAGED FOR 0.5MM FPC CONN ZIF R/A HOUSING ASSY			
	10 OVER 30 UNDER	± ---	CHECKED BY KTAKAHASHI	DATE 2012/09/25				
	30 OVER	± ---	APPROVED BY KMORIKAWA	DATE 2013/04/05	MATERIAL NO. SEE CHART		DOCUMENT NO. SD-52892-045	
ANGULAR ± --- °		DRAFT WHERE APPLICABLE MUST REMAIN WITHIN DIMENSIONS		THIS DRAWING CONTAINS INFORMATION THAT IS PROPRIETARY TO MOLEX INCORPORATED AND SHOULD NOT BE USED WITHOUT WRITTEN PERMISSION				

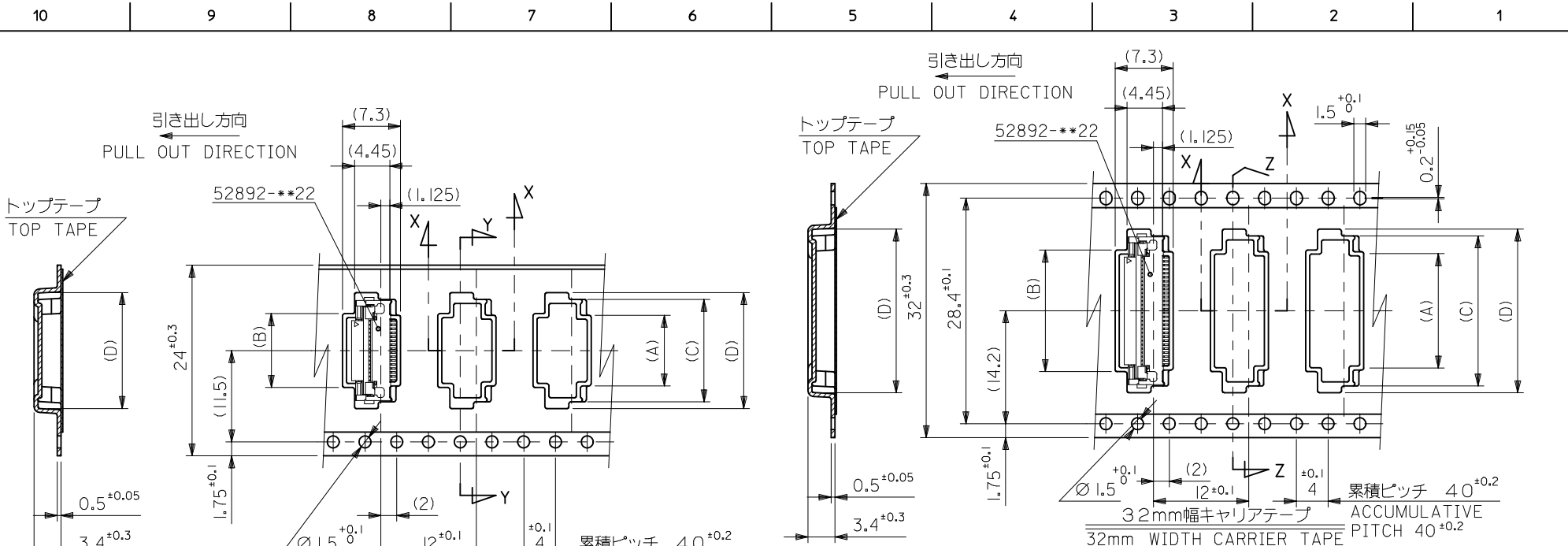

SECT : Y-Y

24mm幅キャリアテープ
24mm WIDTH CARRIER TAPE

SECT : X-X

SECT : Z-Z

Carrier Tape Width (mm)	Carrier Tape Width (mm)	Carrier Tape Width (mm)	(D)	(C)	(B)	(A)	52892-3033	30
32	37.4	33.4	21.6	19.9	16.1	15.9	-2833	28
			20.6	18.9	15.1	14.9	-2633	26
			19.6	17.9	14.1	13.9	-2433	24
			18.6	16.9	13.1	12.9	-2233	22
			17.6	15.9	12.1	11.9	-2033	20
24	29.4	25.4	16.6	14.9	11.1	10.9	-1933	19
			16.1	14.4	10.6	10.4	-1833	18
			15.6	13.9	10.1	9.9	-1733	17
			14.6	12.9	9.1	8.9	-1633	16
			14.1	12.4	8.6	8.4	-1533	15
			13.6	11.9	8.1	7.9	-1433	14
			13.1	11.4	7.6	7.4	-1333	13
			12.6	10.9	7.1	6.9	-1233	12
			12.1	10.4	6.6	6.4	-1133	11
			11.6	9.9	6.1	5.9	-1033	10
10.6	8.9	5.1	4.9	-833	8			
キャリアテープ幅 CARRIER TAPE WIDTH							52892-0833	8
							EMBOSSED PACKAGE	極致
							ORDER No. オダー番号	CIRCUIT

CONNECTOR SERIES NO. : 52892-***22

RELEASED EC NO: J2013-1015 DRWN: TMORISHITA 2012/09/20 CHKD: KTAKAHASHI 2012/09/25 APPR: KMORIKAWA 2013/04/05	GENERAL TOLERANCES (UNLESS SPECIFIED)		DIMENSION STYLE MM ONLY		SCALE ---	DESIGN UNITS METRIC	THIRD ANGLE PROJECTION	
	10 UNDER	± ---	DRAWN BY TMORISHITA	DATE 2012/09/20	TITLE EMBOSS TAPE PACKAGED FOR 0.5MM FPC CONN ZIF R/A (LOWER CONTACT)			
	10 OVER 30 UNDER	± ---	CHECKED BY KTAKAHASHI	DATE 2012/09/20				
	30 OVER	± ---	APPROVED BY KMORIKAWA	DATE 2013/04/05				
	ANGULAR	± --- °	MATERIAL NO.		DOCUMENT NO.	SHEET NO.		
DRAFT WHERE APPLICABLE MUST REMAIN WITHIN DIMENSIONS		SEE CHART		SD-52892-045		2 OF 2		
		THIS DRAWING CONTAINS INFORMATION THAT IS PROPRIETARY TO MOLEX INCORPORATED AND SHOULD NOT BE USED WITHOUT WRITTEN PERMISSION						