

REVISED EC NO.: J2012-0856 DRWN:KMIYAHARA 2012/01/05 CHKD:KMIYAHARA 2012/01/05 APPR:KMORIKAWA 2012/02/07	DESCRIPTION	GENERAL TOLERANCES (UNLESS SPECIFIED)		DIMENSION STYLE MM ONLY		SCALE ---	52610-**15	MODEL NO.	
		10 UNDER	±0.2	DRAWN BY M. NABEI	DATE '05/07/21	TITLE	DESIGN UNITS METRIC	THIRD ANGLE PROJECTION	
		10 OVER 30 UNDER	±0.25	CHECKED BY K. TOYODA	DATE '05/07/21	1.0 FPC CONN ZIF FOR SMT ST -LEAD FREE-	MOLEX INCORPORATED	DOCUMENT NO. SD-52610-036	SHEET NO. 1 OF 2
		30 OVER	±0.3	APPROVED BY N. UKITA	DATE '05/07/21				
REV		ANGULAR ±3 °	DRAFT WHERE APPLICABLE MUST REMAIN WITHIN DIMENSIONS		SEE TABLE		THIS DRAWING CONTAINS INFORMATION THAT IS PROPRIETARY TO MOLEX INCORPORATED AND SHOULD NOT BE USED WITHOUT WRITTEN PERMISSION		

注記 (NOTES) :

1. 材料 (MATERIAL)

ハウジング (HOUSING) : 46NYLON , UL94V-0
 アクチュエータ (ACTUATOR) : PPS , UL94V-0
 ターミナル (TERMINAL) : リン青銅 (t O. 32)

△ 偶数極に適用。
 APPLY FOR EVEN CIRCUIT.

5. 本製品は 52610 シリーズの接点金メッキ品である。
 THIS PRODUCT IS Au-CONTACT OF 52610 SERIES.

PHOS-BRO
 接点部 : 金メッキ 0.1μm 以上
 テール部 : 錫メッキ 1μm 以上
 下地 : ニッケルメッキ 1μm 以上
 CONTACT : GOLD 0.1 MICROMETER MINIMUM
 TAIL : MATTE TIN 1 MICROMETER MINIMUM
 NICKEL : UNDER 1 MICROMETER MINIMUM

2. エンボステープ梱包時は、アクチュエータがロックした状態とする。
 IN THE PACKAGE , ACTUATOR OF PART NO. 52610-**59 SHOULD BE LOCKED.
- △ ソルダータール半田付け面のズレ量は、基準面 [F] に対し上方向 0.05 MAX.、
 下方向 0.15 MAX. とする。
 MISALIGNMENT OF SOLDER TAILS FROM [F] UPPER DIRECTION : 0.05 MAX. ,
 LOWER DIRECTION : 0.15 MAX.

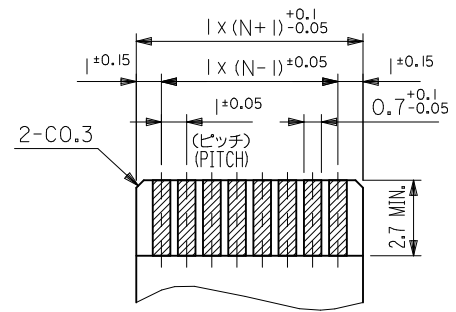

適合 FPC 推奨寸法
 APPLICABLE FPC RECOMMENDED DIM.
 仕上がり厚さ (THICKNESS) : 0.3 ± 0.05

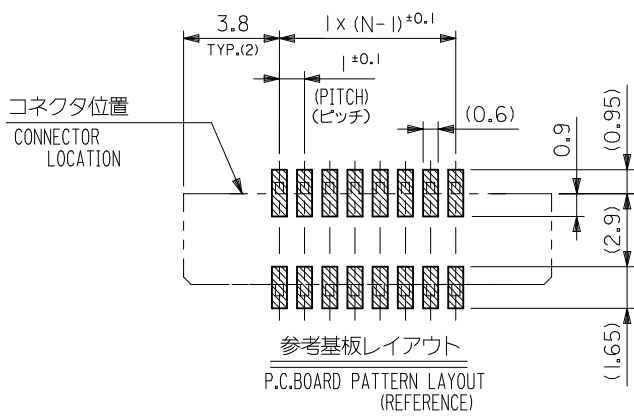

36.6	34.85	31.2	29	52610-3072	52610-3015	30
32.6	30.85	27.2	25	52610-2672	52610-2615	26
31.6	29.85	26.2	24	52610-2572	52610-2515	25
30.6	28.85	25.2	23	52610-2472	52610-2415	24
28.6	26.85	23.2	21	52610-2272	52610-2215	22
26.6	24.85	21.2	19	52610-2072	52610-2015	20
25.6	23.85	20.2	18	52610-1972	52610-1915	19
24.6	22.85	19.2	17	52610-1872	52610-1815	18
23.6	21.85	18.2	16	52610-1772	52610-1715	17
22.6	20.85	17.2	15	52610-1672	52610-1615	16
21.6	19.85	16.2	14	52610-1572	52610-1515	15
20.6	18.85	15.2	13	52610-1472	52610-1415	14
19.6	17.85	14.2	12	52610-1372	52610-1315	13
18.6	16.85	13.2	11	52610-1272	52610-1215	12
17.6	15.85	12.2	10	52610-1172	52610-1115	11
16.6	14.85	11.2	9	52610-1072	52610-1015	10
15.6	13.85	10.2	8	52610-0972	52610-0915	9
14.6	12.85	9.2	7	52610-0872	52610-0815	8
12.6	10.85	7.2	5	52610-0672	52610-0615	6
11.6	9.85	6.2	4	52610-0572	52610-0515	5

52610-**15	D	(C)	B	(A)	EMBOSSSED TAPE	MATERIAL. NO.	極数 CKT.
MODEL NO.					ORDER No. オーダー番号		

REVISED EC NO. J2012-0856 DRWN:KMIYAHARA 2012/01/05 CHKD:KMIYAHARA 2012/01/05 APPR:KMORIKAWA 2012/02/07	DESCRIPTION	GENERAL TOLERANCES (UNLESS SPECIFIED)		DIMENSION STYLE MM ONLY		SCALE	DESIGN UNITS	THIRD ANGLE PROJECTION		
		10 UNDER	± 0.2	DRAWN BY	DATE	TITLE	1.0 FPC CONN ZIF FOR SMT ST -LEAD FREE-			
		10 OVER 30 UNDER	± 0.25	CHECKED BY	DATE	MOLEX INCORPORATED				
		30 OVER	± 0.3	APPROVED BY	DATE					
ANGULAR	± 3 °	MATERIAL NO.		SEE TABLE		DOCUMENT NO.	SD-52610-036			
DRAFT WHERE APPLICABLE MUST REMAIN WITHIN DIMENSIONS		SIZE A3		THIS DRAWING CONTAINS INFORMATION THAT IS PROPRIETARY TO MOLEX INCORPORATED AND SHOULD NOT BE USED WITHOUT WRITTEN PERMISSION						

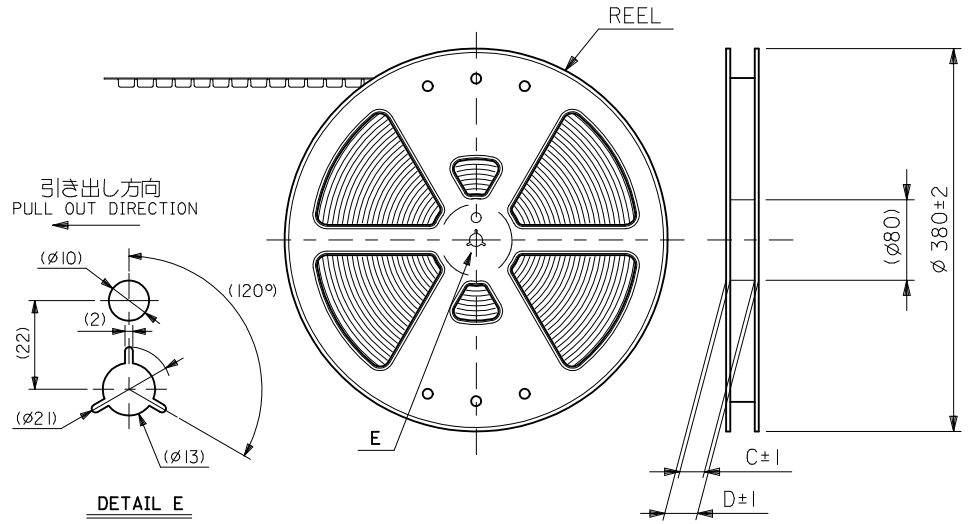

NOTES

- 梱包数量：1000個/リール
NUMBER OF CONNECTORS : 1000PCS/REEL
- リードテープ長さ LEAD TAPE LENGTH
20PCS. MIN. トップテープ接着部 (空エンボス)
TOP TAPE BONDED PART. (EMPTY)
部品挿入部 COMPONENT SUPPLIER
末端部 (空部) TAIL PART (EMPTY)
400 MIN. 40 MIN.
- 52610-***15 のアクチュエータはハウジング内に押し下げた状態とする。
詳細寸法については図面 SD-52610-036 を参照下さい。
ACTUATOR OF PART NO. 52610-***15 SHULD BE LOCKED.
RE DETAILED DIMENSIONS , SEE SD-52610-036.
- 材料 (MATERIAL)
キャリアテープ (CARRIER TAPE) : ポリプロピレン (POLYPROPYLENE)
トップテープ (TOPTAPE) : PET , PE , PEF
リール (REEL) : ポリスチレン (P S) <リサイクル材を含む>
POLYSTYRENE (PS) <RECYCLE MATERIAL CONTAINED>
- 本製品は 52610 シリーズの接点金メッキ品である。
THIS PRODUCT IS Au-CONTACT OF 52610 SERIES.
- 本製品は乾燥剤入り、ハイバリア梱包仕様である。
THIS PRODUCT IS HIGH BARRIER PACKAGE WITH DESICCANT.

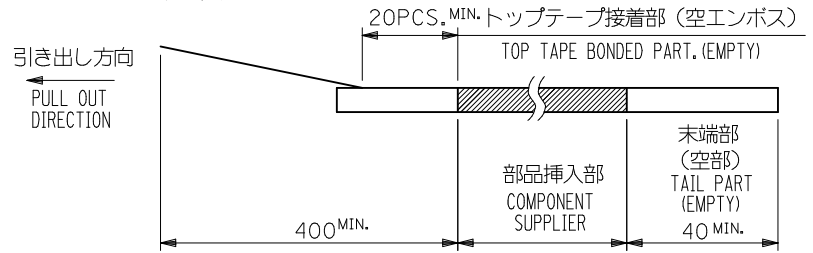

REVISED EC NO. : J2012-0856 DRAWN: KMIYAHARA 2012/01/05 CHKD: TAKAHASHI 2012/01/05 APPR: KMORIKAWA 2012/02/07	GENERAL TOLERANCES (UNLESS SPECIFIED)		DIMENSION STYLE MM ONLY		SCALE ---	52610-***72	MODEL NO.	
	10 UNDER	±0.2	DRAWN BY M. NABEI	DATE '05/07/21	TITLE 1.0 FPC CONN SMT ZIF EMBSTP PKG -LEAD FREE-	DESIGN UNITS METRIC	THIRD ANGLE PROJECTION	
	10 OVER 30 UNDER	±0.25	CHECKED BY K. TOYODA	DATE '05/07/21	APPROVED BY N. UKITA	DATE '05/07/21	MOLEX INCORPORATED	
	30 OVER	±0.3	MATERIAL NO. SEE TABLE		DOCUMENT NO. SD-52610-037	SHEET NO. 1 OF 5		
	ANGULAR ±3 °	THIS DRAWING CONTAINS INFORMATION THAT IS PROPRIETARY TO MOLEX INCORPORATED AND SHOULD NOT BE USED WITHOUT WRITTEN PERMISSION						
	DRAFT WHERE APPLICABLE MUST REMAIN WITHIN DIMENSIONS							

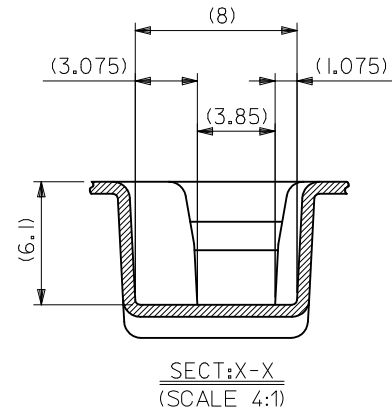
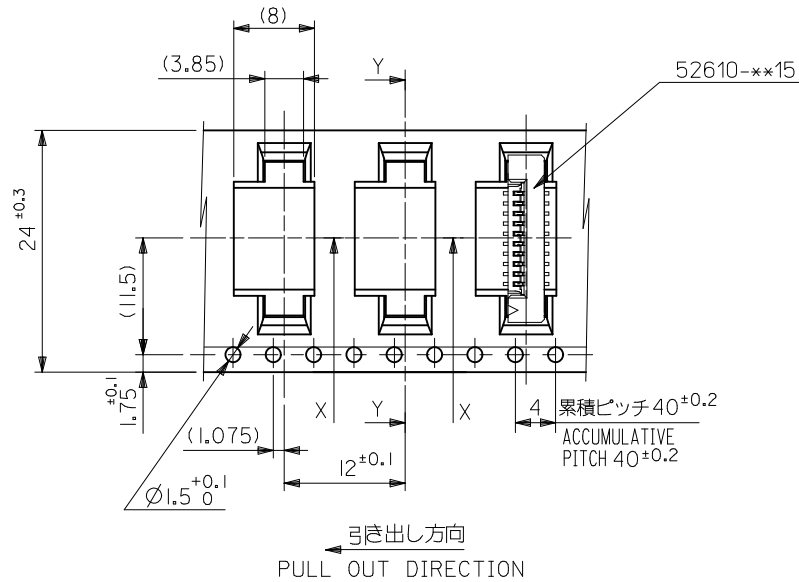
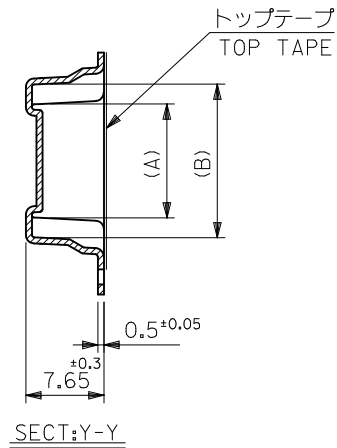

52610-**-72
MODEL NO.

24	29.4	25.4	15.25	11.32	52610-1072	10
			14.25	10.32	52610-0972	9
			13.25	9.32	52610-0872	8
			11.25	7.32	52610-0672	6
			10.25	6.32	52610-0572	5
キャリアテープ幅 CARRIER TAPE WIDTH	D	C	(B)	(A)	MATERIAL. NO.	極数 CKT.

REVISED EC NO: J2012-0856 DRWN:KMIYAHARA 2012/01/05 CHKD:KTAHASHI 2012/01/05 APP:KMORIKAWA 2012/02/07	DESCRIPTION REV	GENERAL TOLERANCES (UNLESS SPECIFIED)		DIMENSION STYLE MM ONLY		SCALE ---		DESIGN UNITS METRIC		THIRD ANGLE PROJECTION		
		10 UNDER	±0.2	DRAWN BY M. NABEI	DATE '05/07/21	TITLE 1.0 FPC CONN SMT ZIF EMBSTP PKG -LEAD FREE-						
		10 OVER 30 UNDER	±0.25	CHECKED BY K. TOYODA	DATE '05/07/21	MOLEX INCORPORATED						
		30 OVER	±0.3	APPROVED BY N. UKITA	DATE '05/07/21							
ANGULAR ±3 °		DRAFT WHERE APPLICABLE MUST REMAIN WITHIN DIMENSIONS		MATERIAL NO. SEE TABLE		DOCUMENT NO. SD-52610-037		SHEET NO. 2 OF 5				
SIZE A3		THIS DRAWING CONTAINS INFORMATION THAT IS PROPRIETARY TO MOLEX INCORPORATED AND SHOULD NOT BE USED WITHOUT WRITTEN PERMISSION										

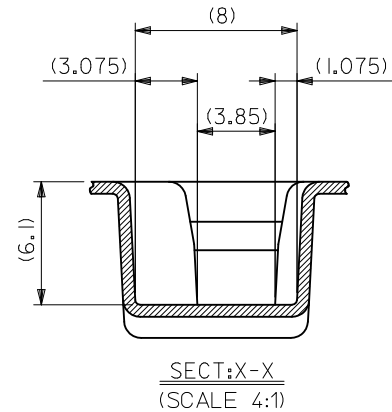
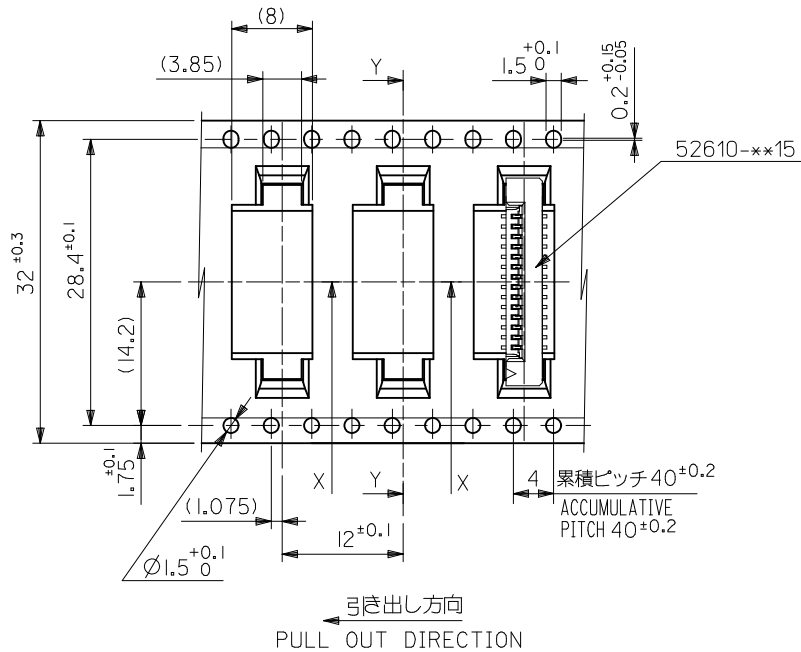
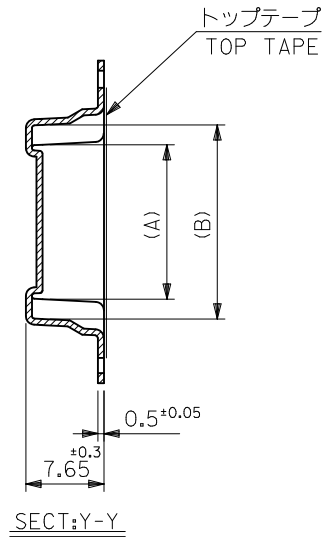

52610-**72
MODEL NO.

32	37.4	33.4	20.25	16.32	52610-1572	15	
			19.25	15.32	52610-1472	14	
			18.25	14.32	52610-1372	13	
			17.25	13.32	52610-1272	12	
			16.25	12.32	52610-1172	11	
キャリアテープ幅 CARRIER TAPE WIDTH		D	C	(B)	(A)	MATERIAL NO.	極数 CKT.

REVISED EC NO: J2012-0856 DRWN:KMIYAHARA 2012/01/05 CHK'D:KAKAHASHI 2012/01/05 APPR:KMORIKAWA 2012/02/07	GENERAL TOLERANCES (UNLESS SPECIFIED)		DIMENSION STYLE MM ONLY		SCALE ---	DESIGN UNITS METRIC	THIRD ANGLE PROJECTION
	10 UNDER	±0.2	DRAWN BY M. NABEI	DATE '05/07/21	TITLE 1.0 FPC CONN SMT ZIF EMBSTP PKG -LEAD FREE-		
	10 OVER 30 UNDER	±0.25	CHECKED BY K. TOYODA	DATE '05/07/21	MOLEX INCORPORATED		
	30 OVER	±0.3	APPROVED BY N. UKITA	DATE '05/07/21	DOCUMENT NO. SD-52610-037		
ANGULAR ±3 °		MATERIAL NO. SEE TABLE		SHEET NO. 3 OF 5			
DRAFT WHERE APPLICABLE MUST REMAIN WITHIN DIMENSIONS		THIS DRAWING CONTAINS INFORMATION THAT IS PROPRIETARY TO MOLEX INCORPORATED AND SHOULD NOT BE USED WITHOUT WRITTEN PERMISSION					

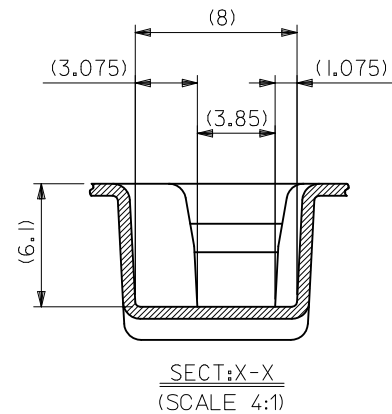
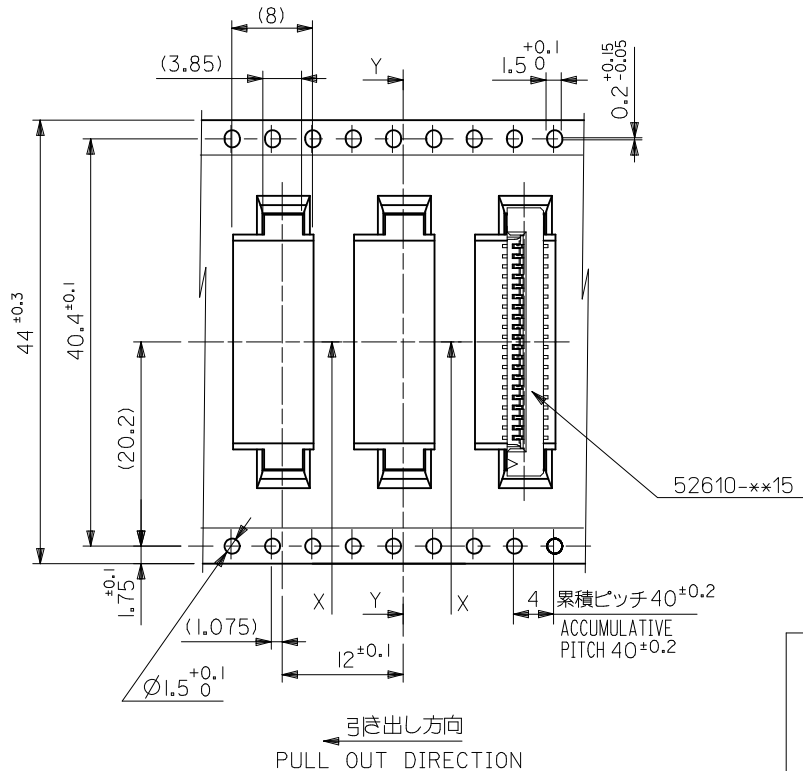
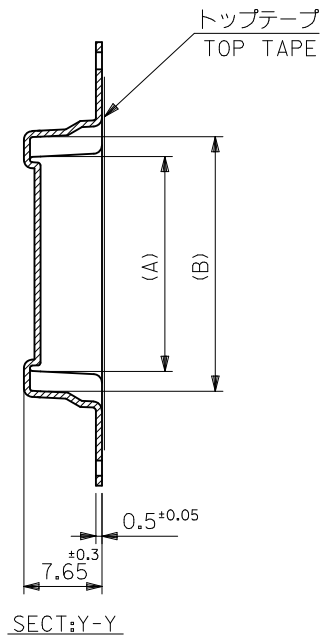

44	49.4	45.4	31.25	27.32	52610-2672	26		
			30.25	26.32	52610-2572	25		
			29.25	25.32	52610-2472	24		
			27.25	23.32	52610-2272	22		
			25.25	21.32	52610-2072	20		
			24.25	20.32	52610-1972	19		
			23.25	19.32	52610-1872	18		
			22.25	18.32	52610-1772	17		
			21.25	17.32	52610-1672	16		
52610-***72		キャリアテープ幅	D	C	(B)	(A)	MATERIAL. NO.	極数
MODEL NO.		CARRIER TAPE WIDTH						極数

REVISED EC NO: J2012-0856 DRW:KMIYAHARA 2012/01/05 CHKD: APPR:KMORIKAWA 2012/02/07	DIMENSION STYLE MM ONLY	GENERAL TOLERANCES (UNLESS SPECIFIED)		DRAWN BY	DATE	TITLE
		10 UNDER	±0.2	M. NABEI	'05/07/21	1.0 FPC CONN SMT ZIF EMBOSTP PKG -LEAD FREE- MOLEX INCORPORATED SD-52610-037
		10 OVER 30 UNDER	±0.25	K. TOYODA	'05/07/21	
		30 OVER	±0.3	N. UKITA	'05/07/21	
		ANGULAR	±3 °	MATERIAL NO.	DOCUMENT NO.	
DRAFT WHERE APPLICABLE MUST REMAIN WITHIN DIMENSIONS		SIZE	SHEET NO.			
		A3	4 OF 5			

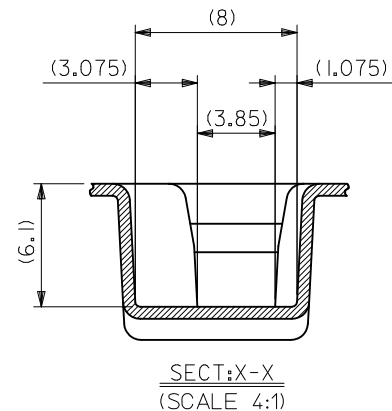
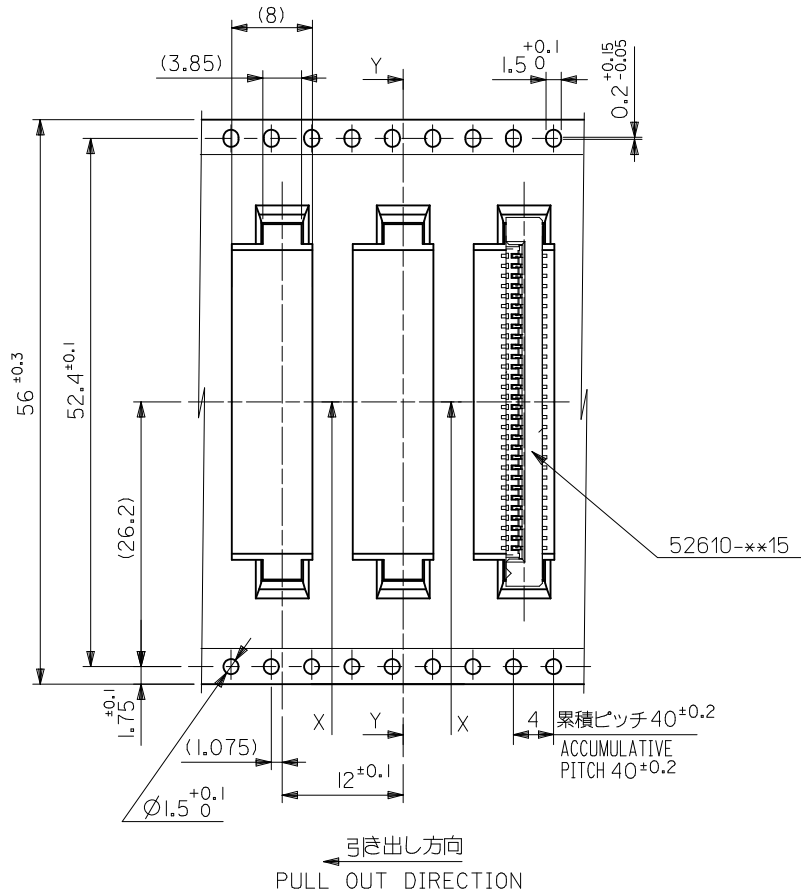
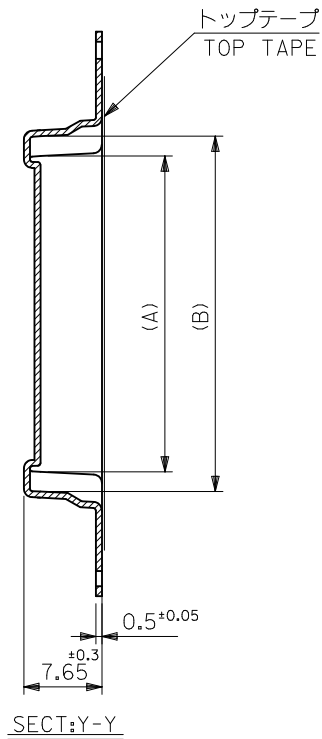

52610-**-**72	56	61.4	57.4	35.25	31.32	52610-3072	30
MODEL NO.	キャリアテープ幅 CARRIER TAPE WIDTH	D	C	(B)	(A)	MATERIAL. NO.	極数 CKT.

REVISED EC NO: J2012-0856 DRWN:KMIYAHARA 2012/01/05 CHK'D:KAKAHASHI 2012/01/05 APPR:KMORIKAWA 2012/02/07	GENERAL TOLERANCES (UNLESS SPECIFIED)		DIMENSION STYLE MM ONLY		SCALE ---	DESIGN UNITS METRIC	THIRD ANGLE PROJECTION
	10 UNDER	± 0.2	DRAWN BY M. NABEI	DATE '05/07/21	TITLE 1.0 FPC CONN SMT ZIF EMBSTP PKG -LEAD FREE-		
	10 OVER 30 UNDER	± 0.25	CHECKED BY K. TOYODA	DATE '05/07/21	MOLEX INCORPORATED		
	30 OVER	± 0.3	APPROVED BY N. UKITA	DATE '05/07/21	MATERIAL NO. SEE TABLE	DOCUMENT NO. SD-52610-037	SHEET NO. 5 OF 5
REV	DESCRIPTION	ANGULAR $\pm 3^\circ$	DRAFT WHERE APPLICABLE MUST REMAIN WITHIN DIMENSIONS		THIS DRAWING CONTAINS INFORMATION THAT IS PROPRIETARY TO MOLEX INCORPORATED AND SHOULD NOT BE USED WITHOUT WRITTEN PERMISSION		