

NOTES

- 梱包数量 : 1500個 / リール
NUMBER OF CONNECTORS : 1500 PCS/REEL.
- リードテープ長さ LEAD TAPE LENGTH.

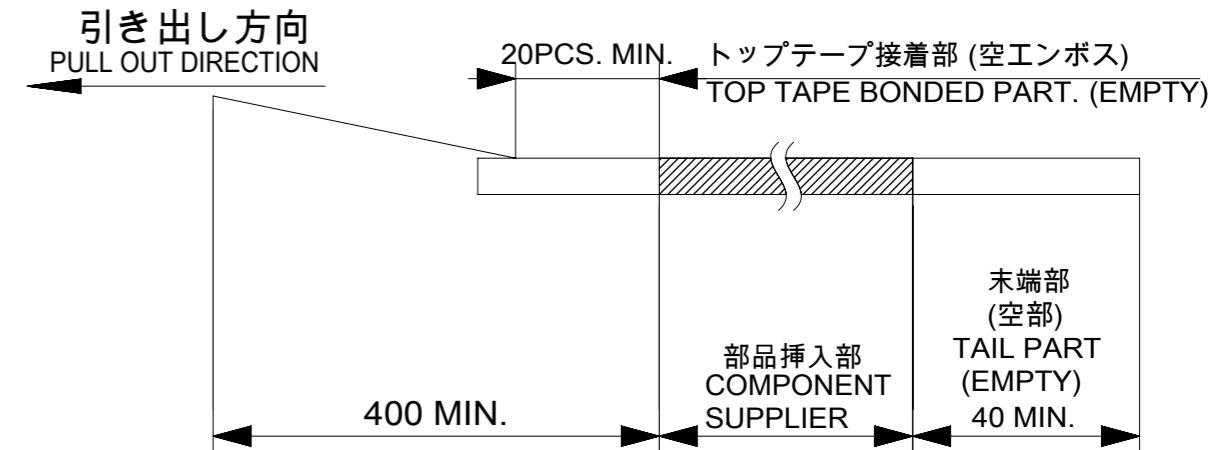

- 材料 (MATERIAL)
キャリアテープ (CARRIER TAPE) : ポリプロピレン (POLYPROPYLENE)
トップテープ (TOP TAPE) : PET, PE, PEF
リール (REEL) : ポリスチレン (POLYSTYLENE)
- 本製品は54104**96 のターミナル部分金メッキ品である。

THIS DRAWING CONTAINS INFORMATION THAT IS PROPRIETARY TO MOLEX ELECTRONIC TECHNOLOGIES, LLC AND SHOULD NOT BE USED WITHOUT WRITTEN PERMISSION										
EC NO: 103444 DRWN: NVELUSAMY CHK'D: YKOBAYASHI02 APPR: TKUSUHARA01	2016/02/16 2016/05/23 2016/05/24		GENERAL TOLERANCES (UNLESS SPECIFIED)		DIMENSION UNITS	SCALE	molex [®]			
			ANGULAR TOL ± °		MM	1:1				
			4 PLACES ±		DRWN BY	DATE	EMBOSSED TAPE PACKAGE FOR 54104**29 -LEAD FREE-			
			3 PLACES ±		NVELUSAMY	2016/02/16				
			2 PLACES ±		CHK'D BY	DATE	PRODUCT CUSTOMER DRAWING			
		1 PLACE ±		YKOBAYASHI02	2016/05/23					
		0 PLACES ±		APPR BY	DATE	SERIES MATERIAL NUMBER CUSTOMER 54104 SEE CHART GENERAL				
		DRAFT WHERE APPLICABLE MUST REMAIN WITHIN DIMENSIONS		TKUSUHARA01	2016/05/24					
A		REV		DRAWING SIZE	THIRD ANGLE PROJECTION	DOCUMENT NUMBER		DOC TYPE	DOC PART	SHEET NUMBER
				A3		541040000		PSD	000	1 OF 2

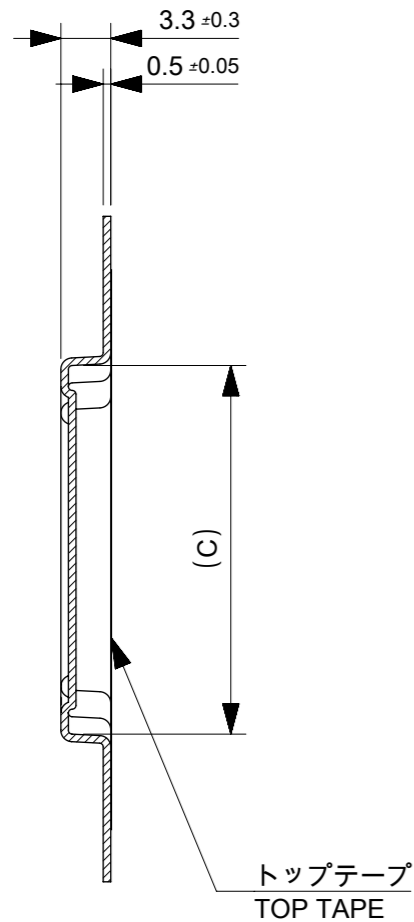

SECTION Y-Y

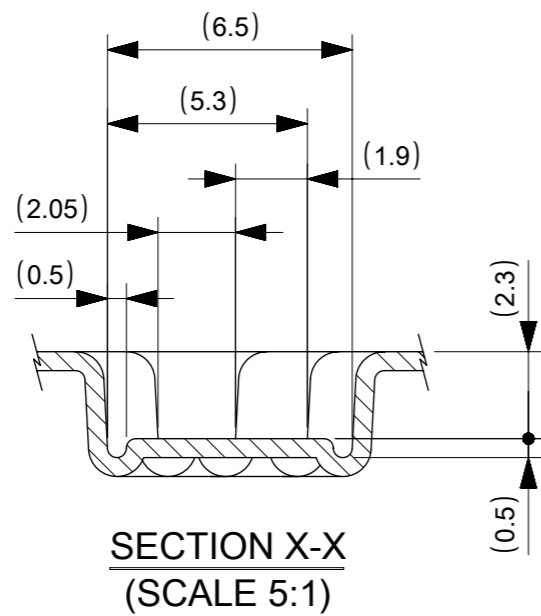
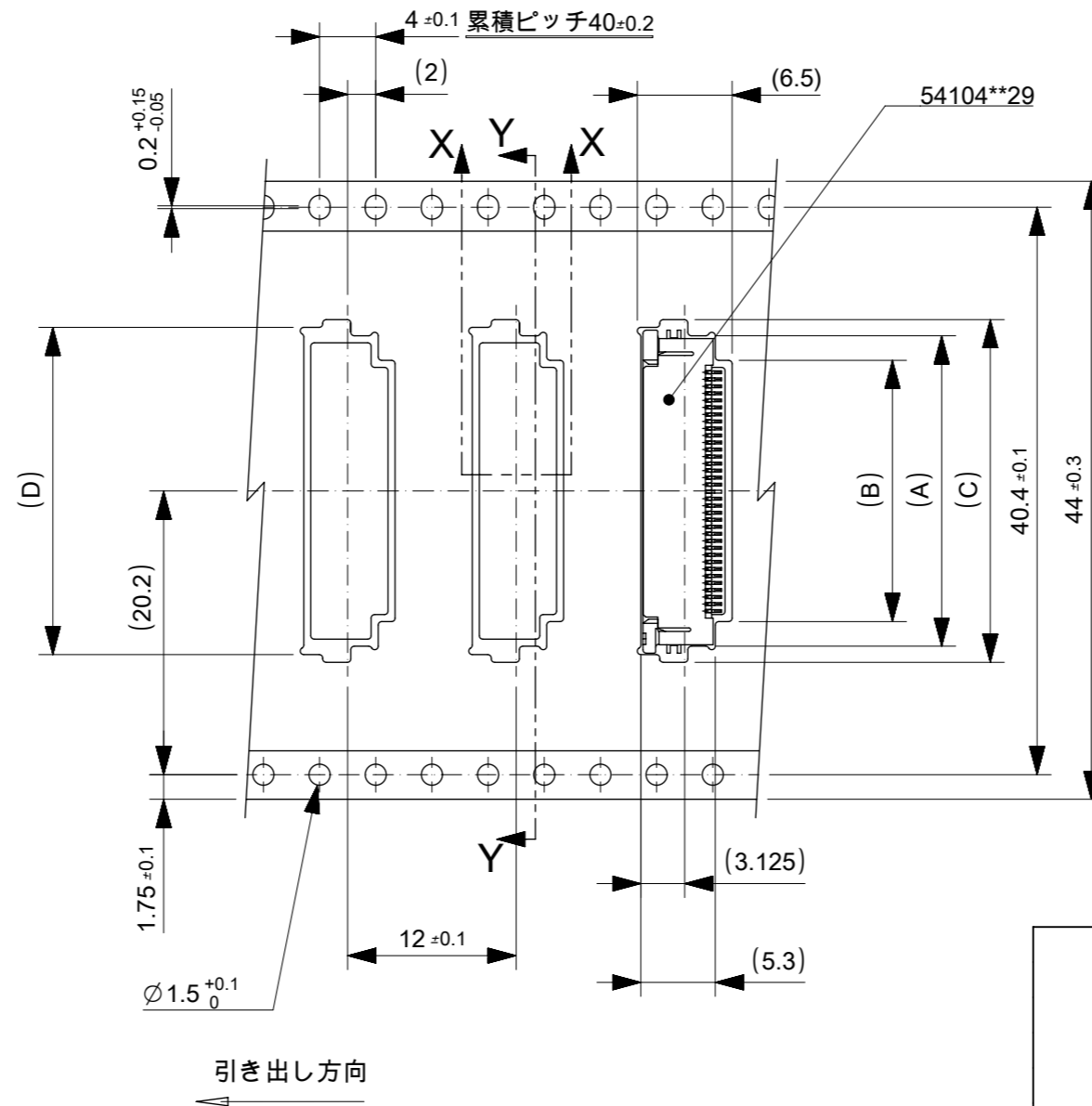

SECTION X-X
(SCALE 5:1)

44	49.4	45.4	30.8	31.9	26.1	29.6	541045031	50		
			28.8	29.9	24.1	27.6	541044631	46		
			28.3	29.4	23.6	27.1	541044531	45		
			27.8	28.9	23.1	26.6	541044431	44		
			27.3	28.4	22.6	26.1	541044331	43		
			25.8	26.9	21.1	24.6	541044031	40		
			24.8	25.9	20.1	23.6	541043831	38		
			23.8	24.9	19.1	22.6	541043631	36		
			23.3	24.4	18.6	22.1	541043531	35		
			22.8	23.9	18.1	21.6	541043431	34		
			22.3	23.4	17.6	21.1	541043331	33		
			21.8	22.9	17.1	20.6	541043231	32		
			20.8	21.9	16.1	19.6	541043031	30		
キャリアテープ幅 CARRIER TAPE WIDTH			F	E	D	C	B	A	MATERIAL NO.	CKT.

THIS DRAWING CONTAINS INFORMATION THAT IS PROPRIETARY TO MOLEX ELECTRONIC TECHNOLOGIES, LLC AND SHOULD NOT BE USED WITHOUT WRITTEN PERMISSION

EC NO: 103444 DRWN: NVELUSAMY CHK'D: YKOBAYASHI02 APPR: TKUSUHARA01	2016/02/16	GENERAL TOLERANCES (UNLESS SPECIFIED)	DIMENSION UNITS	SCALE
	2016/05/23	ANGULAR TOL ± °	MM	2:1
	2016/05/24	4 PLACES ±	DRWN BY	DATE
		3 PLACES ±	NVELUSAMY	2016/02/16
		2 PLACES ±	CHK'D BY	DATE
		1 PLACE ±	YKOBAYASHI02	2016/05/23
	0 PLACES ±	APPR BY	DATE	
		TKUSUHARA01	2016/05/24	
		DRAFT WHERE APPLICABLE MUST REMAIN WITHIN DIMENSIONS	DRAWING SIZE	THIRD ANGLE PROJECTION
			A3	

molex [®]			
EMBOSSED TAPE PACKAGE FOR 54104**29 -LEAD FREE-			
PRODUCT CUSTOMER DRAWING			
SERIES	MATERIAL NUMBER	CUSTOMER	
54104	SEE CHART	GENERAL	
DOCUMENT NUMBER		DOC TYPE	DOC PART
541040000		PSD	000
		DOC PART	SHEET NUMBER
		000	2 OF 2

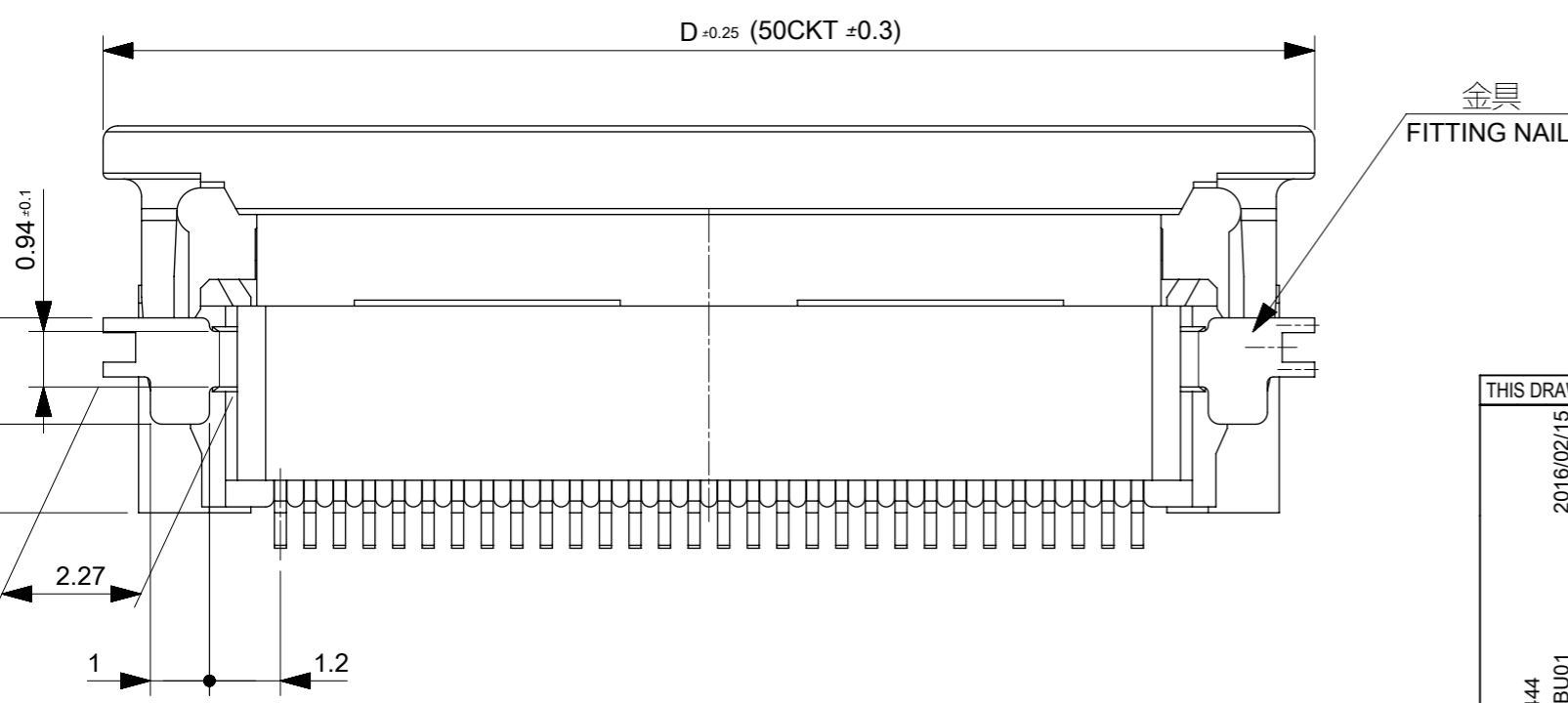
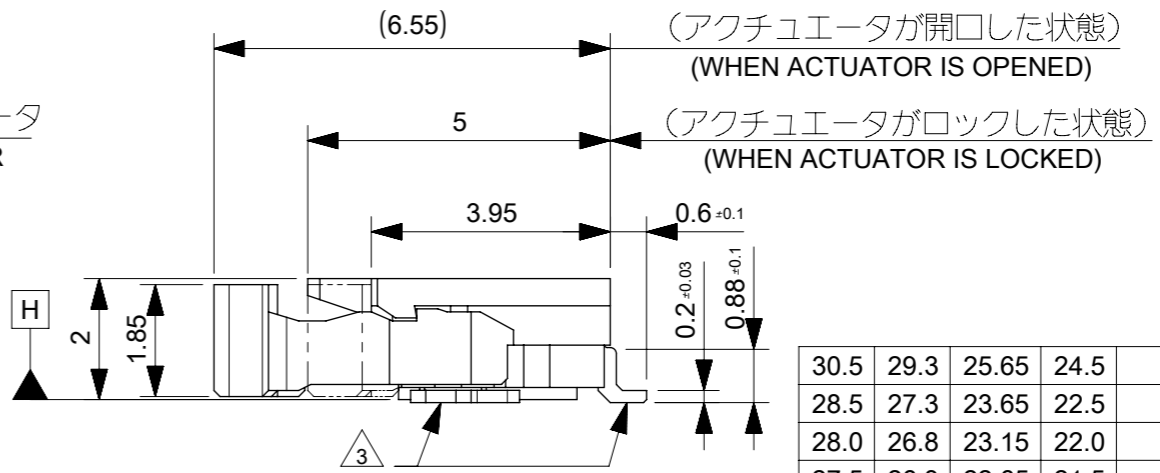
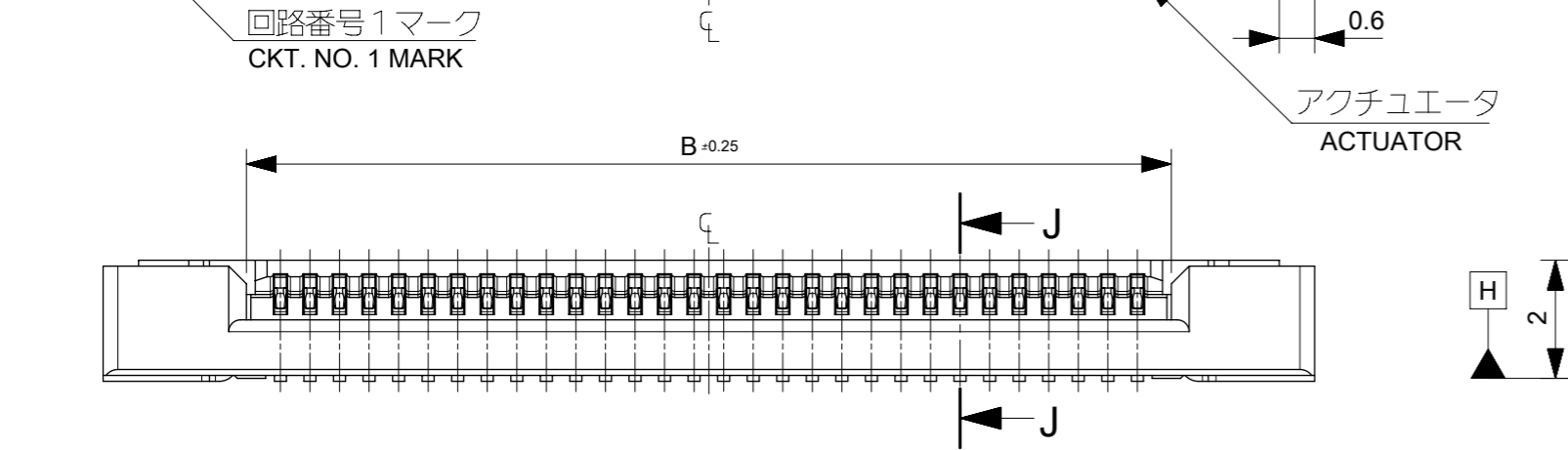
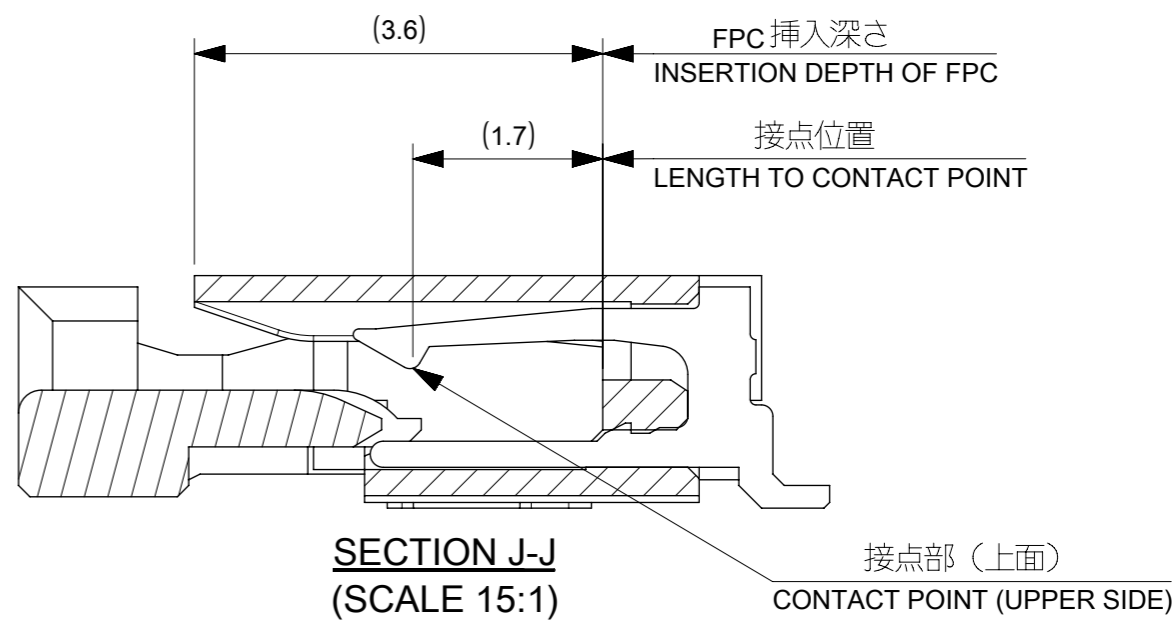
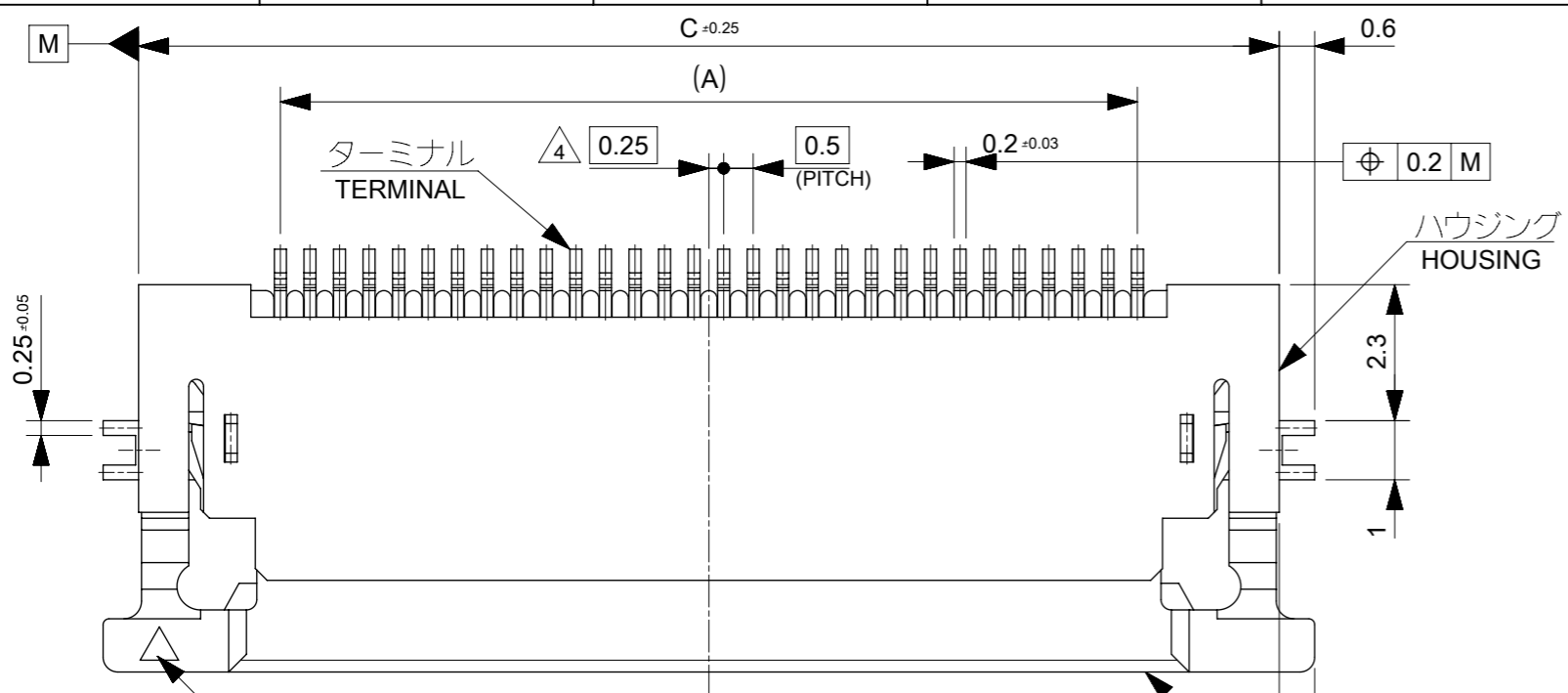

30.5	29.3	25.65	24.5	541045031	50
28.5	27.3	23.65	22.5	541044631	46
28.0	26.8	23.15	22.0	541044531	45
27.5	26.3	22.65	21.5	541044431	44
27.0	25.8	22.15	21.0	541044331	43
25.5	24.3	20.65	19.5	541044031	40
24.5	23.3	19.65	18.5	541043831	38
23.5	22.3	18.65	17.5	541043631	36
23.0	21.8	18.15	17.0	541043531	35
22.5	21.3	17.65	16.5	541043431	34
22.0	20.8	17.15	16.0	541043331	33
21.5	20.3	16.65	15.5	541043231	32
20.5	19.3	15.65	14.5	541043031	30
D	C	B	A	EMBOSSED PACKAGE ORDER NO. オーダー番号	CKT.
CONNECTOR SERIES NO. : 54104**29					

THIS DRAWING CONTAINS INFORMATION THAT IS PROPRIETARY TO MOLEX ELECTRONIC TECHNOLOGIES, LLC AND SHOULD NOT BE USED WITHOUT WRITTEN PERMISSION

2016/02/15	2016/05/23	2016/05/24	GENERAL TOLERANCES (UNLESS SPECIFIED)	DIMENSION UNITS	SCALE	molex [®]			
2016/02/15	2016/05/23	2016/05/24	ANGULAR TOL ± 3.0 °	MM	8:1				
EC NO: 103444 DRWN: ABABU01 CHK'D: YKOBAYASHI02 APPR: TKUSUHARA01	4 PLACES	±	DRWN BY	ABABU01	DATE	0.5 FPC CONN. ZIF SMT R/A UPPER CONTACT SEPARATED GOLD PLATING			
	3 PLACES	±	CHK'D BY	YKOBAYASHI02	DATE				
	2 PLACES	± 0.2	APPR BY	TKUSUHARA01	DATE	PRODUCT CUSTOMER DRAWING			
	1 PLACE	± 0.2	DRAWING SIZE	A3	THIRD ANGLE PROJECTION				
	0 PLACES	± 0.2	DRAFT WHERE APPLICABLE MUST REMAIN WITHIN DIMENSIONS						
RELEASE STATUS	P1	RELEASE DATE	24.05.2016	07:26:47	SERIES		MATERIAL NUMBER	CUSTOMER	
					54104	SEE CHART	GENERAL		
					DOCUMENT NUMBER	541041000	DOC TYPE	DOC PART	SHEET NUMBER
					PSD	000	1 OF 2		

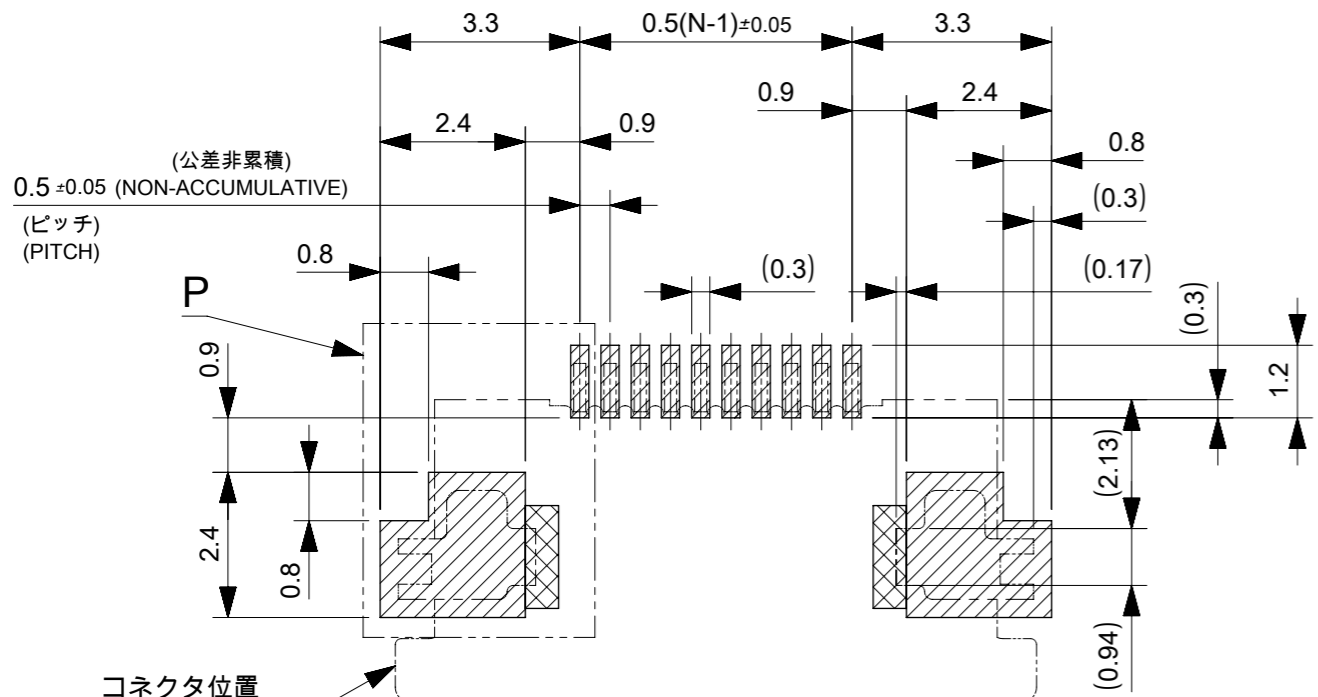

参考基板レイアウト
RECOMMENDED P.W.BOARD PATTERN DIMENSION(REF.)
(マウント面)
(MOUNTING SIDE)

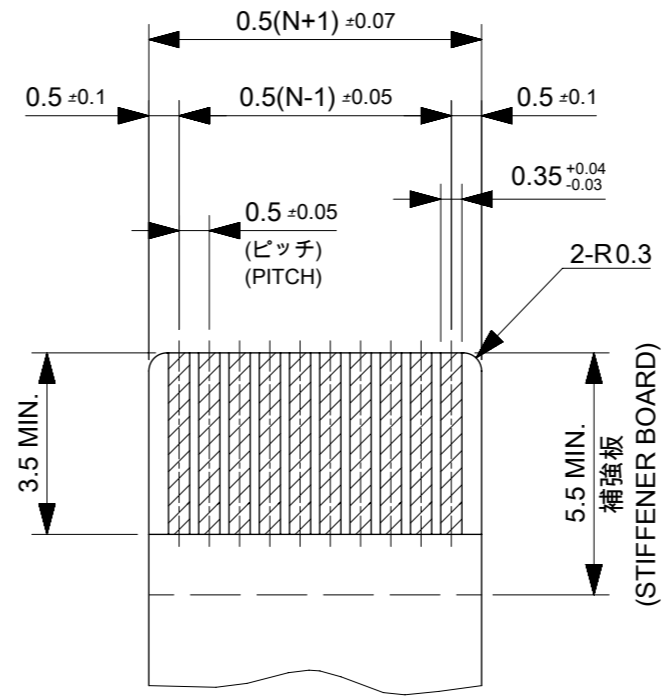

適合金めっき FPC 推奨寸法
APPLICABLE FPC OF GOLD PLATING
RECOMMENDED DIMENSION
(仕上がり厚さ : 0.3±0.03)
(THICKNESS : 0.3±0.03)

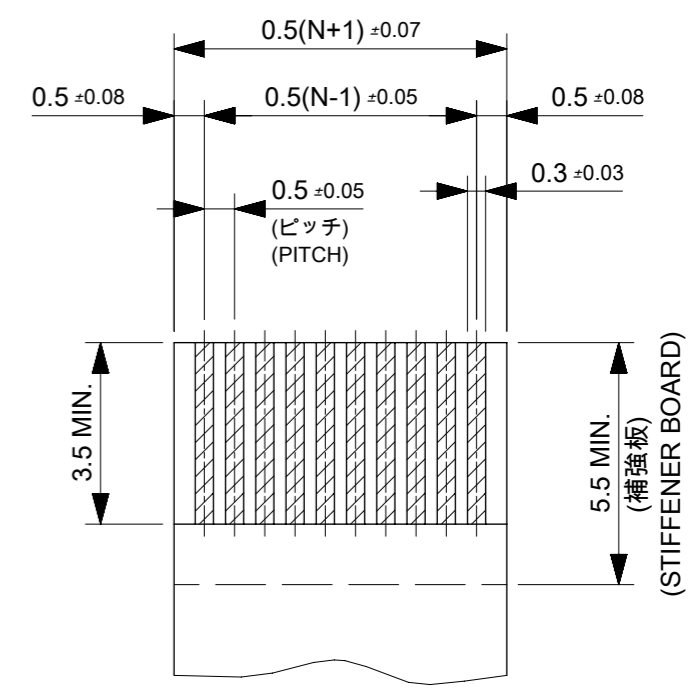

適合金めっき FFC 推奨寸法
APPLICABLE FFC OF GOLD PLATING
RECOMMENDED DIMENSION
(仕上がり厚さ : 0.3±0.03)
(THICKNESS : 0.3±0.03)

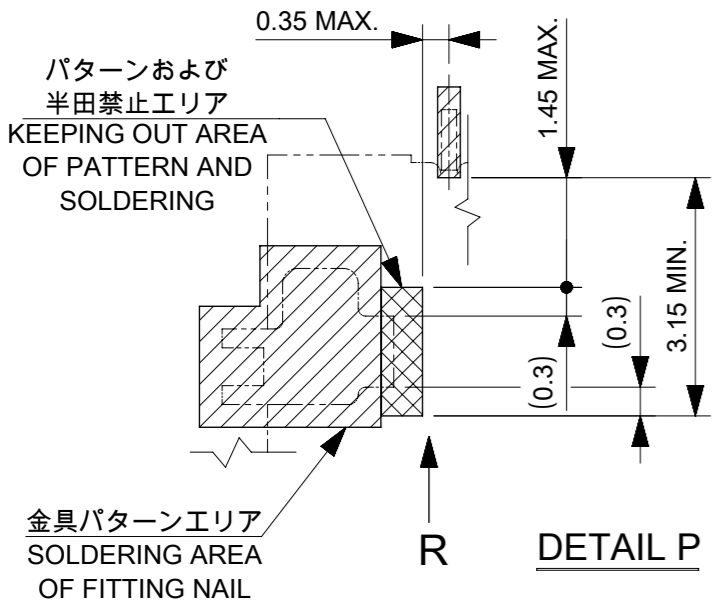

注記 NOTES

- 使用材料 MATERIAL
ハウジング : 46ナイロン、ガラス充填、UL94V-0、白
HOUSING : PA46, GLASS FILLED, UL94V-0, WHITE
アクチュエータ : ポリフェニレンサルファイド (PPS)、ガラス充填、UL94V-0、茶色
ACTUATOR : POLYPHENYLENE SULFIDE, GLASS FILLED, UL94V-0, BROWN
ターミナル : リン青銅(t=0.2) 金メッキ 0.1 MICROMETER MINIMUM
テール部 0.05 MICROMETER MINIMUM
ニッケル下地 1.0 MICROMETER MINIMUM
TERMINAL PHOS-BRONZE GOLD-PLATING
CONTACT PORTION : 0.1 MICROMETER MINIMUM
TAIL PORTION : 0.05 MICROMETER MINIMUM
NICKEL PLATING : 1.0 MICROMETER MINIMUM
金具 : リン青銅(t=0.2) 錫メッキ 1.0~3.0 MICROMETER MINIMUM
ニッケル下地 1.0~3.0 MICROMETER MINIMUM
FITTING NAIL : PHOS-BRONZE TIN-PLATING 1.0~3.0 MICROMETER MINIMUM
OVER NICKEL 1.0~3.0 MICROMETER MINIMUM
- エンボステーブ梱包時はアクチュエータがロックした状態とする。
IN THE PACKAGE, ACTUATOR OF PART NO.54104**29 SHOULD BE LOCKED.
ソルダーテール半田付け面のズレ量、および金具半田付け面のズレ量は
基準面 H に対し上方向 0.1MAXIMUM、下方向 0.15MAXIMUMとする。
MISALIGNMENT OF SOLDER TAILS AND FITTING NAILS FROM H
UPPER DIRECTION : 0.1MAXIMUM, LOWER DIRECTION : 0.15 MAXIMUM.

- 偶数極に適用。
APPLY FOR EVEN CIRCUIT.
- パターンはく離止め金具。
FITTING NAIL FOR PREVENTION OF PEELING OF P.W.BOARD PATTERN.
- ELV & RoHS適合品
ELV AND RoHS COMPLIANT

FPC/FFCについて:
打ち抜き方向は導体側から補強板側を推奨いたします。
導体部は軟銅箔 35MICROMETER または 50MICROMETERを推奨いたします。
RECOMMENDED PUNCHER DIRECTION
FROM CONDUCTOR SIDE TO STIFFENER BOARD SIDE.
RECOMMENDED CONDUCTOR SPEC
THICKNESS OF SOFT COPPER FOIL
: 35MICROMETERS OR 50MICROMETERS

FPCについて:
補強フィルム材質はポリイミドを推奨いたします。
接着剤は熱硬化接着剤を推奨いたします。
RECOMMENDED MATERIAL
STIFFENER FILM : POLYIMIDE
BONDING AGENT : THERMOSETTING BONDING AGENT

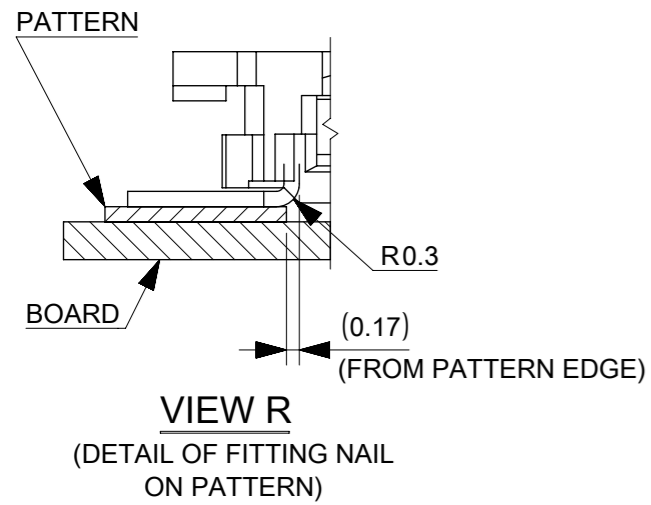

VIEW R
(DETAIL OF FITTING NAIL ON PATTERN)

THIS DRAWING CONTAINS INFORMATION THAT IS PROPRIETARY TO MOLEX ELECTRONIC TECHNOLOGIES, LLC AND SHOULD NOT BE USED WITHOUT WRITTEN PERMISSION

EC NO: 103444 DRWN: ABABU01 CHK'D: YKOBAYASHI02 APPR: TKUSUHARA01	2016/02/15	GENERAL TOLERANCES (UNLESS SPECIFIED)		DIMENSION UNITS	SCALE		
	2016/05/23	ANGULAR TOL ± 3.0 °		MM	1:1		
	2016/05/24	4 PLACES ±	DRWN BY	ABABU01	DATE		2016/02/15
		3 PLACES ±	CHK'D BY	YKOBAYASHI02	DATE		2016/05/23
	2 PLACES ± 0.2	APPR BY	TKUSUHARA01	DATE	2016/05/24	PRODUCT CUSTOMER DRAWING SERIES: 54104 MATERIAL NUMBER: SEE CHART CUSTOMER: GENERAL	
	1 PLACE ± 0.2	DRAWING SIZE	A3	THIRD ANGLE PROJECTION			
	0 PLACES ± 0.2	DRAFT WHERE APPLICABLE MUST REMAIN WITHIN DIMENSIONS					
RELEASE STATUS	P1	RELEASE DATE	24.05.2016	07:26:47	DOCUMENT NUMBER: 541041000 DOC TYPE: PSD DOC PART: 000 SHEET NUMBER: 2 OF 2		