

**注記 NOTES**

1. 使用材料 MATERIAL  
 ハウジング HOUSING : LCP , UL94V-0  
 アクチュエータ ACTUATOR : PA46 , UL94V-0  
 ターミナル : リン青銅 (t=0.12) , ニッケル下地 金メッキ  
 TERMINAL PHOSPHOR BRONZE, GOLD OVER NICKEL PLATING.  
 金具 : リン青銅 (t=0.2) , ニッケル下地 錫メッキ  
 STOPPER PHOSPHOR BRONZE, TIN OVER NICKEL PLATING.

△ ソルダーテール半田付け面のズレ量は、基準面 [R] に対し、  
 上方向 OMAX. 下方向 0.1 MAXIMUM とする。  
 又、相互のパラッキ量は 0.1 MAXIMUM とする。  
 MISALIGNMENT OF SOLDER TAILS AND FITTING NAILS FROM [R]  
 UPPER DIRECTION : 0 MAX., LOWER DIRECTION : 0.1 MAXIMUM  
 OFFSET BETWEEN SOLDER TAILS AND FITTING NAILS : 0.1 MAXIMUM

3. 一般公差 : ±0.3  
 GENERAL TOLERANCES : ±0.3

4. 本製品は 54809-\*\*67 の鉛フリー品である。  
 THIS PRODUCT IS LEAD FREE OF 54809-\*\*67.

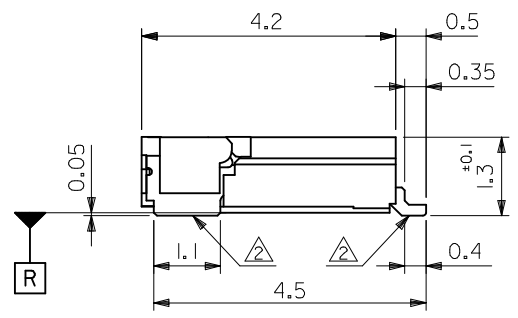

15.6	15.0	14.4	17.6	54809-5175	54809-5169	51
12.0	11.4	10.8	14.0	54809-3975	54809-3969	39
11.4	10.8	10.2	13.4	54809-3775	54809-3769	37
6.6	6.0	5.4	8.6	54809-2175	54809-2169	21
D	C	B	A	EMBOSSED TAPE		MATERIAL NO.
				ORDER No. オート番号		CIRCUITS

REVISED EC NO: J2014-1476 DRWN: AYOSHI 01 2014/03/31 CHKD: YKOBAYASHI 02 2014/03/31 APPR: YNOGAWA 2014/04/17	GENERAL TOLERANCES (UNLESS SPECIFIED)		DIMENSION STYLE MM ONLY		54809-**69 MODEL NO.	
	10 UNDER ±0.2		DRAWN BY TUENO DATE '04/02/10		SCALE --- DESIGN UNITS METRIC	
	10 OVER 30 UNDER ±0.25		CHECKED BY MSASAO DATE '04/02/10		THIRD ANGLE PROJECTION	
	30 OVER ±0.3		APPROVED BY MSASAO DATE '04/02/10		0.3 FPC CONN E/O HSG ASSY GOLD PLT H=1.3 -LEAD FREE-	
	ANGULAR ±3 °		MATERIAL NO. SEE TABLE		DOCUMENT NO. SD-54809-038	
DRAFT WHERE APPLICABLE MUST REMAIN WITHIN DIMENSIONS		SIZE A3		THIS DRAWING CONTAINS INFORMATION THAT IS PROPRIETARY TO MOLEX INCORPORATED AND SHOULD NOT BE USED WITHOUT WRITTEN PERMISSION		

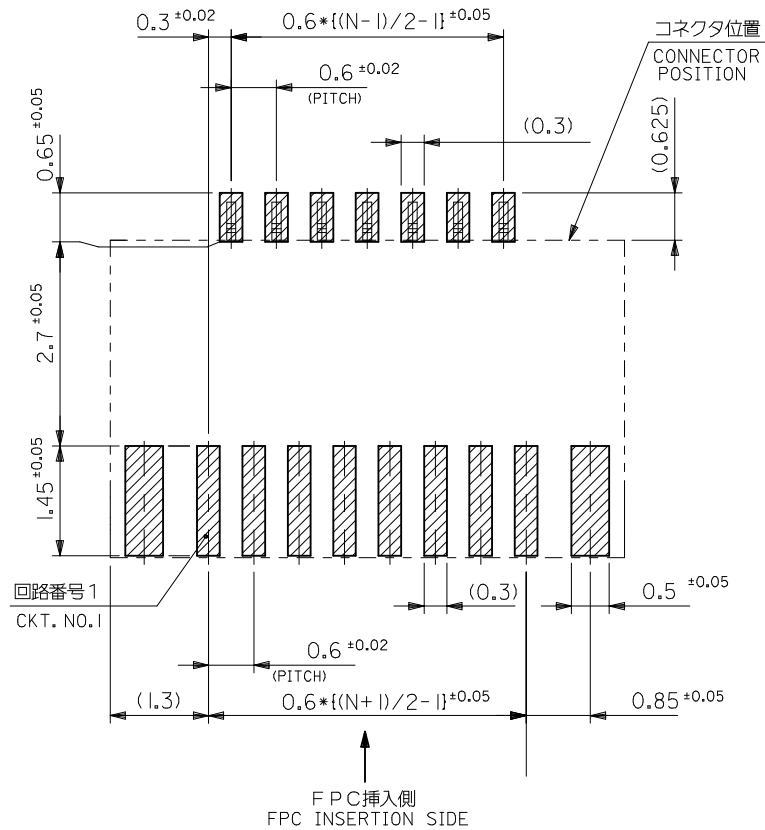

参考基板レイアウト  
RECOMMENDED P.C.BOARD  
PATTERN DIM. (REF.)  
(マウント面)  
(MOUNTING SIDE)

REVISED EC NO: J2014-1476 DRWN: YOSHI I 01 2014/03/31 CHKD: YKOBAYASHI 02 2014/03/31 APPR: YNOGAWA 2014/04/17	GENERAL TOLERANCES (UNLESS SPECIFIED)		DIMENSION STYLE MM ONLY		54809-***69		MODEL NO.	
	10 UNDER	±0.2	DRAWN BY	DATE	SCALE ---	DESIGN UNITS METRIC	THIRD ANGLE PROJECTION	
	10 OVER 30 UNDER	±0.25	TUENO	'04/02/10	TITLE 0.3 FPC CONN E/O HSG ASSY GOLD PLT H=1.3 -LEAD FREE-			
	30 OVER	±0.3	CHECKED BY	DATE	MATERIAL NO.			
	ANGULAR ±--- °	APPROVED BY	DATE	SEE SHEET 1		DOCUMENT NO.		SHEET NO.
	DRAFT WHERE APPLICABLE MUST REMAIN WITHIN DIMENSIONS	MSASAO	'04/02/10			SD-54809-038		2 OF 3
		THIS DRAWING CONTAINS INFORMATION THAT IS PROPRIETARY TO MOLEX INCORPORATED AND SHOULD NOT BE USED WITHOUT WRITTEN PERMISSION						

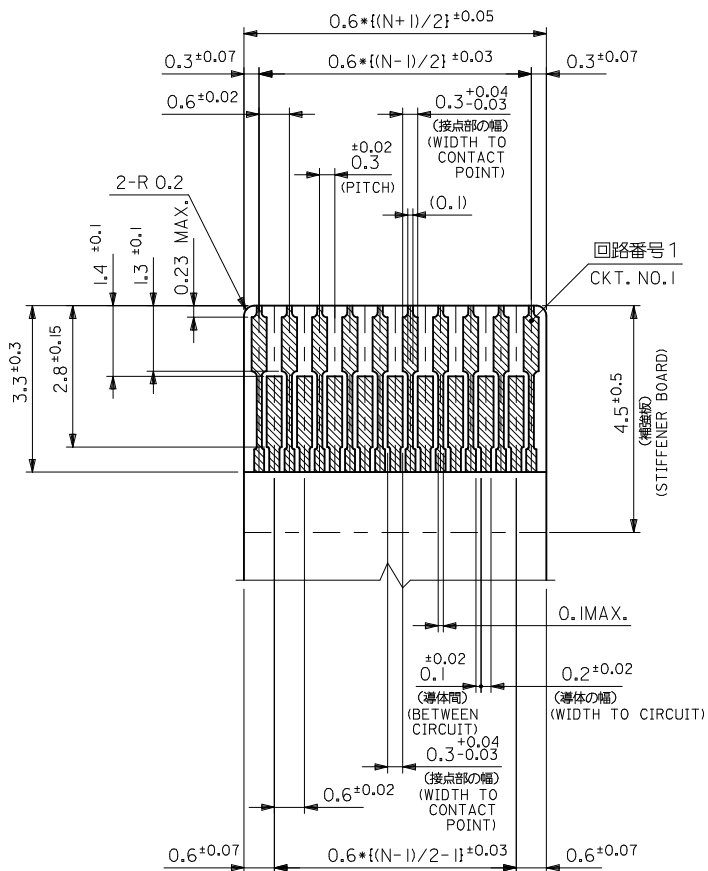

適合FPC推奨寸法 1  
 APPLICABLE FPC  
 RECOMMENDED DIM. NO.1  
 (仕上がり厚さ: 0.2 ± 0.03)  
 (THICKNESS : 0.2 ± 0.03)

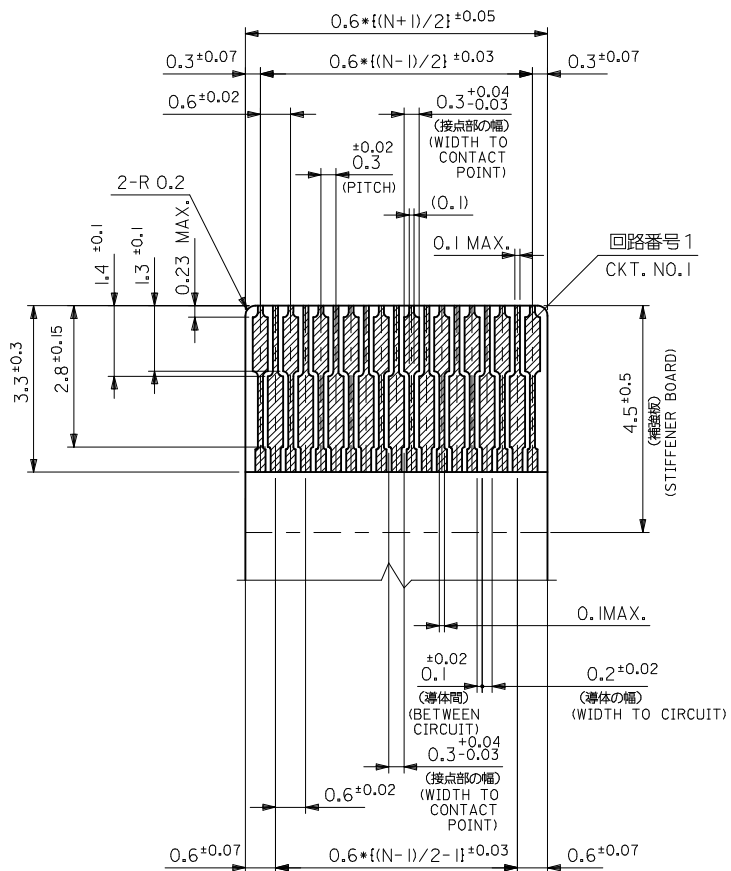

適合FPC推奨寸法 2  
 APPLICABLE FPC  
 RECOMMENDED DIM. NO.2  
 (仕上がり厚さ: 0.2 ± 0.03)  
 (THICKNESS : 0.2 ± 0.03)

FPCについて:  
 打抜き方向は導体側から補強板側を推奨致します。  
 補強フィルム材質はポリイミドを推奨致します。  
 接着剤は熱硬化接着剤を推奨致します。

ABOUT FPC :  
 RECOMMENDED PUNCHER DIRECTION :  
 FROM CONDUCTOR SIDE TO STIFFENER BOARD SIDE.  
 RECOMMENDED MATERIAL :  
 STIFFENER FILM : POLYIMIDE  
 BONDING AGENT : THERMOSETTING BONDING AGENT

REVISED EC NO: J2014-1476 DRWN:AYOSHI 2014/03/31 CHKD:YKOBAYASHI 2014/03/31 APPR:YNOGAWA 2014/04/17	GENERAL TOLERANCES (UNLESS SPECIFIED)		DIMENSION STYLE MM ONLY		54809-***69	MODEL NO.
	10 UNDER	± 0.2	DRAWN BY	DATE	SCALE ---	DESIGN UNITS METRIC
	10 OVER 30 UNDER	± 0.25	YSAKIYAM	'04/06/15	THIRD ANGLE PROJECTION	
	30 OVER	± 0.3	CHECKED BY	DATE	TITLE	
	ANGULAR ± 3 °	MSASAO	'04/06/15	0.3 FPC CONN E/O HSG ASSY GOLD PLT H=1.3 -LEAD FREE-		
	DRAFT WHERE APPLICABLE MUST REMAIN WITHIN DIMENSIONS	MATERIAL NO.	SEE SHEET 1		DOCUMENT NO. SD-54809-038	
		SIZE A3	THIS DRAWING CONTAINS INFORMATION THAT IS PROPRIETARY TO MOLEX INCORPORATED AND SHOULD NOT BE USED WITHOUT WRITTEN PERMISSION			

引き出し方向  
PULL OUT

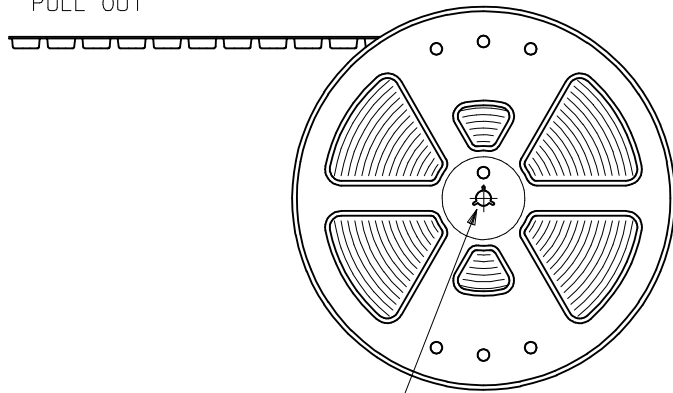

"F"

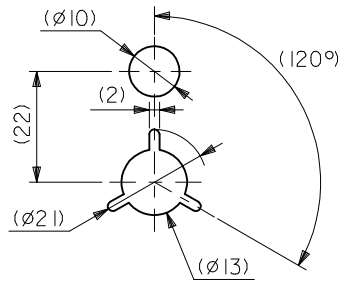

DETAIL "F"

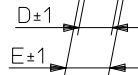
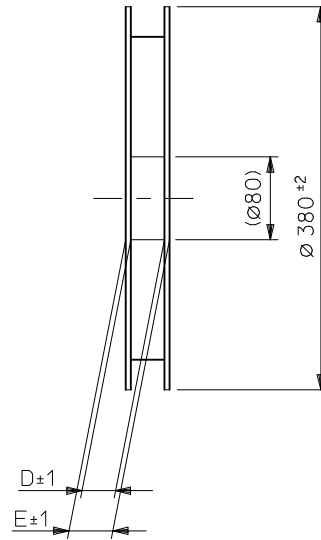

**注記 NOTES**

- 製品詳細寸法については、図面SD-54809-038を参照下さい。  
RE DETAILED DIMENSION, SEE SD-54809-038.
- 梱包数量：2500個/リール  
NUMBER OF CONNECTORS : 2500PCS/REEL
- リードテープ長さ LEAD TAPE LENGTH

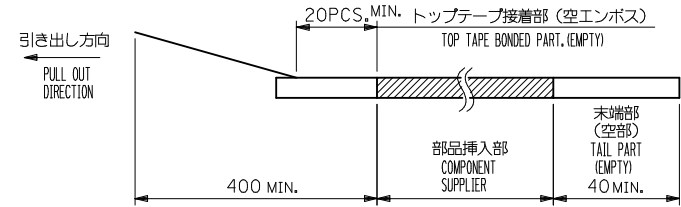

- トップテープの剥離強度：0.1N~1.3N (10gf~130gf)  
(剥離方向は下図参照)  
尚、本規格値は出荷時に適用。(但し、輸送時に剥離が発生しないこと。)  
PEELING OFF FORCE OF TOP TAPE : 0.1N~1.3N(10gf~130gf)  
(PEELING DIRECTION AS SHOWN IN FOLLOWING FIG.)  
THIS REQUIREMENT SHOULD BE APPLIED AT SHIPMENT.  
PEEL OFF SHOULD NOT BE ALLOWED, DURING TRANSPORTATION.

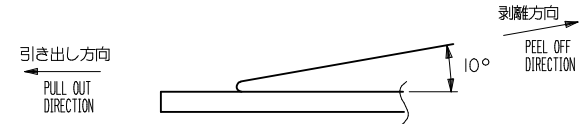

- 材料 (MATERIAL)  
キャリアテープ (CARRIER TAPE) : ポリプロピレン (POLYPROPYLENE)  
トップテープ (TOP TAPE) : PET, PE, PEF  
リール (REEL) : ポリスチレン (PS) <リサイクル材を含む>  
POLYSTYRENE(PS) <RECYCLE MATERIAL CONTAINED>
- 本製品は 54809-\*\*95 の鉛フリー品である。  
THIS PRODUCT IS LEAD FREE OF 54809-\*\*95.

REVISED EC NO: J2014-1476 DRWN:AYOSHI 01 2014/03/31 CHKD:YKOBAYASHI 02 2014/03/31 APPR:YNOGAWA 2014/04/17	GENERAL TOLERANCES (UNLESS SPECIFIED)		DIMENSION STYLE MM ONLY		54809-**75 SCALE --- DESIGN UNITS METRIC		MODEL NO. THIRD ANGLE PROJECTION	
	10 UNDER	±0.2	DRAWN BY	DATE	TITLE EMBSTP PKG FOR 0.3 FPC CONN E/O GOLD PLT H=1.3 -LEAD FREE- <b>molex</b>			
	10 OVER 30 UNDER	±0.25	TUENO	'04/02/10				
	30 OVER	±0.3	CHECKED BY	DATE	DOCUMENT NO. SD-54809-039 SHEET NO. 1 OF 4			
ANGULAR	±3 °	MSASAO	'04/02/10					
DRAFT WHERE APPLICABLE MUST REMAIN WITHIN DIMENSIONS		MATERIAL NO. SEE CHART		THIS DRAWING CONTAINS INFORMATION THAT IS PROPRIETARY TO MOLEX INCORPORATED AND SHOULD NOT BE USED WITHOUT WRITTEN PERMISSION				

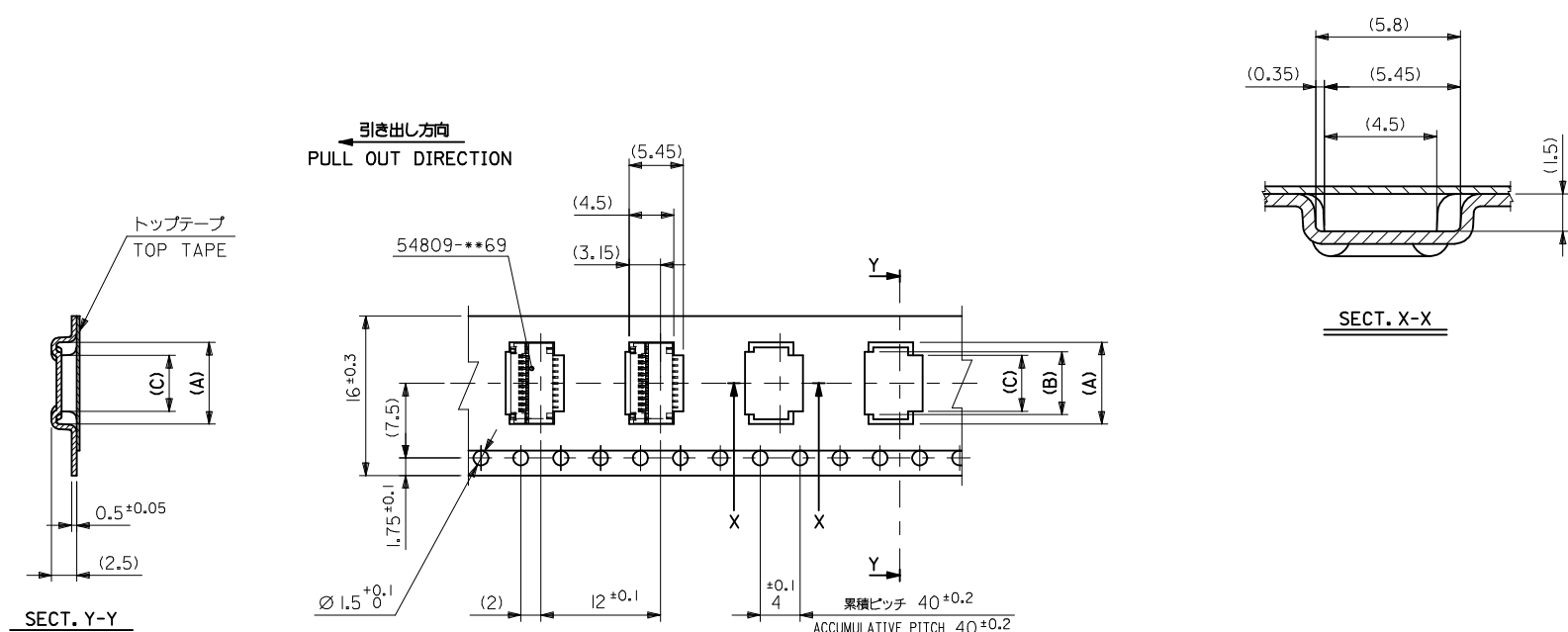

**16mm幅キャリアテープ**  
16mm WIDTH CARRIER TAPE

16	21.4	17.4	6.2	6.9	8.8	54809-2175	21
キャリアテープ幅 CARRIER TAPE WIDTH	E	D	C	B	A	MATERIAL NO.	種数 CKT.

REVISED EC NO: J2014-1476 DRWN: AYOSHI 2014/03/31 CHKD: YKOBAYASHI 02 2014/03/31 APPR: YNOGAWA 2014/04/17	DESCRIPTION REV	GENERAL TOLERANCES (UNLESS SPECIFIED)		DIMENSION STYLE MM ONLY		54809-***75 SCALE --- DESIGN UNITS METRIC		MODEL NO.		
		10 UNDER	±0.2	DRAWN BY	DATE	TITLE				
		10 OVER 30 UNDER	±0.25	TUENO	'04/02/10	EMBSTP PKG FOR 0.3 FPC CONN E/O GOLD PLT H=1.3 -LEAD FREE-				
		30 OVER	±0.3	CHECKED BY	DATE	<b>molex</b>				
ANGULAR ±3 ° DRAFT WHERE APPLICABLE MUST REMAIN WITHIN DIMENSIONS		APPROVED BY MSASAO '04/02/10		MATERIAL NO. SEE CHRAT		DOCUMENT NO. SD-54809-039		SHEET NO. 2 OF 4		
SIZE A3		THIS DRAWING CONTAINS INFORMATION THAT IS PROPRIETARY TO MOLEX INCORPORATED AND SHOULD NOT BE USED WITHOUT WRITTEN PERMISSION								

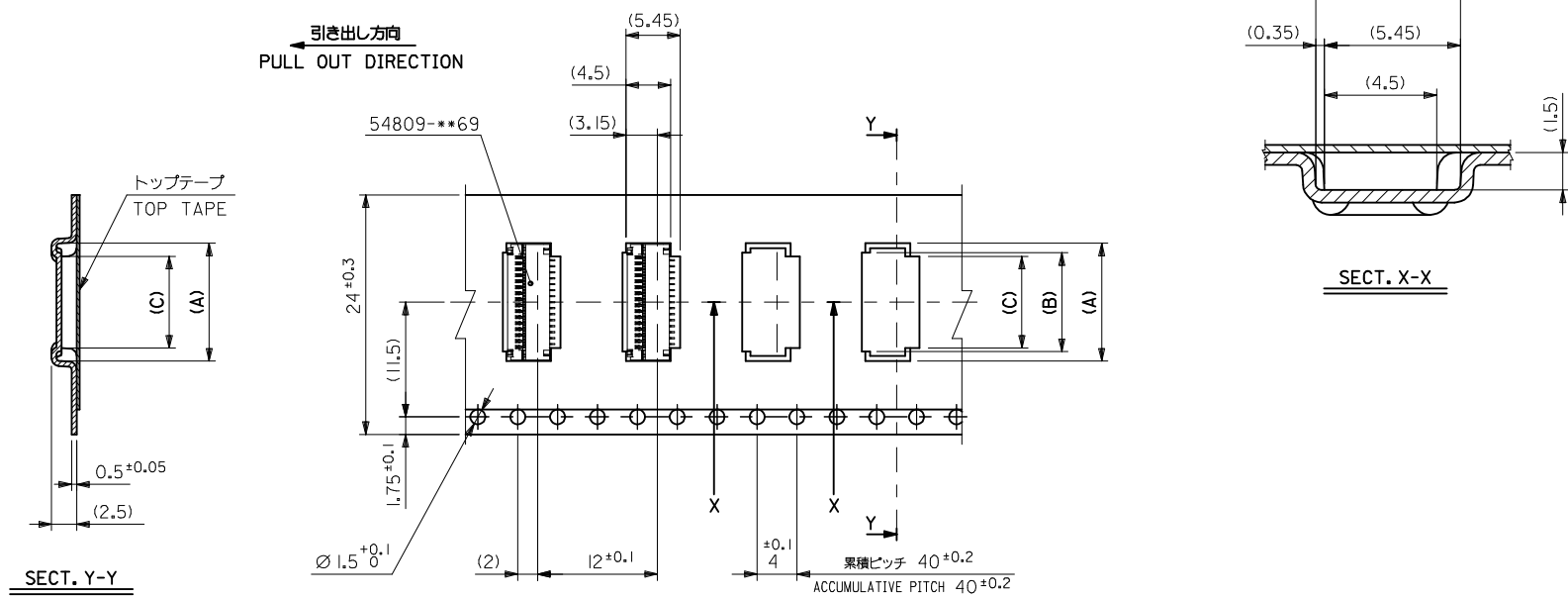

24mm幅キャリアテープ  
24mm WIDTH CARRIER TAPE

24	29.4	25.4	11.6	12.3	14.2	54809-3975	39
キャリアテープ幅 CARRIER TAPE WIDTH	E	D	C	B	A	54809-3775	37
						MATERIAL NO.	種数 CKT.

REVISED EC NO: J2014-1476 DRWN: YOSHII 2014/03/31 CHKD: YKOBAYASHI 02 2014/03/31 APPR: YNOGAWA 2014/04/17	DESCRIPTION	GENERAL TOLERANCES (UNLESS SPECIFIED)	DIMENSION STYLE	SCALE	DESIGN UNITS	MODEL NO.	
	REV	10 UNDER ±0.2	MM ONLY	---	METRIC	54809-***75	
		10 OVER 30 UNDER ±0.25				THIRD ANGLE PROJECTION	
		30 OVER ±0.3					
		ANGULAR ±3 °					
		DRAFT WHERE APPLICABLE MUST REMAIN WITHIN DIMENSIONS					
			DRAWN BY	DATE	TITLE		
			TUENO	'04/02/10	EMBSTP PKG FOR 0.3 FPC CONN E/O GOLD PLT H=1.3 -LEAD FREE-		
			CHECKED BY	DATE			
			MSASAO	'04/02/10			
			APPROVED BY	DATE			
			MSASAO	'04/02/10			
			MATERIAL NO.	DOCUMENT NO.			
			SEE CAHRT				
			SIZE				
			A3				
			THIS DRAWING CONTAINS INFORMATION THAT IS PROPRIETARY TO MOLEX INCORPORATED AND SHOULD NOT BE USED WITHOUT WRITTEN PERMISSION				

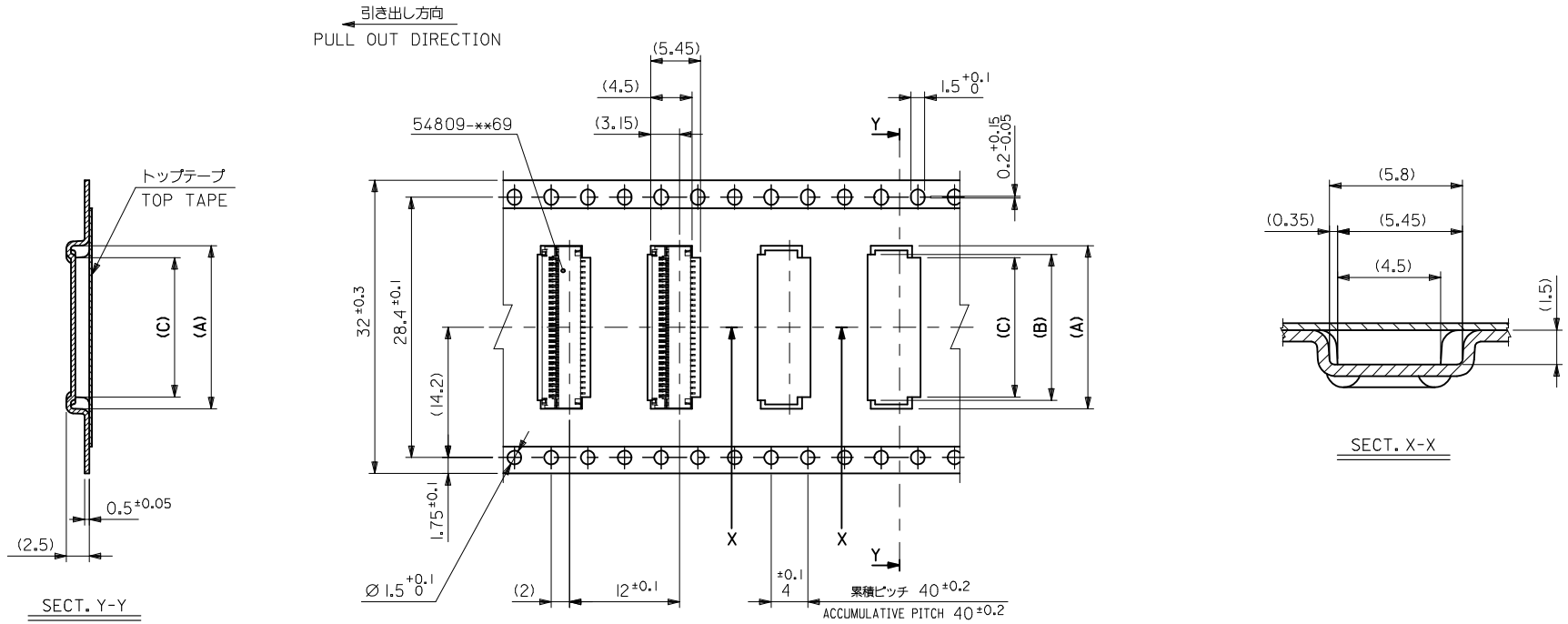

32mm幅キャリアテープ  
32mm WIDTH CARRIER TAPE

32	37.4	33.4	15.2	15.9	17.8	54809-5175	51
キャリアテープ幅 CARRIER TAPE WIDTH	E	D	C	B	A	MATERIAL NO.	極致 CIRCUITS

REVISED EC NO: J2014-1476 DRWN: YOSHI I 2014/03/31 CHKD: YOSHIMOTO 2014/03/31 APPR: YOGAWA 2014/04/17	GENERAL TOLERANCES (UNLESS SPECIFIED)		DIMENSION STYLE MM ONLY		SCALE ---	DESIGN UNITS METRIC	THIRD ANGLE PROJECTION
	10 UNDER	±0.2	DRAWN BY TUENO	DATE '04/02/10	TITLE EMBSTP PKG FOR 0.3 FPC CONN E/O GOLD PLT H=1.3 -LEAD FREE-		
	10 OVER 30 UNDER	±0.25	CHECKED BY MSASAO	DATE '04/02/10	<b>molex</b> DOCUMENT NO. SD-54809-039 SHEET NO. 4 OF 4		
	30 OVER	±0.3	APPROVED BY MSASAO	DATE '04/02/10			
	ANGULAR ±3 °	MATERIAL NO. SEE CHART		MATERIAL NO. SD-54809-039			
	DRAFT WHERE APPLICABLE MUST REMAIN WITHIN DIMENSIONS	THIS DRAWING CONTAINS INFORMATION THAT IS PROPRIETARY TO MOLEX INCORPORATED AND SHOULD NOT BE USED WITHOUT WRITTEN PERMISSION					