

CIRCUIT SIZE	DIM. "A"	DIM. "B"
2	.21 (5.4)	—
4	.38 (9.6)	.17 (4.2)
6	.54 (13.8)	.33 (8.4)
8	.71 (18.0)	.50 (12.6)
10	.87 (22.2)	.66 (16.8)
12	1.04 (26.4)	.83 (21.0)
14	1.20 (30.6)	.99 (25.2)
16	1.37 (34.8)	1.16 (29.4)
18	1.54 (39.0)	1.32 (33.6)
20	1.70 (43.2)	1.49 (37.8)
22	1.87 (47.4)	1.65 (42.0)
24	2.03 (51.6)	1.82 (46.2)

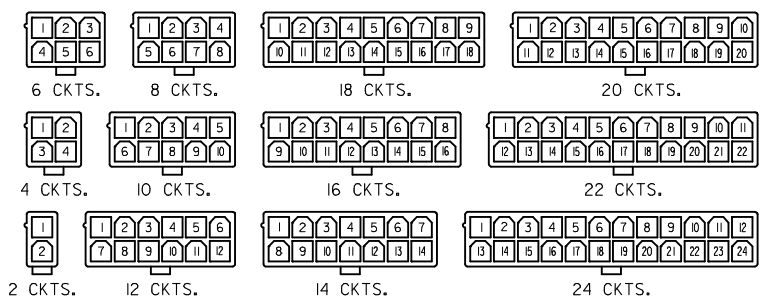

CIRCUIT SIZE LAYOUT

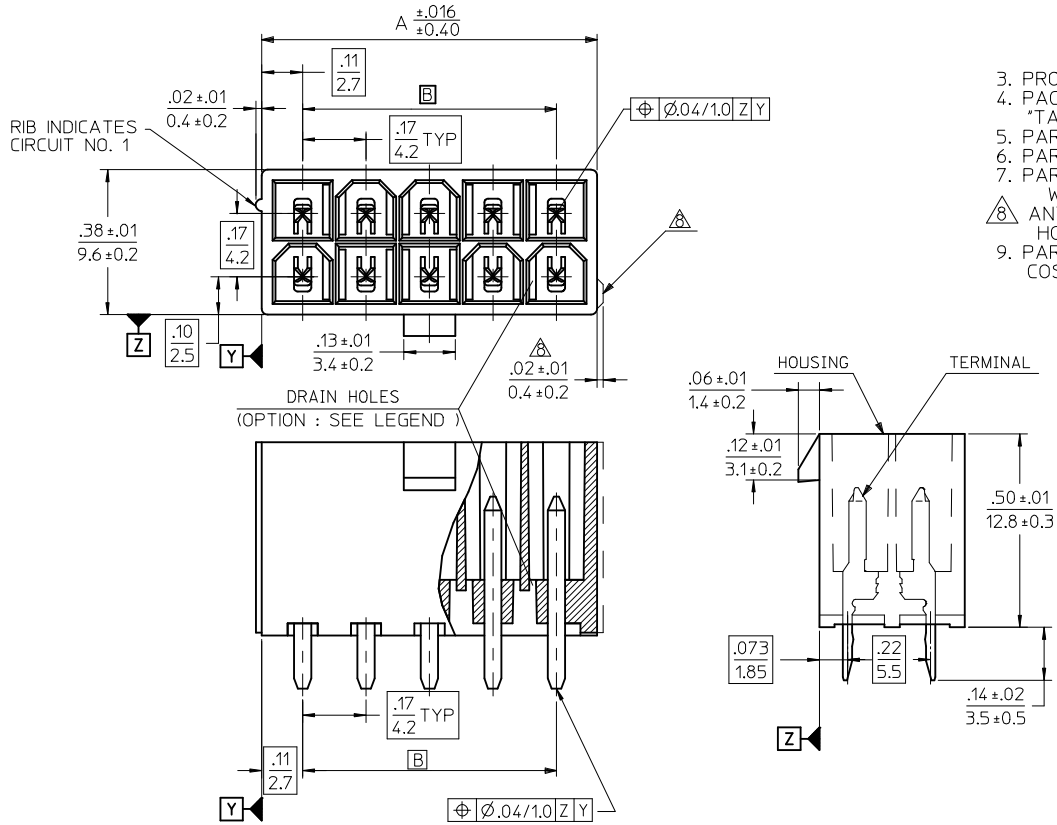

DRAIN HOLES
(OPTION : SEE LEGEND)

LEGEND

5566 - N * * * * - - - *

BASE NUMBER

CIRCUIT SIZE

ASSY TYPE
A : WITHOUT DRAIN HOLES
B : WITH DRAIN HOLES

TERMINAL MATERIAL
SEE NOTE 1

TERMINAL PLATING
SEE NOTE 2

HOUSING MATERIAL
SEE NOTE 1

COLOR OR PACKAGING
BL : BLACK RE : RED GR : GRAY
BU : BLUE YE : YELLOW GRE : GREEN
V : VIOLET OR : ORANGE
TA : TRAY PACKAGING SEE NOTE 4
TR : TRAY PACKAGING SEE NOTE 4

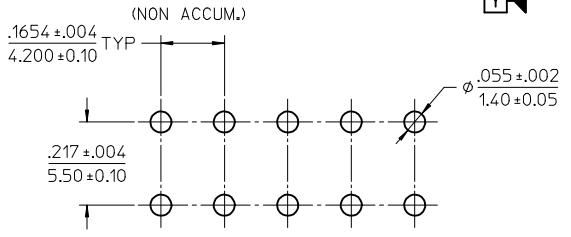

RECOMMENDED HOLE LAYOUT FOR
.070(1.78) MAX. THICK P.C. BOARD
VIEWED FROM COMPONENT SIDE

ADD P/N'S EC NO: UCP2014-2112 DRAWN: NGUYEN CHKD: J.BELL APPR: FSMITH	REV L7	DESCRIPTION 2013/11/13 2013/11/13 2013/11/27	QUALITY SYMBOLS ▽=0 ▽=0 ▽=0	GENERAL TOLERANCES (UNLESS SPECIFIED)		DIMENSION STYLE IN/MM		SCALE 4:1	DESIGN UNITS METRIC	THIRD ANGLE PROJECTION
				mm	INCH	DRAWN BY H.HIRAMOTO	DATE '89/04/03	MINI FIT JR VERTICAL HEADER ASSEMBLIES WITHOUT PEGS		
				4 PLACES ± ---	± ---	CHECKED BY M.FUKUSHIMA	DATE '94/04/20			
DRAFT WHERE APPLICABLE MUST REMAIN WITHIN DIMENSIONS				ANGULAR ± 3 °		APPROVED BY FSMITH		DATE 2012/05/04	MATERIAL NO. SEE TABLE	
						DOCUMENT NO. SD-5566-002		SHEET NO. 1 OF 5		

- NOTES:
- MATERIALS:
HOUSING:
"BLANK"=NYLON 6/6, UL94V-2, COLOR: NATURAL
"210" =NYLON 6/6, UL94V-0, COLOR: NATURAL
"400"=NYLON 6/6, UL94V-0, COLOR: BLACK
TERMINALS:
"BLANK" = BRASS
"PB" = PHOSPHOR BRONZE
2. TERMINAL PLATING:
"BLANK" = BRIGHT TIN 0.00035/(0.00090) MIN.
OVER COPPER .000020/(0.00050) MIN. (BRASS)
TIN .000035/(0.00090) MIN. REFLOW TREATMENT
OR BRIGHT TIN .000035/(0.00090) MIN. (PHOSPHOR BRONZE)
"S"=.000100/(0.00254) MIN. BRIGHT TIN OVER
.000050/(0.00127) MIN NICKEL
"GS2"=.000015/(0.00038) MIN. SELECT GOLD AND
.000100/(0.00254) MIN. SELECT MATTE TIN
OVER .000050/(0.00127) MIN. NICKEL OVERALL
"GS"=.000030/(0.00076) MIN. SELECT GOLD AND
.000100/(0.00254) MIN. SELECT MATTE TIN
OVER .000050/(0.00127) MIN. NICKEL OVERALL
3. PRODUCT SPECIFICATION: PS-5556-001
4. PACKAGING: "BLANK"= BULK PACKED,
"TA"=TRAY PACK PER PK-5566-001, "TR"=TRAY PACK PER PK-5566
5. PART MATES WITH MINI-FIT JR. RECEPTACLE NO. 5557.
6. PART IS NOT DESIGNED FOR CURRENT SHARING.
7. PARTS ARE NOT DESIGNED TO BE MATED OR UN-MATED
WHILE CIRCUITS ARE LIVE.
8. ANTI-SHINGLING RIB MAY OR MAY NOT APPEAR ON
HOUSINGS.
9. PART CONFORMS TO CLASS "B" REQUIREMENTS OF
COSMETIC SPECIFICATION PS-45499-002.

13	12	11	10	9	8	7	6	5	4	3	2	1
39-29-5247	5566-24APB-2 IO	39-30-9245	5566-24AGS2-2 IO	39-29-6248	5566-24AGS-2 IO	39-30-6242	5566-24AS-2 IO	39-28-8240	5566-24A-2 IO			
▲ -5227	▲ -22APB-2 IO	▲ -9225	▲ -22AGS2-2 IO	▲ -6228	▲ -22AGS-2 IO	▲ -6222	▲ -22AS-2 IO	▲ -8220	▲ -22A-2 IO			
-5207	-20APB-2 IO	-9205	-20AGS2-2 IO	-6208	-20AGS-2 IO	-6202	-20AS-2 IO	-8200	-20A-2 IO			
-5187	-18APB-2 IO	-9185	-18AGS2-2 IO	-6188	-18AGS-2 IO	-6182	-18AS-2 IO	-8180	-18A-2 IO			
-5167	-16APB-2 IO	-9165	-16AGS2-2 IO	-6168	-16AGS-2 IO	-6162	-16AS-2 IO	-8160	-16A-2 IO			
-5147	-14APB-2 IO	-9145	-14AGS2-2 IO	-6148	-14AGS-2 IO	-6142	-14AS-2 IO	-8140	-14A-2 IO			
-5127	-12APB-2 IO	-9125	-12AGS2-2 IO	-6128	-12AGS-2 IO	-6122	-12AS-2 IO	-8120	-12A-2 IO			
-5107	-10APB-2 IO	-9105	-10AGS2-2 IO	-6108	-10AGS-2 IO	-6102	-10AS-2 IO	-8100	-10A-2 IO			
-5087	-08APB-2 IO	-9085	-08AGS2-2 IO	-6088	-08AGS-2 IO	-6082	-08AS-2 IO	-8080	-08A-2 IO			
-5067	-06APB-2 IO	-9065	-06AGS2-2 IO	-6068	-06AGS-2 IO	-6062	-06AS-2 IO	-8060	-06A-2 IO			
▼ -5047	▼ -04APB-2 IO	▼ -9045	▼ -04AGS2-2 IO	▼ -6048	▼ -04AGS-2 IO	▼ -6042	▼ -04AS-2 IO	▼ -8040	▼ -04A-2 IO			
39-29-5027	5566-02APB-2 IO	39-30-9025	5566-02AGS2-2 IO	39-29-6028	5566-02AGS-2 IO	39-30-6022	5566-02AS-2 IO	39-28-8020	5566-02A-2 IO			
EDP NO.	ENG. NO.	EDP NO.	ENG. NO.	EDP NO.	ENG. NO.	EDP NO.	ENG. NO.	EDP NO.	ENG. NO.			
5566-NAPB-2 IO		5566-NAGS2-2 IO		5566-NAGS-2 IO		5566-NAS-2 IO		5566-NA-2 IO				
39-29-5246	5566-24APB	39-30-9244	5566-24AGS2	39-29-0243	5566-24AGS	39-30-6241	5566-24AS	39-28-1243	5566-24A			
▲ -5226	▲ -22APB	▲ -9224	▲ -22AGS2	▲ -0223	▲ -22AGS	▲ -6221	▲ -22AS	▲ -1223	▲ -22A			
-5206	-20APB	-9204	-20AGS2	-0203	-20AGS	-6201	-20AS	-1203	-20A			
-5186	-18APB	-9184	-18AGS2	-0183	-18AGS	-6181	-18AS	-1183	-18A			
-5166	-16APB	-9164	-16AGS2	-0163	-16AGS	-6161	-16AS	-1163	-16A			
-5146	-14APB	-9144	-14AGS2	-0143	-14AGS	-6141	-14AS	-1143	-14A			
-5126	-12APB	-9124	-12AGS2	-0123	-12AGS	-6121	-12AS	-1123	-12A			
-5106	-10APB	-9104	-10AGS2	-0103	-10AGS	-6101	-10AS	-1103	-10A			
-5086	-08APB	-9084	-08AGS2	-0083	-08AGS	-6081	-08AS	-1083	-08A			
-5066	-06APB	-9064	-06AGS2	-0063	-06AGS	-6061	-06AS	-1063	-06A			
▼ -5046	▼ -04APB	▼ -9044	▼ -04AGS2	▼ -0043	▼ -04AGS	▼ -6041	▼ -04AS	▼ -1043	▼ -04A			
39-29-5026	5566-02APB	39-30-9024	5566-02AGS2	39-29-0023	5566-02AGS	39-30-6021	5566-02AS	39-28-1023	5566-02A			
EDP NO.	ENG. NO.	EDP NO.	ENG. NO.	EDP NO.	ENG. NO.	EDP NO.	ENG. NO.	EDP NO.	ENG. NO.			
5566-NAPB		5566-NAGS2		5566-NAGS		5566-NAS		5566-NA				
										CKT. SIZE		

PARTS WITH OUT DRAIN HOLES

SEE SHEET 1 EC NO: UCP2014-2112 DRAWN: NGUYEN 2013/11/13 CHKD: BELL 2013/11/13 APPR: FSMITH 2013/11/27 L7	QUALITY SYMBOLS ▽=0 ▽=0 ▽=0	GENERAL TOLERANCES (UNLESS SPECIFIED) <table border="1"> <tr> <th></th> <th>mm</th> <th>INCH</th> </tr> <tr> <td>4 PLACES</td> <td>± .005</td> <td>± .0005</td> </tr> <tr> <td>3 PLACES</td> <td>± .005</td> <td>± .0005</td> </tr> <tr> <td>2 PLACES</td> <td>± .13</td> <td>± .010</td> </tr> <tr> <td>1 PLACE</td> <td>± .25</td> <td>± .010</td> </tr> </table>		mm	INCH	4 PLACES	± .005	± .0005	3 PLACES	± .005	± .0005	2 PLACES	± .13	± .010	1 PLACE	± .25	± .010	DIMENSION STYLE IN/MM DRAWN BY: H. HIRAMOTO DATE: '89/04/03 CHECKED BY: M. FUKUSHIMA DATE: '94/04/20 APPROVED BY: FSMITH DATE: 2012/05/04	SCALE: 1:1 DESIGN UNITS: METRIC THIRD ANGLE PROJECTION	TITLE: MINI FIT JR VERTICAL HEADER ASSEMBLIES WITHOUT PEGS MOLEX MOLEX INCORPORATED MATERIAL NO. SEE TABLE DOCUMENT NO. SD-5566-002	SHEET NO. 2 OF 5
		mm	INCH																		
	4 PLACES	± .005	± .0005																		
	3 PLACES	± .005	± .0005																		
2 PLACES	± .13	± .010																			
1 PLACE	± .25	± .010																			
DRAFT WHERE APPLICABLE MUST REMAIN WITHIN DIMENSIONS		THIS DRAWING CONTAINS INFORMATION THAT IS PROPRIETARY TO MOLEX INCORPORATED AND SHOULD NOT BE USED WITHOUT WRITTEN PERMISSION																			

13	12	11	10	9	8	7	6	5	4	3	2	1
39-30-9247	5566-24BGS2-2 I0	39-31-0248	5566-24BGS-2 I0	39-31-0242	5566-24BS-2 I0	39-31-0240	5566-24B-2 I0	39-30-6244	5566-24APBS-2 I0	24		
▲ -9227	▲ -22BGS2-2 I0	▲ -0228	▲ -22BGS-2 I0	▲ -0222	▲ -22BS-2 I0	▲ -0220	▲ -22B-2 I0	▲ -6224	▲ -22APBS-2 I0	22		
-9207	-20BGS2-2 I0	-0208	-20BGS-2 I0	-0202	-20BS-2 I0	-0200	-20B-2 I0	-6204	-20APBS-2 I0	20		
-9187	-18BGS2-2 I0	-0188	-18BGS-2 I0	-0182	-18BS-2 I0	-0180	-18B-2 I0	-6184	-18APBS-2 I0	18		
-9167	-16BGS2-2 I0	-0168	-16BGS-2 I0	-0162	-16BS-2 I0	-0160	-16B-2 I0	-6164	-16APBS-2 I0	16		
-9147	-14BGS2-2 I0	-0148	-14BGS-2 I0	-0142	-14BS-2 I0	-0140	-14B-2 I0	-6144	-14APBS-2 I0	14		
-9127	-12BGS2-2 I0	-0128	-12BGS-2 I0	-0122	-12BS-2 I0	-0120	-12B-2 I0	-6124	-12APBS-2 I0	12		
-9107	-10BGS2-2 I0	-0108	-10BGS-2 I0	-0102	-10BS-2 I0	-0100	-10B-2 I0	-6104	-10APBS-2 I0	10		
-9087	-08BGS2-2 I0	-0088	-08BGS-2 I0	-0082	-08BS-2 I0	-0080	-08B-2 I0	-6084	-08APBS-2 I0	8		
-9067	-06BGS2-2 I0	-0068	-06BGS-2 I0	-0062	-06BS-2 I0	-0060	-06B-2 I0	-6064	-06APBS-2 I0	6		
▼ -9047	▼ -04BGS2-2 I0	▼ -0048	▼ -04BGS-2 I0	▼ -0042	▼ -04BS-2 I0	▼ -0040	▼ -04B-2 I0	▼ -6044	▼ -04APBS-2 I0	4		
39-30-9027	5566-02BGS2-2 I0	39-31-0028	5566-02BGS-2 I0	39-31-0022	5566-02BS-2 I0	39-31-0020	5566-02B-2 I0	39-30-6024	5566-02APBS-2 I0	2		
EDP NO.	ENG. NO.	EDP NO.	ENG. NO.	EDP NO.	ENG. NO.	EDP NO.	ENG. NO.	EDP NO.	ENG. NO.	EDP NO.	ENG. NO.	CKT. SIZE
5566-NBGS2-2 I0		5566-NBGS-2 I0		5566-NBS-2 I0		5566-NB-2 I0		5566-NAPBS-2 I0				
39-30-9246	5566-24BGS2	39-31-0247	5566-24BGS	39-31-0241	5566-24BS	39-29-3246	5566-24B	39-30-6243	5566-24APBS	24		
▲ -9226	▲ -22BGS2	▲ -0227	▲ -22BGS	▲ -0221	▲ -22BS	▲ -3226	▲ -22B	▲ -6223	▲ -22APBS	22		
-9206	-20BGS2	-0207	-20BGS	-0201	-20BS	-3206	-20B	-6203	-20APBS	20		
-9186	-18BGS2	-0187	-18BGS	-0181	-18BS	-3186	-18B	-6183	-18APBS	18		
-9166	-16BGS2		-16BGS	-0161	-16BS	-3166	-16B	-6163	-16APBS	16		
-9146	-14BGS2	-0147	-14BGS	-0141	-14BS	-3146	-14B	-6143	-14APBS	14		
-9126	-12BGS2	-0127	-12BGS	-0121	-12BS	-3126	-12B	-6123	-12APBS	12		
-9106	-10BGS2	-0107	-10BGS	-0101	-10BS	-3106	-10B	-6103	-10APBS	10		
-9086	-08BGS2	-0087	-08BGS	-0081	-08BS	-3086	-08B	-6083	-08APBS	8		
-9066	-06BGS2	-0067	-06BGS	-0061	-06BS	-3066	-06B	-6063	-06APBS	6		
▼ -9046	▼ -04BGS2	▼ -0047	▼ -04BGS	▼ -0041	▼ -04BS	▼ -3046	▼ -04B	▼ -6043	▼ -04APBS	4		
39-30-9026	5566-02BGS2	39-31-0027	5566-02BGS	39-31-0021	5566-02BS	39-29-3026	5566-02B	39-30-6023	5566-02APBS	2		
EDP NO.	ENG. NO.	EDP NO.	ENG. NO.	EDP NO.	ENG. NO.	EDP NO.	ENG. NO.	EDP NO.	ENG. NO.	EDP NO.	ENG. NO.	CKT. SIZE
5566-NBGS2		5566-NBGS		5566-NBS		5566-NB		5566-NAPBS				
39-31-0245	5566-24BPBS	39-31-0243	5566-24BPB	39-31-0246	5566-24BPBS-2 I0	39-31-0244	5566-24BPB-2 I0	24				
▲ -0225	▲ -22BPBS	▲ -0223	▲ -22BPB	▲ -0226	▲ -22BPBS-2 I0	▲ -0224	▲ -22BPB-2 I0	22				
-0205	-20BPBS	-0203	-20BPB	-0206	-20BPBS-2 I0	-0204	-20BPB-2 I0	20				
-0185	-18BPBS	-0183	-18BPB	-0186	-18BPBS-2 I0	-0184	-18BPB-2 I0	18				
-0165	-16BPBS	-0163	-16BPB	-0166	-16BPBS-2 I0	-0164	-16BPB-2 I0	16				
-0145	-14BPBS	-0143	-14BPB	-0146	-14BPBS-2 I0	-0144	-14BPB-2 I0	14				
-0125	-12BPBS	-0123	-12BPB	-0126	-12BPBS-2 I0	-0124	-12BPB-2 I0	12				
-0105	-10BPBS	-0103	-10BPB	-0106	-10BPBS-2 I0	-0104	-10BPB-2 I0	10				
-0085	-08BPBS	-0083	-08BPB	-0086	-08BPBS-2 I0	-0084	-08BPB-2 I0	8				
-0065	-06BPBS	-0063	-06BPB	-0066	-06BPBS-2 I0	-0064	-06BPB-2 I0	6				
▼ -0045	▼ -04BPBS	▼ -0043	▼ -04BPB	▼ -0046	▼ -04BPBS-2 I0	▼ -0044	▼ -04BPB-2 I0	4				
39-31-0025	5566-02BPBS	39-31-0023	5566-02BPB	39-31-0026	5566-02BPBS-2 I0	39-31-0024	5566-02BPB-2 I0	2				
EDP NO.	ENG. NO.	EDP NO.	ENG. NO.	EDP NO.	ENG. NO.	EDP NO.	ENG. NO.	EDP NO.	ENG. NO.	EDP NO.	ENG. NO.	CKT. SIZE
5566-NBPBS		5566-NBPB		5566-NBPBS-2 I0		5566-NBPB-2 I0						

PARTS WITH DRAIN HOLES

SEE SHEET 1 EC NO: UCP2014-212 DRAWING NO: 2013/11/13 CHKD: J.BELL APPR: FSMITH 2013/11/13 2013/11/13	QUALITY SYMBOLS ▽=0 ▽=0 ▽=0	GENERAL TOLERANCES (UNLESS SPECIFIED)		DIMENSION STYLE IN/MM		SCALE 1:1	DESIGN UNITS METRIC	THIRD ANGLE PROJECTION			
		4 PLACES ± .13 ± .010 3 PLACES ± .13 ± .010 2 PLACES ± .13 ± .010 1 PLACE ± .25 ± .010		DRAWN BY DATE H.HIRAMOTO '89/04/03		TITLE MINI FIT JR VERTICAL HEADER ASSEMBLIES WITHOUT PEGS		MOLEX MOLEX INCORPORATED			
		ANGULAR ± 3°		CHECKED BY DATE M.FUKUSHIMA '94/04/20		APPROVED BY DATE FSMITH 2012/05/04		MATERIAL NO. SEE TABLE		DOCUMENT NO. SD-5566-002	
		DRAFT WHERE APPLICABLE MUST REMAIN WITHIN DIMENSIONS		SIZE C		THIS DRAWING CONTAINS INFORMATION THAT IS PROPRIETARY TO MOLEX INCORPORATED AND SHOULD NOT BE USED WITHOUT WRITTEN PERMISSION		SHEET NO. 3 OF 5			

COLORED PART NUMBERS

EDP. NO.	ENG. NO.	EDP. NO.	ENG. NO.	EDP. NO.	ENG. NO.	EDP. NO.	ENG. NO.	EDP. NO.	ENG. NO.	CKT. SIZE		
										24		
										22		
										20		
46999-0085										18		
										16		
										14		
										12		
								46999-0087	5566-10AS-V	10		
										8		
										6		
										4		
										2		
										24		
								39-35-0248	5566-24A-400	24		
								39-35-0228	▲ -22A-400	22		
								39-35-0208	-20A-400	20		
								39-35-0188	-18A-400	18		
						39-33-3169	5566-16A-210-BU	39-35-0168	-16A-400	16		
								39-35-0148	-14A-400	14		
								39-35-0128	-12A-400	12		
				39-33-4100	5566-10A-210-RE	39-33-3109	5566-10A-210-BU	39-33-0108	-10A-400	10		
46999-0091	5566-08AS-GRE							39-35-0088	-08A-400	8		
								39-35-0068	-06A-400	6		
				39-33-4040	5566-04A-210-RE	39-33-3049	5566-04A-210-BU	39-35-0048	▼ -04A-400	4		
50-36-2485	5566-02AS-GRE	39-34-5023	5566-02A-210-YE	39-33-4020	5566-02A-210-RE	39-33-3029	5566-02A-210-BU	39-35-0028	5566-02A-400	2		
	EDP. NO.		ENG. NO.		EDP. NO.		ENG. NO.		EDP. NO.		ENG. NO.	CKT. SIZE
	5566-NAS-GRE		5566-NA-210-YE		5566-NA-210-RE		5566-NA-210-BU		5566-NA-400			24
												22
												20
												18
				39-33-3166	5566-16A-RE	39-33-3164	5566-16A-BU					16
39-33-3145	5566-14A-GR							39-33-3143	5566-14A-BL			14
				39-33-3126	5566-12A-RE	39-33-3124	5566-12A-BU					12
				39-33-3106	5566-10A-RE	39-33-3104	5566-10A-BU					10
		39-33-3087	5566-08A-YE	39-33-3086	5566-08A-RE	39-33-3084	5566-08A-BU	39-33-3083	5566-08A-BL			8
		39-33-3067	5566-06A-YE	39-33-3066	5566-06A-RE	39-33-3064	5566-06A-BU	39-33-3063	5566-06A-BL			6
				39-33-3046	5566-04A-RE	39-33-3044	5566-04A-BU	39-33-3043	5566-04A-BL			4
		39-33-3027	5566-02A-YE	39-33-3026	5566-02A-RE	39-33-3024	5566-02A-BU	39-33-3023	5566-02A-BL			2
	EDP. NO.		ENG. NO.		EDP. NO.		ENG. NO.		EDP. NO.		ENG. NO.	CKT. SIZE
	5566-NA-GR		5566-NA-YE		5566-NA-RE		5566-NA-BU		5566-NA-BL			24

PARTS WITHOUT DRAIN HOLES

SEE SHEET 1 EC NO: UCP2014-212 DRAWN: NGUYEN 2013/11/13 CHKD: J.BELL 2013/11/13 APPR: F.SMITH 2013/11/27 REV L7	QUALITY SYMBOLS	GENERAL TOLERANCES (UNLESS SPECIFIED)	DIMENSION STYLE	SCALE	DESIGN UNITS	THIRD ANGLE PROJECTION
	▽=0	mm INCH	IN/MM	1:1	METRIC	
	▽=0	4 PLACES ± --- ± ---	DRAWN BY DATE	TITLE		
	▽=0	3 PLACES ± --- ± .005	H.HIRAMOTO '89/04/03	MINI FIT JR VERTICAL HEADER ASSEMBLIES WITHOUT PEGS		
	2 PLACES ± .13 ± .010	CHECKED BY DATE	M.OLEX INCORPORATED			
	1 PLACE ± .25 ± ---	M.FUKUSHIMA '94/04/20	SD-5566-002			
	ANGULAR ± 3 °	APPROVED BY DATE	SHEET NO. 4 OF 5			
		F.SMITH 2012/05/04	THIS DRAWING CONTAINS INFORMATION THAT IS PROPRIETARY TO MOLEX INCORPORATED AND SHOULD NOT BE USED WITHOUT WRITTEN PERMISSION			
		MATERIAL NO.	DOCUMENT NO.			
		SEE TABLE				

TRAY PACKED PART NUMBERS

PARTS WITHOUT DRAIN HOLES					39-53-9249	5566-24A-210-TA	39-53-9248	5566-24A-TA	24	
						↑ -22A-210-TA	↑ -9228	↑ -22A-TA	22	
								↑ -20A-TA	20	
			39-34-1180	5566-18A-210-TR				↑ -18A-TA	18	
								↑ -16A-TA	16	
								↑ -14A-TA	14	
								↑ -12A-TA	12	
								↑ -10A-TA	10	
								↑ -08A-TA	8	
	46999-0630	5566-06AGS2-BL-TA						↑ -06A-TA	6	
46999-0629	5566-04AGS2-BL-TA						↓ -04A-TA	4		
						5566-02A-210-TA	39-53-9028	5566-02A-TA	2	
EDP NO.	ENG. NO.	EDP NO.	ENG. NO.	EDP NO.	ENG. NO.	EDP NO.	ENG. NO.	EDP NO.	ENG. NO.	CKT. SIZE
5566-NAGS2-BL-TA		5566-NA-210-TR		5566-NA-210-TA		5566-NA-TA				

SEE SHEET 1 EC NO: UCP2014-212 DRAWN: NGUYEN 2013/11/13 CHKD: BELL 2013/11/13 APPR: FSMITH 2013/11/27	L7	QUALITY SYMBOLS	GENERAL TOLERANCES (UNLESS SPECIFIED)		DIMENSION STYLE		SCALE	DESIGN UNITS	THIRD ANGLE PROJECTION	
		▽=0	mm	INCH	IN/MM		1:1	METRIC	☉	
		▽=0	4 PLACES ± .005	± .005	DRAWN BY	DATE	TITLE			
		▽=0	3 PLACES ± .010	± .010	H.HIRAMOTO	'89/04/03	MINI FIT JR VERTICAL HEADER ASSEMBLIES WITHOUT PEGS			
		▽=0	2 PLACES ± .13	± .010	M.FUKUSHIMA	'94/04/20	MOLEX INCORPORATED			
		1 PLACE ± .25	± .005	APPROVED BY	DATE	MATERIAL NO.		DOCUMENT NO.	SHEET NO.	
			ANGULAR ± 3°	FSMITH	2012/05/04	SEE TABLE		SD-5566-002	5 OF 5	
DRAFT WHERE APPLICABLE MUST REMAIN WITHIN DIMENSIONS			SIZE		THIS DRAWING CONTAINS INFORMATION THAT IS PROPRIETARY TO MOLEX INCORPORATED AND SHOULD NOT BE USED WITHOUT WRITTEN PERMISSION					