

10 9 8 7 6 5 4 3 2 1

NOTES :  
 1. MATERIAL:-  
 - PIN:- (0.65)/.0255 SQ. BRASS WIRE.  
 - HOUSING:- 15% GLASS FILLED POLYESTER  
 - UL 94 V-0 COLOUR BLACK

2. FOR PLATING VERSIONS AND VOID VERSIONS  
 SEE SHEET 2.

3. MEASUREMENT POINT FOR MINIMUM PLATING THICKNESS.

4. FOR PRODUCT SPEC SEE PS-99020-0001

5. RECOMMENDED PCB THICKNESS: 1.60mm

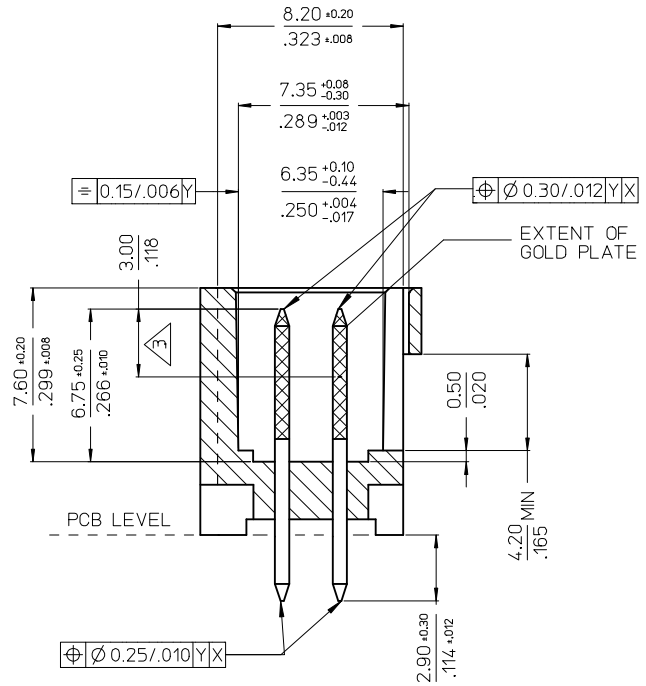
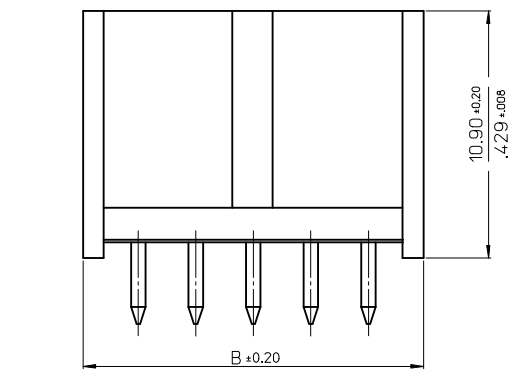
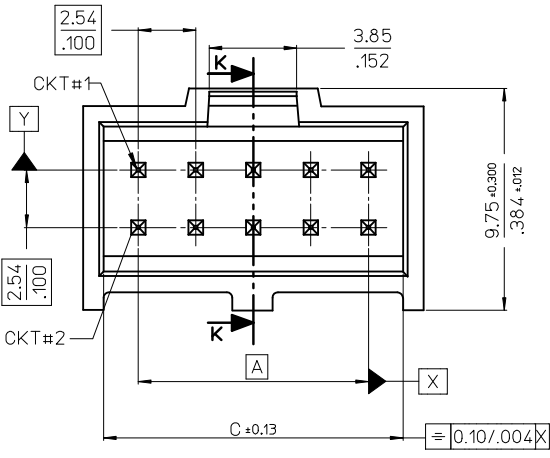

SECTION K-K

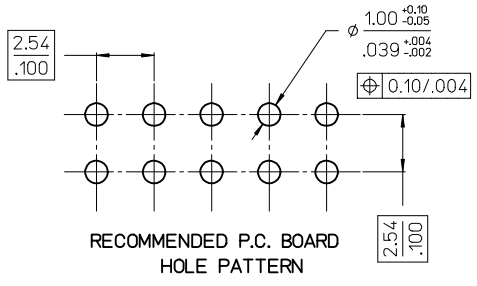

CKT	DIM A	DIM B	DIM C
6	(5.08)/ .200	(9.96)/ .392	(8.12)/ .320
8	(7.62)/ .300	(12.50)/ .492	(10.66)/ .420
10	(10.16)/ .400	(15.04)/ .592	(13.20)/ .520
12	(12.70)/ .500	(17.58)/ .692	(15.74)/ .620
14	(15.24)/ .600	(20.12)/ .792	(18.28)/ .720
16	(17.78)/ .700	(22.66)/ .892	(20.82)/ .820
18	(20.32)/ .800	(25.20)/ .992	(23.36)/ .920
20	(22.86)/ .900	(27.74)/ 1.092	(25.90)/ 1.020
22	(25.40)/ 1.000	(30.28)/ 1.192	(28.44)/ 1.120
24	(27.94)/ 1.100	(32.82)/ 1.292	(30.98)/ 1.220
26	(30.48)/ 1.200	(35.36)/ 1.392	(33.52)/ 1.320
28	(33.02)/ 1.300	(37.90)/ 1.492	(36.06)/ 1.420
30	(35.56)/ 1.400	(40.44)/ 1.592	(38.60)/ 1.520
32	(38.10)/ 1.500	(42.98)/ 1.692	(41.15)/ 1.620
34	(40.64)/ 1.600	(45.52)/ 1.792	(43.68)/ 1.720
36	(43.18)/ 1.700	(48.06)/ 1.892	(46.22)/ 1.820
38	(45.72)/ 1.800	(50.60)/ 1.992	(48.76)/ 1.920
40	(48.26)/ 1.900	(53.14)/ 2.092	(51.30)/ 2.020
42	(50.80)/ 2.000	(55.68)/ 2.192	(53.84)/ 2.120
44	(53.34)/ 2.100	(58.22)/ 2.292	(56.38)/ 2.220
46	(55.88)/ 2.200	(60.76)/ 2.392	(58.92)/ 2.320
48	(58.42)/ 2.300	(63.30)/ 2.492	(61.46)/ 2.420
50	(60.96)/ 2.400	(65.84)/ 2.592	(64.00)/ 2.520
52	(63.50)/ 2.500	(68.38)/ 2.692	(66.54)/ 2.620
54	(66.04)/ 2.600	(70.92)/ 2.792	(69.08)/ 2.720
56	(68.58)/ 2.700	(73.46)/ 2.892	(71.62)/ 2.820
58	(71.12)/ 2.800	(76.00)/ 2.992	(74.16)/ 2.920
60	(73.66)/ 2.900	(78.54)/ 3.092	(76.70)/ 3.020
62	(76.20)/ 3.000	(81.08)/ 3.192	(79.24)/ 3.120
64	(78.74)/ 3.100	(83.62)/ 3.292	(81.78)/ 3.220
66	(81.28)/ 3.200	(86.16)/ 3.392	(84.32)/ 3.320
68	(83.82)/ 3.300	(88.70)/ 3.492	(86.86)/ 3.420

ADD DATUMS  
 EC NO: S2015-0152  
 DRWN:ATSEE 2014/08/18  
 CHKD:FANNYWONG 2014/08/18  
 APPR:LBLEE 2014/08/19  
 CA2

QUALITY SYMBOLS  
 $F_A=0$   
 $F_E=0$   
 $F_B=0$

GENERAL TOLERANCES (UNLESS SPECIFIED)

	mm	INCH
4 PLACES	± ---	± ---
3 PLACES	± ---	± .004
2 PLACES	± 0.10	± ---
1 PLACE	± ---	± ---

ANGULAR ±1/2°

DRAFT WHERE APPLICABLE  
 MUST REMAIN  
 WITHIN DIMENSIONS

DIMENSION STYLE  
 MM/IN

SCALE  
 NTS

DESIGN UNITS  
 INCH

THIRD ANGLE PROJECTION

DRAWN BY: KS  
 DATE: 1988/08/23

CHECKED BY: ATSEE  
 DATE: 2010/02/11

APPROVED BY: MLONG  
 DATE: 2010/02/19

MATERIAL NO.  
 SEE TABLE

TITLE  
**C-GRID III  
 DUAL ROW STRAIGHT  
 SHROUDED HEADER**

**MOLEX INCORPORATED**

DOCUMENT NO.  
 SDA-90130

SHEET NO.  
 1 OF 4

THIS DRAWING CONTAINS INFORMATION THAT IS PROPRIETARY TO MOLEX INCORPORATED AND SHOULD NOT BE USED WITHOUT WRITTEN PERMISSION

9 8 7 6 5 4 3 2 1

**VERSION FULLY LOADED**

NOTES :  
 1. FOR ASSEMBLY, SEE SHEET 1.  
 2. REFER TO LEGEND FOR PLATING OPTIONS.

NO OF CKTS	HSG CKT SIZE	PART NUMBER			
		PLATING TYPE A	PLATING TYPE E	PLATING TYPE F	PLATING TYPE G
6	6	90130-X106	90130-X206	90130-X306	90130-X406
8	8	X108	X208	X308	X408
10	10	X110	X210	X310	X410
12	12	X112	X212	X312	X412
14	14	X114	X214	X314	X414
16	16	X116	X216	X316	X416
18	18	X118	X218	X318	X418
20	20	X120	X220	X320	X420
22	22	X122	X222	X322	X422
24	24	X124	X224	X324	X424
26	26	X126	X226	X326	X426
28	28	X128	X228	X328	X428
30	30	X130	X230	X330	X430
32	32	X132	X232	X332	X432
34	34	X134	X234	X334	X434
36	36	X136	X236	X336	X436
38	38	X138	X238	X338	X438
40	40	X140	X240	X340	X440
42	42	X142	X242	X342	X442
44	44	X144	X244	X344	X444
46	46	X146	X246	X346	X446
48	48	X148	X248	X348	X448
50	50	X150	X250	X350	X450
52	52	X152	X252	X352	X452
54	54	X154	X254	X354	X454
56	56	X156	X256	X356	X456
58	58	X158	X258	X358	X458
60	60	X160	X260	X360	X460
62	62	X162	X262	X362	X462
64	64	X164	X264	X364	X464
66	66	X166	X266	X366	X466
68	68	90130-X168	90130-X268	90130-X368	90130-X468

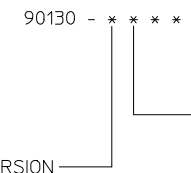

STYLE: - 1. STRAIGHT PIN VERSION  
 8. VERSION WITH VOIDS

- 1 - TYPE A:  
3.04µm MIN. TIN OVER 1.27µm - 2.54µm NICKEL.
- 2 - TYPE E:  
0.38µm MIN. GOLD IN SELECTED AREA & 3.04µm MIN. TIN IN SELECTED AREA OVER 1.3µm MIN. NICKEL OVERALL.
- 3 - TYPE F:  
0.76µm MIN. GOLD IN SELECTED AREA. & 3.04µm MIN. TIN IN SELECTED AREA OVER 1.3µm MIN. NICKEL OVERALL.
- 4 - TYPE G:  
0.05 -0.10µm GOLD FLASH IN SELECTED AREA & 3.04µm MIN. TIN IN SELECTED AREA OVER 1.3µm MIN. NICKEL OVERALL.

**VOIDED OPTIONS**

NO OF CKTS	HSG CKT SIZE	VOIDED PART NUMBER	VOID POSITION	PLATING TYPE
9	10	90130-8190	3	A
9	10	90130-8309	2	F
9	10	90130-8311	1	F
11	12	90130-8212	12	E
11	12	90130-8213	2	E
11	12	90130-8313	2	F
11	12	90130-8191	3	A

ADD DATUMS EC NO: S2015-0152 DRW:ATSEE CHKD:FANNYONG APPR:LBLEE CA2	2014/08/18 2014/08/18 2014/08/19	QUALITY SYMBOLS $F_A=0$ $F_E=0$ $F_F=0$	GENERAL TOLERANCES (UNLESS SPECIFIED) mm    INCH 4 PLACES ± --- ± --- 3 PLACES ± --- ± .004 2 PLACES ± 0.10 ± --- 1 PLACE ± --- ± --- ANGULAR ± 1/2°	DIMENSION STYLE MM/IN DRAWN BY: KS    DATE: 1988/08/23 CHECKED BY: ATSEE    DATE: 2010/02/11 APPROVED BY: MLONG    DATE: 2010/02/19	SCALE NTS	DESIGN UNITS INCH	THIRD ANGLE PROJECTION	TITLE C-GRID III DUAL ROW STRAIGHT SHROUDED HEADER	MOLEX INCORPORATED	MATERIAL NO. SEE TABLE	DOCUMENT NO. SDA-90130	SHEET NO. 2 OF 4
	DRAFT WHERE APPLICABLE MUST REMAIN WITHIN DIMENSIONS											
	THIS DRAWING CONTAINS INFORMATION THAT IS PROPRIETARY TO MOLEX INCORPORATED AND SHOULD NOT BE USED WITHOUT WRITTEN PERMISSION											
	SIZE A3											

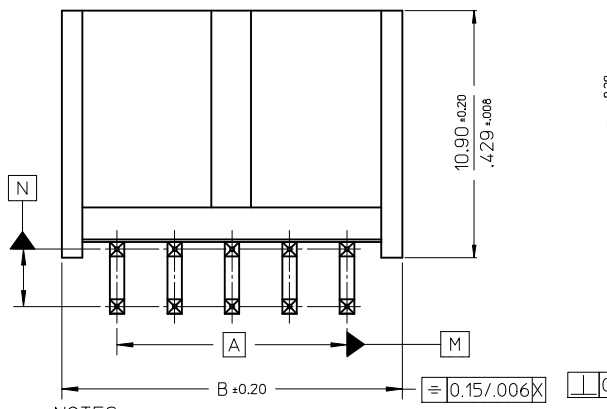
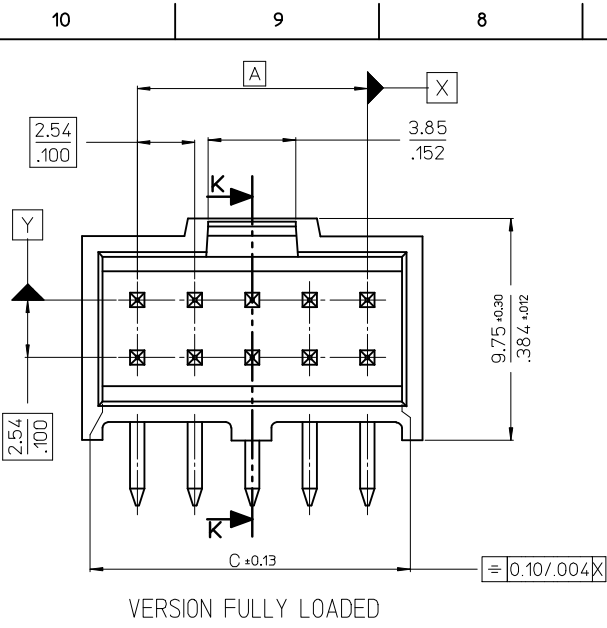

- NOTES :
- MATERIAL:-  
 - PIN:- (0.65)/.0255 SQ. BRASS WIRE.  
 - HOUSING:- 15% GLASS FILLED POLYESTER  
 - UL 94 V-0 COLOUR BLACK
  - FOR PLATING VERSIONS AND VOID VERSIONS  
 SEE SHEET 2.
  - MEASUREMENT POINT FOR MINIMUM PLATING THICKNESS.
  - FOR PRODUCT SPEC SEE PS-99020-0001
  - RECOMMENDED PCB THICKNESS: 1.60mm

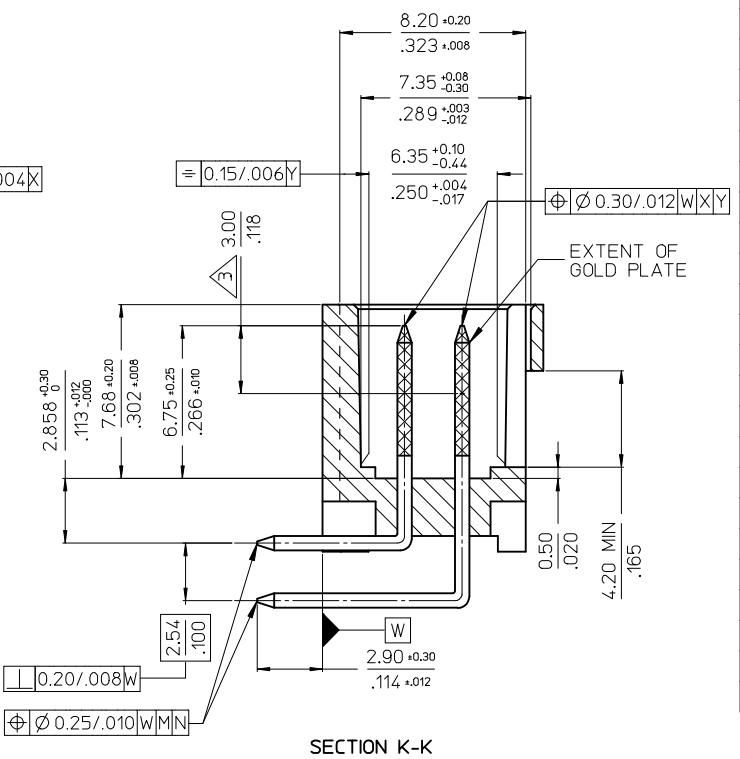
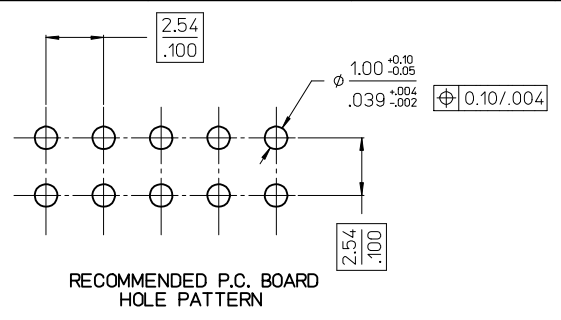

CKT	DIM A	DIM B	DIM C
6	(5.08)/.200	(9.96)/.392	(8.12)/.320
8	(7.62)/.300	(12.50)/.492	(10.66)/.420
10	(10.16)/.400	(15.04)/.592	(13.20)/.520
12	(12.70)/.500	(17.58)/.692	(15.74)/.620
14	(15.24)/.600	(20.12)/.792	(18.28)/.720
16	(17.78)/.700	(22.66)/.892	(20.82)/.820
18	(20.32)/.800	(25.20)/.992	(23.36)/.920
20	(22.86)/.900	(27.74)/.1092	(25.90)/.1020
22	(25.40)/.1000	(30.28)/.1192	(28.44)/.1120
24	(27.94)/.1100	(32.82)/.1292	(30.98)/.1220
26	(30.48)/.1200	(35.36)/.1392	(33.52)/.1320
28	(33.02)/.1300	(37.90)/.1492	(36.06)/.1420
30	(35.56)/.1400	(40.44)/.1592	(38.60)/.1520
32	(38.10)/.1500	(42.98)/.1692	(41.15)/.1620
34	(40.64)/.1600	(45.52)/.1792	(43.68)/.1720
36	(43.18)/.1700	(48.06)/.1892	(46.22)/.1820
38	(45.72)/.1800	(50.60)/.1992	(48.76)/.1920
40	(48.26)/.1900	(53.14)/.2092	(51.30)/.2020
42	(50.80)/.2000	(55.68)/.2192	(53.84)/.2120
44	(53.34)/.2100	(58.22)/.2292	(56.38)/.2220
46	(55.88)/.2200	(60.76)/.2392	(58.92)/.2320
48	(58.42)/.2300	(63.30)/.2492	(61.46)/.2420
50	(60.96)/.2400	(65.84)/.2592	(64.00)/.2520
52	(63.50)/.2500	(68.38)/.2692	(66.54)/.2620
54	(66.04)/.2600	(70.92)/.2792	(69.08)/.2720
56	(68.58)/.2700	(73.46)/.2892	(71.62)/.2820
58	(71.12)/.2800	(76.00)/.2992	(74.16)/.2920
60	(73.66)/.2900	(78.54)/.3092	(76.70)/.3020
62	(76.20)/.3000	(81.08)/.3192	(79.24)/.3120
64	(78.74)/.3100	(83.62)/.3292	(81.78)/.3220
66	(81.28)/.3200	(86.16)/.3392	(84.32)/.3320
68	(83.82)/.3300	(88.70)/.3492	(86.86)/.3420

<b>ADD DATUMS</b> EC NO: S2015-0152 DRW: NATSEE CHKD: FANNY WONG APPR: LBLEE	<b>QUALITY SYMBOLS</b> $F_A = 0$ $F_C = 0$ $F_P = 0$	<b>GENERAL TOLERANCES (UNLESS SPECIFIED)</b>		<b>DIMENSION STYLE</b> MM/IN		<b>SCALE</b> NTS	<b>DESIGN UNITS</b> INCH	THIRD ANGLE PROJECTION
		4 PLACES	± ---	± ---	DRAWN BY	DATE	TITLE	
		3 PLACES	± ---	± .004	CHECKED BY	DATE	<b>C-GRID III          DUAL ROW STRAIGHT          SHROUDED HEADER</b>	
		2 PLACES	± 0.10	± ---	APPROVED BY	DATE		
1 PLACE ± --- ± ---		ANGULAR ± 1/2°	MLONG	2010/02/19	<b>MOLEX INCORPORATED</b>			
DRAFT WHERE APPLICABLE MUST REMAIN WITHIN DIMENSIONS			MATERIAL NO.	DOCUMENT NO.				
SEE TABLE			SDA-90130			SHEET NO. 3 OF 4		

**VERSION FULLY LOADED**

NO OF CKTS	HSG CKT SIZE	PART NUMBER			
		PLATING TYPE A	PLATING TYPE E	PLATING TYPE F	PLATING TYPE G
6	6	90130-X106	90130-X206	90130-X306	90130-X406
8	8	X108	X208	X308	X408
10	10	X110	X210	X310	X410
12	12	X112	X212	X312	X412
14	14	X114	X214	X314	X414
16	16	X116	X216	X316	X416
18	18	X118	X218	X318	X418
20	20	X120	X220	X320	X420
22	22	X122	X222	X322	X422
24	24	X124	X224	X324	X424
26	26	X126	X226	X326	X426
28	28	X128	X228	X328	X428
30	30	X130	X230	X330	X430
32	32	X132	X232	X332	X432
34	34	X134	X234	X334	X434
36	36	X136	X236	X336	X436
38	38	X138	X238	X338	X438
40	40	X140	X240	X340	X440
42	42	X142	X242	X342	X442
44	44	X144	X244	X344	X444
46	46	X146	X246	X346	X446
48	48	X148	X248	X348	X448
50	50	X150	X250	X350	X450
52	52	X152	X252	X352	X452
54	54	X154	X254	X354	X454
56	56	X156	X256	X356	X456
58	58	X158	X258	X358	X458
60	60	X160	X260	X360	X460
62	62	X162	X262	X362	X462
64	64	X164	X264	X364	X464
66	66	X166	X266	X366	X466
68	68	90130-X168	90130-X268	90130-X368	90130-X468

NOTES :  
 1. FOR ASSEMBLY, SEE SHEET 1.  
 2. REFER TO LEGEND FOR PLATING OPTIONS

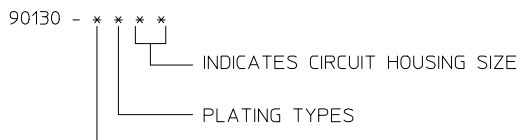

- 1 - TYPE A:  
3.0µm MIN. TIN OVER 1.27µm - 2.54µm NICKEL.
- 2 - TYPE E:  
0.38µm MIN. GOLD IN SELECTED AREA & 3.0µm MIN. TIN IN SELECTED AREA OVER 1.3µm MIN. NICKEL OVERALL.
- 3 - TYPE F:  
0.76µm MIN. GOLD IN SELECTED AREA & 3.0µm MIN. TIN IN SELECTED AREA OVER 1.3µm MIN. NICKEL OVERALL.
- 4 - TYPE G  
0.05-0.10µm GOLD FLASH IN SELECTED AREA & 3.0µm MIN. TIN IN SELECTED AREA OVER 1.3µm MIN. NICKEL OVERALL.

ADD DATUMS EC NO: S2015-0152 DRWN:ATSEE CHKD:FANNY WONG APPR: LBLEE 2014/08/18 2014/08/18 2014/08/19	QUALITY SYMBOLS	GENERAL TOLERANCES (UNLESS SPECIFIED)	DIMENSION STYLE	SCALE	DESIGN UNITS	THIRD ANGLE PROJECTION
	$\nabla_A = 0$ $\nabla_E = 0$ $\nabla_F = 0$	mm INCH	MM/IN	NTS	INCH	
	4 PLACES ± --- ± --- 3 PLACES ± --- ± .004 2 PLACES ± 0.10 ± --- 1 PLACE ± --- ± --- ANGULAR ± 1/2°	DRAWN BY: KS CHECKED BY: ATSEE APPROVED BY: MLONG DATE: 1988/08/23 DATE: 2010/02/11 DATE: 2010/02/19	TITLE	C-GRID III DUAL ROW STRAIGHT SHROUDED HEADER MOLEX INCORPORATED		
	DRAFT WHERE APPLICABLE MUST REMAIN WITHIN DIMENSIONS	SEE TABLE THIS DRAWING CONTAINS INFORMATION THAT IS PROPRIETARY TO MOLEX INCORPORATED AND SHOULD NOT BE USED WITHOUT WRITTEN PERMISSION	MATERIAL NO. SDA-90130	DOCUMENT NO. SDA-90130	SHEET NO. 4 OF 4	