

NOTES:

- TO BE USED WITH #22-#28 AWG STRANDED WIRE WITH (1.35)/.053 DIA. MAX. INSULATION.
- STANDARD PACKAGING FOR GROUPED HOUSING ASSEMBLIES PER PK-70873-0215.
- TERMINALS ARE SHOWN PRE-LOADED INTO HOUSING AND LOCKED INTO THE FIRST ROW OF WINDOWS.
- ALL DIMENSIONS ARE REFERENCE ONLY.
- SEE DWG. SD-70066-**** FOR OPTIONAL HOUSING DETAILS.
- REFER TO PRODUCT SPECIFICATION PS-70400.
- FOR ACCOUNTING PURPOSES ONLY, ONE EDP ORDER NUMBER REPRESENTS ONLY ONE HOUSING OF ANY GIVEN CHAINED COMBINATION OF CKT. SIZES.

PLATING CODES:

164 - .000150 MIN. TIN/LEAD PLATE OVER NICKEL PLATE.

571 - .000015 MIN. GOLD PLATE IN SELECTED AREA, .000075 MIN. TIN/LEAD PLATE IN SELECTED AREA, OVER NICKEL PLATE OVERALL.

574 - .000030 MIN. GOLD PLATE IN SELECTED AREA, .000075 MIN. TIN/LEAD PLATE IN SELECTED AREA, OVER NICKEL PLATE OVERALL.

P164 - .000150 MIN. TIN/LEAD PLATE OVER MIN. NICKEL PLATE. (PRE-PLATE)

PLATING CODE (STRIPE ON CARRIER STRIP)

PLATING	COLOR
164	NONE
571	YELLOW
574	RED
P164	NONE

I.D. SLOT/WIRE GAUGE CHART

SLOT I.D.	SLOT SIZE	WIRE GAUGE
A	.015 ±.002/(0.38 ±0.05)	24 AWG - STRANDED
B	.011 ±.002/(0.28 ±0.05)	26 AWG - STRANDED
C	.0075 ±.002/(0.19 ±0.05)	28 AWG - STRANDED
D	.019 ±.002/(0.48 ±0.05)	22 AWG - STRANDED

E9	ADD -7713,7723 ECR UDT2000-1190 KMS 05/30/2000	E6	ADD CARRIER CHAMF ECN #UDT1998-0280 05/20/98 LMGRATH
E8	SHT 4, ADD: P/N-0074 UDT 2000-0605 GIZOWSKI 12-29-99	E5	ADDED PARTS ECR #U7-0423 MCFARLAN 96-10-16
E7	REL-0071, 72, 73 UDT 1999-0371 SCHAFER 11-13-9	E4	ADDED ENG* -0063 ECR# U7-0283 MCFARLAN 96-9-17
LTR.	REVISIONS	LTR.	REVISIONS

DIMENSIONS SHOWN (METRIC) INCH
UNLESS OTHERWISE SPECIFIED
TOLERANCES: ANGULAR ± 1/2°

	INCH	METRIC
3 PLACE ±		
2 PLACE ±		
1 PLACE ±		

DRAFT WHERE APPLICABLE MUST REMAIN WITHIN DIMENSIONS

DRW: MGB CHK'D: MJM
APP'D: MJM SCALE: 4 : 1

▽ = 0 ▼ = 0 REVISE ONLY ON CAD SYSTEM

TITLE: ASSEMBLY, CONNECTOR BOX I.D. SINGLE ROW/.100 GRID GROUPED HOUSINGS

FORM: MOLEX INCORPORATED SHEET NO. DATE
L15LEJLL 60532 U.S.A. 1 OF 4 11/20/89

PART NO. DRWG. NO.
SEE CHART SDA-70977-****

FILE NAME: ST0977X1 THIS DRAWING CONTAINS INFORMATION THAT IS PROPRIETARY TO MOLEX INC. AND SHOULD NOT BE USED WITHOUT WRITTEN PERMISSION. DA C

ONE EDP NUMBER REPRESENTS ONE INDIVIDUAL HOUSING (SEE NOTE 6)

EDP NUMBER	ENG. NUMBER	DIM. "A" (MAX.)	DIM. "B" (MAX.)	OPTION	CIRCUIT SIZE	NUMBER OF HOUSINGS IN TOTAL ASSEMBLY	VOIDED CIRCUIT LOCATION	PLATING	WIRE SIZE
014-60-7522	A-70977-0051	1.599 (40.61)	.799 (20.29)	G	8	2	N/A	164	24 AWG
014-60-4035	A-70977-0052	.599 (15.21)	.299 (7.59)	A	3	2	N/A	574	26 AWG
014-60-7523	A-70977-0053	.599 (15.21)	.299 (7.59)	A	3	2	N/A	164	26 AWG
014-60-7122	A-70977-0054	1.999 (50.77)	.199 (5.05)	A	2	10	N/A	164	24 AWG
014-60-7045	A-70977-0055	1.599 (40.61)	.399 (10.13)	G	4	4	N/A	164	28 AWG
014-60-7533	A-70977-0056	2.399 (60.93)	.299 (7.59)	C	3	3	N/A	571	26 AWG
014-60-7035	A-70977-0057	1.999 (50.77)	.199 (5.05)	G	2	10	N/A	164	28 AWG
014-60-7543	A-70977-0058	1.999 (50.77)	.499 (12.67)	A	5	4	N/A	574	26 AWG
014-60-7553	A-70977-0059	.999 (25.37)	.199 (5.05)	G	2	5	N/A	571	24 AWG
014-60-7563	A-70977-0060	1.499 (38.07)	.299 (7.59)	G	3	5	N/A	571	24 AWG
014-60-7573	A-70977-0061	1.199 (30.45)	.399 (10.13)	A	4	3	2	571	26 AWG
014-60-7583	A-70977-0062	1.199 (30.45)	.399 (10.13)	G	4	3	N/A	164	24 AWG
014-60-7593	A-70977-0063	1.999 (50.77)	.399 (10.13)	A	4	5	N/A	571	26 AWG
014-60-7603	A-70977-0064	.799 (20.21)	.199 (5.05)	G	2	4	N/A	571	24 AWG
014-60-7613	A-70977-0065	1.199 (30.33)	.199 (5.05)	G	2	6	N/A	571	24 AWG
014-60-7623	A-70977-0066	1.999 (50.55)	.199 (5.05)	G	2	10	N/A	571	24 AWG
014-60-7633	A-70977-0067	.899 (22.78)	.299 (7.59)	G	3	3	N/A	571	24 AWG
014-60-7643	A-70977-0068	1.199 (30.38)	.299 (7.59)	G	3	4	N/A	571	24 AWG
014-60-7653	A-70977-0069	1.799 (45.57)	.299 (7.59)	G	3	6	N/A	571	24 AWG
014-60-7663	A-70977-0070	1.199 (30.33)	.199 (5.05)	G	2	6	N/A	164	24 AWG
014-60-7673	A-70977-0071	1.799 (45.57)	.299 (7.59)	D	3	6	N/A	571	24 AWG
014-60-7683	A-70977-0072	1.199 (30.38)	.299 (7.59)	D	3	4	N/A	571	24 AWG
014-60-7693	A-70977-0073	1.199 (30.33)	.199 (5.05)	D	2	6	N/A	571	24 AWG
014-60-7703	A-70977-0074	.599 (15.21)	.299 (7.59)	G	3	2	N/A	574	24 AWG
014-60-7713	A-70977-0075	2.999 (25.37)	.199 (5.05)	G	2	15	N/A	571	24 AWG
014-60-7723	A-70977-0076	2.999 (38.07)	.299 (7.59)	G	3	10	N/A	571	24 AWG

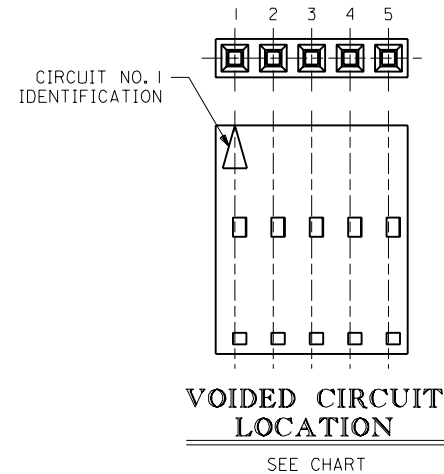

E5	SEE SHEET I
E4	SEE SHEET I
E3	SEE SHEET I
E2	SEE SHEET I
E1	SEE SHEET I
E	SEE SHEET I
D	SEE SHEET I
LTR.	REVISIONS

DIMENSIONS SHOWN (METRIC) INCH	
UNLESS OTHERWISE SPECIFIED TOLERANCES ANGULAR ± 1/2°	
3 PLACE ±	INCH METRIC
2 PLACE ±	±
1 PLACE ±	±
DRAFT WHERE APPLICABLE MUST REMAIN WITHIN DIMENSIONS	
DRWG. BY: AAB	CHK'D. BY: MJM
APP'D. BY: MJM	SCALE: :
LTR.	REVISIONS

= 0 = 0 = 0 **REVISE ONLY ON CAD SYSTEM**
TITLE
 ASSEMBLY, CONNECTOR BOX I.D.
 SINGLE ROW/.100 GRID
 GROUPED HOUSINGS
MOLEX INCORPORATED SHEET NO. DATE
 LISLE, ILL. 60532 U.S.A. 4 05/22/91
SEE CHART **SDA-70977-*******
 FILE NAME: S70977X4 THIS DRAWING CONTAINS INFORMATION THAT IS PROPRIETARY TO MOLEX INC. AND SHOULD NOT BE USED WITHOUT WRITTEN PERMISSION. DIV. SIZE: DA | C

70977